

I'm So Glad You Asked!



**Dr. Max D. Younce
Answers Your
Questions On The Bible**

Volume II

Copyright © 2010
ALL RIGHTS RESERVED

No portion of this publication may be reproduced, stored in any electronic system, or transmitted in any form or by any means, electronic, mechanical, photocopy, recording, or otherwise, without written permission from the author. Brief quotations may be used in literary reviews.

Unless otherwise indicated, all Scripture quotations are taken from the King James Translation of the Bible.

Library of Congress Control Number: 2010913162

ISBN-13: 978-0-9815225-9-3
First Printing: 2010

HERITAGE BAPTIST BIBLE CHURCH
P.O. Box 573
Walnut Grove, MN 56180
Dr. Max D. Younce, Pastor
Web: www.heritagebbc.com

Printed in the USA By
Morris Publishing
3212 E. Hwy. 30
Kearney, NE 68847
800-650-7888

Table of Contents

WHAT THIS BOOK IS ABOUT.....	8
Bible Questions & Answers.....	8
www.heritagebbc.com.....	8
I. LORDSHIP SALVATION.....	9
1. Must We Accept Jesus as Savior and Lord?	9
II. MARRIAGE & FAMILY.....	12
1. Should a Woman Take Her Husband's Name?	12
2. Do We Have to Hate Our Family to Serve the Lord?	13
3. When Does Life Begin?.....	14
4. Is An Unbelieving Spouse A Believer If He Marries a Believer?.....	16
<i>1 Corinthians 7:14</i>	16
5. What Does The Bible Say About Interracial Marriages?.....	17
6. What Does The Bible Say to Abused Wives?.....	18
7. Should a Protestant Marry a Roman Catholic?	20
III. MINISTRY.....	27
1. Does Divorce Disqualify a Man for the Pastorate? Case 1:	27
2. Does Divorce Disqualify a Man from the Pastorate? Case 2:.....	28
3. Can a Man Who Has Divorced and Remarried Be a Pastor? Case 3: .	30
IV. NOAH'S ARK.....	34
1. How Could Noah's Ark Hold All The Species of Animals?	34
2. Were There Rooms in the Ark?	35
3. What Period in History Did Noah Live?.....	36
4. How Long Did It Take Noah to Build the Ark?.....	37
V. OCCULT.....	40
1. Explain the "Light at the End of the Tunnel" & NDEs?	40
2. Knitting Shawls and a "Mother God!"	41
VI. PARABLES.....	46
1. What Does The Parable of the Laborers Mean?	46
<i>Matthew 20:1-16</i>	46
2. Why Was The Unprofitable Servant Cast Into Hell?.....	47
<i>Matthew 25:14-30 Vs. Ephesians 2:8,9</i>	47
VII. PREDESTINATION, FOREKNOWLEDGE, ELECTION. 48	48
1. Is the World's Condition God's Fault?	48
2. They Closed Their Own Eyes!.....	50
<i>Matthew 13:10-17, Mark 4:10-12; Luke 8:9-10; Isaiah 6:9-10</i>	50
3. Does God Give Us the Faith to Believe With?	51
4. Does God Predestinate Only Some to Be Saved?.....	55
<i>Matthew 20:16</i>	55
5. Please Define "Predestination" in Ephesians 1:5	57
6. Please Define "Predestination" in Ephesians 1:11,12?	59
7. What Is the Meaning of the Word "Predestination" In Romans 8:29? 61	

8.	When Did God Begin to Hate Esau, as in Romans 9:13?	63
9.	Did Christ Predestinate Some to Salvation & Not Others?.....	67
	<i>Romans 8:30</i>	67
10.	Who Hardened Pharaoh's Heart?	69
VIII.	PROPHECY	76
1.	Who Is The Rider on a White Horse?	76
	<i>Revelation 6:2</i>	76
2.	Did God Predict That We Would Have Television?.....	77
	<i>Daniel 12:4; Revelation 11:9</i>	77
3.	Is Gog & Magog Russia & Why Does She Attack Israel?.....	78
	<i>Ezekiel 38,39</i>	78
4.	Who Will Be Russia's Allies?	79
	<i>Ezekiel 38:5,6</i>	79
5.	When Will Russia Attack Israel?	81
6.	Why Will Russia Attack Israel?.....	82
	<i>Ezekiel 38:13; 19:1,2; 1 Kings 11:42,43</i>	82
7.	How Will God Destroy the Armies of Russia & Her Allies?	83
	<i>Ezekiel 38:18,21,22; Ezekiel 39:2;</i>	83
8.	When Will the Armies of Russia & Her Allies Be Destroyed?	85
	<i>Ezekiel 39:10,12</i>	85
9.	Will Children Go at the Rapture?	86
10.	Can I Be Saved After the Rapture?.....	87
11.	Will Backslidden Christians Go at the Rapture?.....	89
12.	When Will All Of Israel Be Saved?.....	90
	<i>Romans 11:26</i>	90
13.	Is This Present Earth Going to Be Renovated, or Annihilated?	92
	<i>Revelation 21:1</i>	92
14.	Is The Rapture Before, During; Or, After the Tribulation Period?	97
	1. The Post-Tribulation Rapture.....	97
	2. A Pre-Tribulation Rapture Is What The Bible Teaches.	98
	3. Spiritual & Carnal all Raptured At the Same Time.....	100
	4. The Rapture Is The Redemption of Our Body.	101
	5. Both Spiritual and Carnal Christians Go At The Rapture.	102
	6. No Such Thing As A Post-Tribulation Rapture	102
	7. Conclusion.....	104
15.	Please Give An Explanation of Daniel 9:24-27.	107
16.	An Outline of Future Prophecy.....	117
	"Blueprint For The Future"	117
17.	Who Are the "Two Witnesses" In Revelation 11?.....	119
18.	Who Are the Two Olive Trees of Zechariah Four?	142
	<i>Zechariah 4:1-14</i>	142
	I. Introduction – Preliminary view of Chapter Four.....	142
	II. "A Picture Is Worth a Thousand Words."	143

III. Visual Aids For Prophecy.....	144
5. The Future Prophecy, The Two Olive Trees.....	148
IX. PSALMS	152
1. What Are Some Guidelines for Study of the Psalms?	152
2. What Are the Meanings of the Psalm Titles?.....	153
3. How Can the Imprecatory Psalms Be Explained?	154
X. REINCARNATION	157
1. What Does The Bible Say About Reincarnation?.....	157
Who Is Behind Reincarnation?.....	162
What About Suicide As Influenced By Reincarnation?.....	164
Satan Is Behind It All!	165
XI. REPENTANCE.....	166
1. The "Case of The Pride-Filled Church"	166
<i>2 Corinthians 7:10</i>	166
XII. RESURRECTION.....	170
1. How Could Jonah Live After Being Swallowed By A Whale	170
2. Was Christ Before Pilate At the Sixth Hour; or On the Cross?	171
<i>John 19:14,15 Vs. Matthew 27:44,45</i>	171
3a. The Fallacy of "Good Friday" and "Easter Sunday"	172
Three Important Things To Remember:.....	173
The Resurrection Day:.....	173
3b. Diagram A. 72 Hours in the Grave to Fulfill Matthew 12:40	175
3c. Explanation of the Time Chart of the Events During the Trial and Conviction of Jesus: Diagram B	176
3d. Diagram B. A Time Chart of Events During the Week of Christ's Trial, Crucifixion, and Resurrection.	183
XIII. THE SABBATH.....	184
1. How Is The Sabbath Made For Man?	184
XIV. SALVATION.....	187
1. Can I Know, with Certainty, If I Am Going to Heaven?	187
2. Can a Saved Person Ever Be Lost?.....	188
3. Does Hebrews 10:26-30 Mean a Christian Can Go to Hell?	189
4. Please Explain the Rich Man and The Kingdom of God	190
<i>Matthew 19:24</i>	190
5. Why Does the Sin of Adam Make All Men Sinners?	192
<i>1 Timothy 2:14,15</i>	192
6. Is Baptism Required for Salvation?	193
<i>John 3:5</i>	193
7. Once Saved, Always Saved; Or Eternally Secure?	195
<i>2 Peter 2:21</i>	195
8. What Is The Fruit of Salvation? John 15:4	197
9. What Happens If We Die with Un-Confessed Sin?	198
10. Does Galatians 5:4 Teach That You Can Lose Your Salvation?	200

11. How Can I Witness to My Jewish Friends?	202
12. Does Titus 3:5 Teach Baptism For Salvation?.....	204
13. Does Doing Good to Your Fellow Man Get You to Heaven?	207
XV. SATAN & THE DEMONS	218
1. Was the Serpent In Eden a Literal Snake?	218
2. Why Did God Create the Devil?	219
3. Why Do the Devils Tremble When They Believe?	220
4. Can Satan Deceive Us With Visions and Dreams?.....	221
XVI. TONGUES, FAITH HEALING, SIGNS.....	223
1. What Are the Greater Works Spoken of in John 14:12?	223
2. What Was Paul's Thorn?.....	224
<i>2 Corinthians 12:7-9</i>	224
3. Is There Physical Healing in the Atonement?.....	225
<i>Isaiah 53:4</i>	225
4. Is Speaking In Tongues Proof of Salvation?.....	226
XVII. YOUNG EARTH, A FALSE DOCTRINE.....	229
1. The Fraudulent Young Earth Theory or Philosophy	229
<i>Where Did The Young Earth Philosophy Originate?</i>	229
2. Two Views of Creation.....	230
3. Creation Diagram One : The Gap Principle Illustrated.....	232
4. Genesis One, "Created" and "Made."	233
"Created."	233
"Made."	233
5. Lucifer, The Anointed Cherub & The Angels of God	235
"The Morning Stars"	236
"The Sons of God."	237
6. Satan and The First Garden of Eden	238
7. The Five "I Wills" of Satan.	239
The Judgment.	239
The Earth Was Cleansed.	240
What We Know:.....	240
What We Do Not Know:.....	241
8. Holding to A Young Earth Philosophy of 6,000 Years, Causes Your Witnessing to Be Ineffective.	243
9. After The Rehabilitation of The Earth	244
10. What Does The Bible Say?.....	244
The Anvil Of God's Word.....	245
10b. Creation Diagram Two: Hebrew and English Compared	246
11. The Remodeling.....	253
12. The First Day of Remodeling.	255
<i>Genesis 1:3-5</i>	255
13. Second Day of Remodeling. – The Firmament.....	256
<i>Genesis 1:6-8</i>	256

14. Third Day of Remodeling; Ocean Is Formed;.....	257
<i>Dry Land Appears; Botany Is Re-Born.....</i>	257
<i>Genesis 1:9-13.....</i>	257
15. Botany Not Created; But, “Brought Forth”	259
16. The Fourth Day of Remodeling:Lights In The Firmament	262
<i>Genesis 1:14-19.....</i>	262
17. The Fifth Day of Remodeling.....	265
<i>Genesis 1:20-23. Replenishing The Earth With Aquatic Creatures and Fowl.....</i>	265
18. The Sixth Day of Remodeling.....	266
<i>Genesis 1:24-31. Insects, Animals Made, And Man Created.....</i>	266
"After Their Kind"	270
"Created" and "Made" Concerning Adam and Eve.....	271
Adam and Eve; Both "Created" and "Made".....	276
"Knocking Down the Straw Man.".....	281
19. The Big Lie, No Sin Before Adam	281
<i>Romans 5:12.....</i>	281
20. No Death Before Adam, Another Lie!.....	284
<i>Romans 5:12. The Facts</i>	284
Eve sinned first.....	284
Analysis of Romans 5:12	287
Satan Was Already At Work In The Garden	287
Creation of Angels Not Mentioned In Genesis.....	287
Hell Was Prepared For the Devil & His Angels	289
21. The Hermeneutical Gap Principle.....	293
22. What About the Length of Days In Genesis, Chapter One	298
1. Proof by Biblical Context:.....	299
2. Proof as Spoken by Christ.	299
3. Proof by the Flood.....	299
4. Proof by Botany.	300
5. Proof by Contradiction.....	300
6. Proof by Interpretation.....	301
7. Proof By Reasoning.....	301
XVIII. OTHER BOOKS BY AUTHOR.....	303
XIX. ABOUT THE AUTHOR	305

What This Book Is About

This book is a collection of most of the Question & Answer articles, found on our web site. These articles were originally published as brief, weekly columns in a local newspaper.

Due to the number of questions, we had to publish the book in two volumes. The link is found below. Some are short; some are quite lengthy. The shorter articles are concise answers to questions; but, questions about Bible Doctrine and issues of the day, require more lengthy answers.

They are real questions, asked by real people; both young and old. Sometimes a different question is asked on the same topic.

All are written by Dr. Max D. Younce.

"Study to shew thyself approved unto God, a workman that needeth not to be ashamed, rightly dividing the word of truth. - 2 Timothy 2:15

"Till I come, give attendance to reading, to exhortation, to doctrine." 1 Timothy 4:13

Bible Questions & Answers

www.heritagebbc.com

I. Lordship Salvation

1. *Must We Accept Jesus as Savior and Lord?*

Question: I see that your site says that one must only accept Jesus as their Savior to get to Heaven. Others say that you need to ask Him to be your Savior and Lord. What is the difference?

Answer: The difference is between what God says in the Bible, and what man adds to the Bible by his own reasoning. This could be the difference between going to Heaven; or, going to Hell!

Let us analyze what is meant by those who say “You must ask Jesus to be your Savior and Lord” to have eternal life. I have asked many; and, without exception, they mean they will allow Jesus to have complete control of their lives...for the rest of their lives! Associated with this philosophy is a commonly used phrase which states, “If Christ is not Lord of all, He is not Lord at all.” In other words, if Christ is not in complete control of every aspect of your life, then you probably are not really saved. In reality, they have added serving the Lord, or works, to the salvation message.

This is untrue, as the Word of God teaches that salvation is a free gift. A free gift bought, and paid for, by the death, burial, and Resurrection of Jesus Christ as payment for our sins. Ephesians 2:8,9 explains,

“For by grace are ye saved through faith; and that not of yourselves: it is the gift of God: Not of works, lest any man should boast.”

All the promises and good intentions that a person offers to God, are rendered void as having any merit in attaining salvation. (Romans 4:1-5).

Salvation is obtained by faith in, trusting in, or believing in the finished work of Jesus Christ. All three words, "faith, trust, and belief," are used in Scripture, synonymously. Salvation is not

I. Lordship Salvation

obtained with promises and good intentions. God knows such promises and good intentions will never be kept in their entirety. 1 John 1:8 verifies this,

"If we say we have no sin, we deceive ourselves, and the truth is not in us."

Romans 6:23 says eternal life is a free gift,

"For the wages of sin is death; but the gift of God is eternal life through Jesus Christ our Lord."

This gift is received by faith,

"Therefore being justified by faith, we have peace with God through our Lord Jesus Christ." (Romans 5:1).

"He that believeth on the Son hath everlasting life: and he that believeth not the Son shall not see life; but the wrath of God abideth on him." (John 03:36)

Only the Christian can lead a Christian life; therefore, after we are saved by faith, and faith alone; God wants us to maintain good works.

"For the grace of God that bringeth salvation hath appeared to all men, (11) Teaching us that, denying ungodliness and worldly lusts, we should live soberly, righteously, and godly, in this present world; " (Titus 2:11,12)

Remember, maintaining good works is a *result* of salvation; not a *means* of salvation. There are many who trust Christ as their Savior; but, never serve the Lord the rest of their lives. Are they saved? Of course; but with no rewards at the Judgment Seat of Christ.

"For other foundation can no man lay than that is laid, which is Jesus Christ. (11)

Now if any man build upon this foundation gold, silver, precious stones, wood, hay, stubble; (12)

Every man's work shall be made manifest: for the day shall declare it, because it shall be revealed by fire; and the fire shall try every man's work of what sort it is. (13)

I. Lordship Salvation

If any man's work abide which he hath built thereupon, he shall receive a reward. (14)

If any man's work shall be burned, he shall suffer loss: but he himself shall be saved; yet so as by fire." (1 Corinthians 3:11-15)

II. Marriage & Family

1. *Should a Woman Take Her Husband's Name?*

Question: Is it wrong when in marriage the wife does not take her husband's last name; but is identified by her maiden name throughout their marriage?

Answer: Yes, it is wrong for a woman to do this, as it is nothing more than following the Women's Liberation philosophy. One major problem that surfaces, what shall the children's last name be, the wife's or the husband's?

The cause of this new trend lies in rebellion against God's Word, the Bible. You see, God instituted marriage with Adam and Eve, and set the principles for all mankind thereafter.

In Genesis 2:24, God states that,

"Therefore shall a man leave his father and his mother, and shall cleave unto his wife: and they shall be ONE FLESH."

Since this is impossible, physically, it is therefore referring to the husband and wife being identified by ONE NAME. This is further made clear by Genesis 2:23,

"...she shall be called WOMAN, because she was taken out of man."

Here, the Hebrew for "man" is "ish" (masculine) and the Hebrew for woman" is "ish-shah. The "ish" is taken from Adam's name and the "shah" is the feminine in Hebrew. Therefore, being Adam's wife she has taken Adam's name.

God further addresses them as Mr. and Mrs. Adam in Genesis 5:2,

"Male and female created he them; and blessed them, and called THEIR name ADAM."

I went into a business place sometime back where a preacher's wife was working. I addressed her as "Mrs. (husband's last name)," and she did not respond. I did this two more times

II. Marriage & Family

without being acknowledged. Finally I said, "Are you not so-and-so's wife?" She then answered and stated her maiden name to me. They have no children at this time; but if they did, I wonder if she would want the children to take *her* name, since she refused to take her husband's name?

Human wisdom, in lieu of God's, will always lead to rebellion of God's authority, even in marriage. God's warning is found in Colossians 2:8

... "Beware lest any man spoil you through philosophy and vain (empty) deceit, after the traditions of men, after the rudiments of the world and not after Christ."

This woman, a pastor's wife, is telling you by her example, that it is all right to do as you want; in spite of the prohibition of God's Word.

2. Do We Have to Hate Our Family to Serve the Lord?

Question: What are your thoughts on Exodus 20:12, "Honour thy father and thy mother," and Luke 14:26,

"If any man come to me, and hate not his father, and mother, and wife, and children, and brethren, and sisters, yea, and his own life also, he cannot be my disciple."?

Answer: The word "hate" is a comparative word in the Greek, and not an absolute word. The tender love we have for our father, mother and loved ones is like hatred as compared to the love we should have for our Savior.

A Christian may have unsaved relatives who are opposed to, and try to interfere, with your service to the Lord. They do not want you to witness, saying, "You shouldn't try to shove your beliefs on someone else." They schedule a family reunion on Sunday, and hate it when you don't come until after church.

Years ago, when I told my father I was going to Bible college, he became very upset. I had a good job at that time, three small children, and a beautiful home in the country. My

II. Marriage & Family

dad, whom I loved very much, thought I had "gone off the deep end." I hated to hear the things he said to me; but, I loved him and knew that he was not a mature Christian.

As a Christian, you hate to have relatives tell you not to mention Christ when you are in their home. Yes, you hate the fact they get mad when you will not let them drink alcohol in your home, because they do not respect you. Yes, you hate anything that seems to hinder you from serving the Lord or ruin your testimony!

Sometimes the hardest persecution comes from relatives. Yes, we hate their actions; but, we do not hate them. Why? Because we realize they are not saved or, if a Christian, they have not matured enough to recognize that putting Christ first is where real happiness is found.

*"It is better to trust in the Lord than to put confidence in man."
(Psalm 118:8)*

3. When Does Life Begin?

Question: My friend and I have been discussing when the soul and spirit enter the body? Is there anything in the Bible that can help clarify this?

Answer: First, it must be recognized that a living individual, who starts at conception, is composed of body, soul and spirit. (1 Thessalonians 5:23). There can be no life from the sperm and egg; unless the soul and spirit are present the moment conception produces a new life. The soul and spirit are the life of the body. James 2:26 tells us,

"For as the body WITHOUT THE SPIRIT is dead..."

The spirit is the seat of our intelligence and understanding (1 Corinthians 2:11). The soul is the seat of our emotions and appetites. For example: our soul rejoices (Isaiah 61:10); our soul lusteth (Deuteronomy 12:15); the soul has desires (1 Samuel

II. Marriage & Family

2:16); it sorrows (Mark 14:34); it can hate (2 Samuel: 5:8), and etc.

We never find where the soul and spirit are ever divided. At conception, when life begins, the soul and spirit develop; as they are connected with the body in the womb and on through after birth. God said in Genesis 2:7,

“And the LORD God formed man of the dust of the ground, and breathed into his nostrils the breath of life; and man became a living soul.”

No doctor or neurologist has ever been able to find; or, observe the soul and spirit of an individual. They do know the different functions that the physical matter, called the brain, perform. What they do not know is *how* the soul and spirit controls the brain matter, as the brain is only dead tissue—unless the spirit of life is in the body.

In Psalm 139:14 we are told,

“I will praise thee; for I am fearfully and wonderfully made:...”

Since,

“the body without the spirit is dead”; (James 2:26a)

...therefore, conception could not produce life unless the spirit is present. Life begins at conception; therefore, abortion is nothing more than *First Degree Murder* in the eyes of God!

When sin entered into the garden, God pronounced the death sentence, physically and spiritually. God never remitted the physical consequences of sin (Romans: 3:23); but, did remit the eternal consequences of Hell, on one condition. You must accept Jesus Christ as your Savior. In John 3:16, God exhibited his love for the sinner.

“For God so loved the world, that he gave his only begotten Son, that whosoever believeth in him (Christ) should not perish, but have everlasting life.”

II. Marriage & Family

4. Is An Unbelieving Spouse A Believer If He Marries a Believer?

1 Corinthians 7:14

Question: Does 1 Corinthians 7:14 mean that if a lost person marries a saved person, they are saved because of the marriage?

Answer: 1 Corinthians 7:14 says,

“For the unbelieving husband is sanctified by the wife, and the unbelieving wife is sanctified by the husband: else were your children unclean; but now they are holy.”

The situation presented by this verse is that the marriage, no doubt, began with two unbelievers; with the wife getting saved after they were married. In 2 Corinthians 6:14, God forbids the marriage of a Christian to a non-Christian.

“Be ye not unequally yoked together with unbelievers: for what fellowship hath righteousness with unrighteousness? And what communion hath light with darkness.”

In 1 Corinthians 7:14, the word “sanctified” basically means “set apart.” This has nothing to do with the salvation of the one who is the unbeliever; but, rather, has to do with the blessings he receives by being set apart in marriage to his Christian wife. God is going to bless his wife for her faithfulness; therefore, those blessings on the home are enjoyed by him also, because of being “set apart” in marriage to her. In other words, from God’s viewpoint, He recognizes the marriage as a legitimate marriage, even though one is a believer and one is not. If not, then in God’s eyes the children would be unclean (i.e., illegitimate); but, now they are holy. They are recognized as legitimate children from a legitimate marriage.

A practical application surely can be obtained from this verse. An unbelieving husband and children being in the household with a Christian mother puts them in a position of particular privilege. You see, both husband and children are set apart (i.e. “sanctified”) under the influence of a Christian wife and mother to hear the Gospel and be saved; also by the

II. Marriage & Family

testimony of her life. 1 Peter 3:1 explains,

Likewise, ye wives, be in subjection to your own husbands; that if any obey not the word, they also may without the word be won by the conversation of the wives."

Many wonderful Christian women have won their husbands and children to Christ and experienced Proverbs 31:28.

"Her children arise up, and call her blessed; her husband also, and he praiseth her.

5. *What Does The Bible Say About Interracial Marriages?*

Question: What does the Bible say about interracial marriages? Do Ezra 10 and Nehemiah 13 teach that God's people shouldn't marry outside of their race. What about an office in the church? How does the church help such families?

Answer: Whether interracial couples are dating, or actually married; when they come to your church you should treat them like everyone else and make them feel welcome. They are human beings with feelings, just like you and I. God loves all the same. "For God so loved the world..." (John 3:16) The important question is...are they saved or lost? The primary concern of the pastor should be their salvation. Forget counseling until they accept Christ as their Savior, and are indwelt by the Holy Spirit. (Ephesians 1:13). Trying to counsel the unsaved in spiritual things is difficult, as described in 1 Corinthians 2:14,

"But the natural man receiveth not the things of the Spirit of God: for they are foolishness unto him: neither can he know them, because they are spiritually discerned..."

If the interracial couple are already married and sincerely want to serve the Lord with your church, they should not be rejected. They will have enough rejection from others who are unsaved. If not married, I would surely point out the negatives they may encounter by such a marriage. Love blinds many to the truth of the hardships they or their children may have to face because of social prejudice. Should they want you to marry them,

II. Marriage & Family

then you have to make the decision based on whether you think the marriage is in the best interest of both parties. These are not easy decisions for a pastor. Be kind, pray a lot, and go slow.

The only marriage restriction, Biblically, is that we are not to marry a saved person to an unsaved person.

In Ezra and Nehemiah, the restriction was concerning Israelites marrying heathen women who worshipped heathen idols and did not worship the God of Israel—strictly prohibited by Mosaic Law. (Deuteronomy 7:1-4; Ezra 9:1,2).

In Nehemiah, the restriction was against the Ammonites and Moabites for specific actions against the God of Israel and His people. (Nehemiah 13:1,2; Deuteronomy 23:3,4; Numbers 25:1,2). It had nothing to do with race; but, with God's people (believers) uniting in marriage with the ungodly (unbelievers).

“Can two walk together, except they be agreed?” (Amos 3:3)

“Be ye not unequally yoked together with unbelievers...” (2 Corinthians 6:14).

What about holding an office? In most Baptist churches, deacons are nominated; and then elected, or rejected, by a vote of the congregation. You do not alter the procedure because of a person's nationality. This will be a real test of your deacons, congregation, and your leadership in this matter.

Galatians 3:28 and Acts 10:34 are God's view concerning the races of people. Your responsibility is to the Lord and His word, which has precedence over someone else's opinion. (Proverbs 29:25; Psalm 118:8,9; Jeremiah 17:5-8; Proverbs 3:5,6). This may be your opportunity to instruct your congregation as to God's Word on the subject, in lieu of some adverse opinions.

6. What Does The Bible Say to Abused Wives?

This article was compiled from several letters on this

II. Marriage & Family

subject. In essence..."My husband does not claim to be a Christian. He abuses myself and our children with his uncontrolled rages and threats. Also, this leads to physical abuse of myself and the children. He says he cannot control himself when he gets upset, but refuses to seek help. I am a born-again Christian. What advice can you give me?

Answers: First, let me say that you certainly do have my sympathy and concern. Verbal and emotional abuse can, in a moment of time, turn to physical abuse, as you have described. I am sorry to hear that you are in the multitude of abused wives. You need to think of the effect this has on the children, also. Remember...you, as a Christian, are just as entitled to protection under civil laws as anyone else.

A good Scripture to read is 1 Corinthians 7:13-15. Here we find a Christian wife with an unbelieving husband. If he is "pleased to dwell with her", she is not to leave him. However, I believe that being "pleased to dwell" means, dwelling with the wife in the manner Christ gives in Scripture: Ephesians 5:25,28-29,

"Husbands, love your wives, even as Christ also loved the church, and gave himself for it;...So ought men to love their wives as their own bodies. He that loveth his wife loveth himself. For no man ever yet hated his own flesh; but nourisheth and cherisheth it, even as the Lord the Church."

Further, we find 1 Peter 3:7 says,

"Likewise, ye husbands, dwell with them according to knowledge, giving honour unto the wife, as unto the weaker vessel, and as being heirs together of the grace of life; that your prayers be not hindered."

These are two good definitions of what it means to be "pleased to dwell" with a wife. A husband, who loves you, would certainly try to do these things. Even using the excuse he is mentally ill; he needs to get treatment so he doesn't act this way. I feel his "mental illness" could be just an excuse; so, he doesn't have to control his anger or himself. If your husband were

II. Marriage & Family

pleased to dwell with you, in the marriage bond; it would mean that he would love you and would not abuse and mistreat you.

One course of action I would recommend would be a legal separation, due to safety precautions. See a lawyer and get a legal separation with a RESTRAINING ORDER! If your husband is mentally ill and is treating you this way, it must be because he is doing nothing in the way of helping himself through treatment and medication. If, in the course of an agreed-upon period of time, you see no evidence of genuine change on his part, i.e. seeing a doctor, medication, etc., and no change in behavior, you can prayerfully consider your next step.

This is not the result of your actions. It is the result of HIS actions. Because of his actions, he has departed. I feel one who behaves in this manner has “departed” from his marriage commitment, of his own choice. I believe 1 Corinthians 7:15 teaches that the wife, in such cases, is not under bondage to stay in the marriage.

You have the scriptural responsibility to keep yourself and your children safe. If your husband thinks a marriage license equals "a punching bag, verbal or otherwise; he has “departed” from the marriage. You are "not under bondage." Too many wives in your situation have believed “mere words" and death and injury have resulted. The civil laws are for you, too.

Rest assured, you will be in our prayers. God bless you!

7. *Should a Protestant Marry a Roman Catholic?*

Question: Is there any scriptural advice concerning Protestants marrying Catholics?

Answer: Romans 16:17,18 states,

“Now I beseech you, brethren, mark them which cause divisions and offenses contrary to the doctrine (i.e., the Word of God) which ye have learned; and AVOID THEM. (17) For they are such that serve not our Lord Jesus Christ, but their own belly;

II. Marriage & Family

and by good words and fair speeches deceive the hearts of the simple.” (18)

2 Corinthians 6:14 is very clear concerning whom a Christian should marry.

“Be ye not unequally yoked together with unbelievers: for what fellowship hath righteousness (the saved) with unrighteousness (the unsaved)? And what communion hath light (the saved) with darkness?(the unsaved).”

Concerning your question regarding Protestants, a distinction needs to be made. The Roman Catholic Church seems to list all denominations outside itself as Protestant, which incorporates myriads of cult religions along with true Christianity. The Roman Catholic Church, itself, is a man-made religious organization which propagates itself to the world as the only true church.

Your question really becomes, “Should a Christian marry a religious unbeliever?” In other words, if a person believes what the Roman Catholic Church teaches concerning salvation, they are not a Christian; but lost, facing eternal damnation. The following are just a few of the claims of Catholicism that are exposed as lies and false teaching by the Word of God.

1.a. Salvation: Teaching of Catholicism according to the Council of Trent. (1545-1563). “If anyone should say that justifying faith is nothing other than a trust in God’s mercy remitting sins on account of Christ or that it is simply trust itself by which we are justified, let him be Anathema (i.e., “accursed”).”

1.b. Salvation: According to the teaching of God’s Word, the Bible. Since Catholicism claims to follow Peter with the succession of the Popes; then, why do they deny Peter’s teaching now? Notice how the Apostle Peter’s words contradict the teaching of Catholicism. Here are Peter’s words at the Jerusalem Council in Acts 15:9,11.

II. Marriage & Family

“And put no difference between us (Jews) and them (Gentiles), purifying their hearts by FAITH. But we believe that through the grace of the Lord Jesus Christ we shall be saved, even as they.”

The Roman Catholic Church doesn't even believe Peter, who they claim was the first pope! They deny the Bible again by claiming Peter to be a pope, when Peter, himself, said, he was an ELDER, not a pope. Notice 1 Peter 5:1,

"The elders which are among you I exhort, WHO AM ALSO AN ELDER..."

The terms “elder, overseer, and bishop” are used synonymously for the office of pastor.

Ephesians 2:8,9 clearly exposes the false teaching of good works for salvation by the Catholic Church.

‘For by grace are ye saved through faith; and that not of yourselves: it is the gift of God. NOT OF WORKS, lest any man should boast.’

The amazing thing is that the Douay Roman Catholic Bible says,

“Not the OUTCOME of works.”

The New American Bible, now used by Catholics, states in Ephesians 2:8,9 that salvation is not of works; yet, the priests don't even believe their own Bible and teach exactly opposite of what it says. If you believe the Catholic Church, you are lost on your way to Hell. If you believe what the Bible teaches about salvation, that eternal life is result of simply believing that Jesus Christ died to pay for your sin, you are saved and on your way to Heaven. Period!

2.a. Catholicism: The priests claim they are the mediators between God and men.

2.b. The Bible, God's Word: 1 Timothy 2:5, makes the Roman Catholic Church a liar.

“For there is one God, and one mediator between God and men, the man Christ Jesus.”

II. Marriage & Family

NOT the priest.

3.a. Catholicism: The priests love to be called “Father.”

3.b. The Bible, God’s Word: Jesus Christ speaking Himself said never call a religious leader “Father” in Matthew 23:9.

“And call no man your father upon the earth: for one is your Father, which is in heaven.”

This, of course, is not speaking of your biological father. Notice when we address our real spiritual father in Matthew 6:9,

“After this manner therefore pray ye: Our Father which art in heaven, Hallowed by thy name.”

Read the first seven verses of Matthew 23 and you will find that pride is the reason they want to be addressed as such.

Personally, I have talked to approximately 150 priests and have had some to our home for lunch to discuss their beliefs. One priest told me, honestly, if they could get people to address them as “Father,” they would believe anything else they were taught.

4.a. Catholicism: Uses alcoholic wine for the Lord’s Supper.

4.b. The Bible, God’s Word: In Leviticus 10:9, God forbids the priest from bringing any alcoholic wine or drink into the congregation. Notice God’s Word,

“Do not drink wine nor strong drink, thou, nor thy sons with thee, when ye go into the tabernacle of the congregation, lest ye DIE...”

In the New Testament, at the Lord’s Supper, it is made perfectly clear that grape juice, NOT alcoholic wine is to be used. “*Fruit of the vine*” is always sweet grape juice and is used specifically in distinction from alcoholic wine. It is used in the account of the Lord’s Supper in Matthew 26:29; Mark 14:25; and in Luke 22:18. So...what the Catholic priest is doing today is not only defying the Word of God; but, having you follow *him* instead of the Word of God!

5.a. Catholicism: Forbids the priest to be married , using the

II. Marriage & Family

philosophy they can devote more time to their ministry.

5.b. The Bible, God's Word: The Old Testament priests were required by God to be married. We find in Leviticus 21:13,14,

"And he (the priest) shall take a wife in her virginity (v.13)."

Notice the priest is ordered to be married, if he is going to serve as a priest. The Bible says "*shall take*," not "may take." In other words, he has no choice in the matter. If he is going to be a priest, he has to be married. Period! Verse 14 gives the qualifications for whom he shall marry.

"A widow, or a divorced woman, or profane, or an harlot, these shall he not take: but he shall take a virgin of his own people to wife."

(1). Pastors are to be married. 1 Timothy 3:2 makes this unquestionably clear.

"A bishop then must be blameless, the husband of one wife, vigilant, sober, of good behaviour, given to hospitality, apt to teach."

(2). Deacons in the church must also be married. Notice Verse 12 of the same chapter.

"Let the deacons be the husbands of one wife, ruling their children and their own houses well."

(3). It is too bad when the Pope rules contrary to the Word of God. Is it any wonder that the priesthood is saturated with pedophiles and homosexuals. In fact, the Bible says the teaching and forbidding of the priest to marry is the Satanic doctrine of demons, not the Holy Spirit. We find this in 1 Timothy 4:1,3.

"Now the spirit speaketh expressly, that in the latter times some shall depart from the faith, giving heed to seducing spirits, and doctrines of devils (demons);" (1)

"FORBIDDING TO MARRY and commanding to abstain from meats, which God hath created to be received with thanksgiving of them which believe and know the truth."(3)

II. Marriage & Family

I wonder how many follow the Satanic teaching of not eating meat on Friday?

6.a. Catholicism: Teaches the gullible that the Pope is infallible. Quoting from the writings of Catholicism, here is what they want you to believe. Roman Catholic doctrine further states that whatever the Pope says is infallible. (Read Romans 3:23.)

"It follows therefore that the Pope is a supreme judge in all manners of faith and morals, and his pronouncements on these matters have the guarantee of INFALLIBILITY."

(1). The Roman Catholic Church wants you to believe that the Pope rules the whole world and teaches all Christians. Here is their declaration, according to the COUNCIL OF FLORENCE. (1438-1443).

"We define furthermore that the Holy Apostolic See and the Roman Pontiff hold primacy over the WHOLE WORLD, and that the Roman Pontiff, himself, is the successor of St. Peter, Prince of the Apostles, the true Vicar of Christ, head of the entire church, father and teacher of all Christians..."

6.b. The Bible, God's Word: Proverbs 30:5 says that *"Every word of God is pure."* It does not say that every word of the Pope is pure. As previously shown, the pope not only contradicts, but adds to and takes away from the Word of God. As one compares the word of the Pope with the Word of God, it is easy to see who is lying and teaching the people falsely. Proverbs 30:6 says,

"Add thou not unto his words, lest he reprove thee, and thou be found a liar."

Romans 3:4 nails it down!

"...Let God be true, but every man a liar..."

I have only listed a handful of the multiplicity of the false teaching of Catholicism.

A true, born-again Christian is one who is trusting completely, with no reservations, that Jesus Christ, perfect and sinless, took on human flesh, went to the cross, was crucified, buried and risen from the dead as full payment for all their sins,

II. Marriage & Family

past, present and future. No works of their own are involved. They now possess the peace of God, knowing they will never perish, but have everlasting life and are passed from death unto life.

I cannot think of an exception of those I have talked with who have married a Catholic. The priest will not marry the couple unless the Christian, who is non-Catholic, signs an agreement to permit their children to be raised as Catholic. May I say, the Catholic person may very well be a nice, wonderful individual, man or woman. What is overlooked is their spiritual beliefs, and as time goes on, these will affect the relationship of the marriage; which, in turn, will have a tremendous effect upon the children.

The conflict is really over the Word of God. One believes the teaching of the Catholic Church and the other believes the teaching of the Word of God. They are diametrically opposed! This can change sweetness into bitterness real fast, and does NOT make for a lasting and happy marriage. Romans 16:17 and 2 Corinthians 6:14 advise that one should avoid the situation of marriage, where these spiritual conditions persist.

No, a Christian should not marry a Catholic, and should not even allow the relationship to progress until the spiritual conflict is resolved. If it cannot be resolved, it is much better to break off the relationship, and still be friends; than to pursue it and have a marriage of compromise and heartache.

III. Ministry

1. *Does Divorce Disqualify a Man for the Pastorate? Case 1:*

Question: Our church has been without a pastor for quite a while and the board will not consider a pastor who has been divorced. Are there Scriptural grounds for this?

Answer: There are many circumstances concerning pastors that have been divorced. Some would disqualify and some would not.

We will call this Case One, which would not disqualify a man from the pastorate. The qualifications for a pastor are given in 1 Timothy 3:2-4. He must be married and the husband of one wife (V.2) Should the man have been married and divorced before he became a Christian, by accepting Jesus Christ as his personal Savior, and has remarried since; the divorce would not disqualify him from the pastorate. The reason is that, when he trusted Christ for his salvation, every sin was forgiven including divorce.

2 Corinthians 5:17 says,

“Therefore if any man be in Christ, he is a NEW CREATURE (Greek, “creation”): old things are passed away; behold, ALL things become new” (That is in God’s eyes concerning you.).

The divorce, as well as all sin, are non-existent in God’s eyes, as Acts 13:39 states,

“And by Him (Jesus Christ) all that believe are justified from all things...”

The Word of God in Psalm 103:12 lets us know that,

“As far as the east is from the west, so far hath he removed our transgressions from us.”

In God’s mind, at salvation, the man’s divorce is as though it never existed. The Christian has God’s Word about this in Isaiah 43:25,

“I, even I, am he that blotteth out thy transgressions for mine own sake, and WILL NOT REMEMBER THY SINS.”

III. Ministry

Therefore, going back to God's Word in 1 Timothy 3:2 concerning "...*the husband of one wife,*" would not be referring to a previous marriage before one was a Christian; but, to more than one wife at the present time.

I personally know of pastors, youth directors, choir directors, deacons, Sunday school teachers, etc. who fulfill their positions and are doing a wonderful work for the Lord, who had previously been divorced prior to being saved. At salvation, God is not interested in our past sins any more, as they are nailed to Calvary's cross; but, He is sure interested in our future in serving Him. Let us not hinder God's will or leading for a pastor, deacon, Sunday school, etc. who has been divorced prior to being saved. The sins God has no remembrance of need not be resurrected by a church board interfering with the will of God!

2. Does Divorce Disqualify a Man from the Pastorate?

Case 2:

Question: Our preacher's wife divorced him for another man. Can he remain in the ministry as a pastor?

Answer: Your pastor fulfilled the qualification of being married to occupy the position of Pastor. 1 Timothy 3:2 states, in part, that he must be "...*the husband of one wife...*" Since the divorce was pursued by his wife for another man; that would be considered adultery. Since your pastor is the innocent party, I do not see any reason for him to abandon God's calling because of his wife's sin. She is the one who walked out on the Lord because of the...

"...lust of the flesh, and the lust of the eyes..." (1 John 2:16)

Romans 14:12, speaking of our own responsibility to the Lord, says,

"So then every one of us shall give account of himself to God."

Your pastor is not responsible for his wife's actions. She

III. Ministry

must give account to God for her unfaithfulness herself.

The problem that arises out of a situation such as this is; that, many times the people of the church will be divided over whose fault this was. There are so many things that one may never know about the situation unless you were a “little spy” in their home 24 hours a day. Some may say the pastor mistreated his wife; as a result, forcing her into the arms of another man. Others may be convinced she was running around while they were still married, as she showed signs of disinterest in the Lord’s work. In this particular case, let us assume that the pastor was a loving husband, faithful to his calling, and knew nothing about his wife’s extra-marital affair until the divorce. I know a wonderful pastor that I went to college with, who endured this kind of trouble. He is still in the ministry.

Back to our original question, “Should the innocent pastor resign his pastorate because of his wife’s adultery and institution of the divorce?” I do not believe he should forsake his calling because his wife has forsaken hers. Romans 11:29 tells us,

“For the gifts and calling of God are without repentance.”

“Repentance,” here, is the Greek word “ametaemelos” and means “irrevocable.”

Now the question becomes, “Should he remain at his present church; or, assume a pastorate in another church?” I do not believe anyone except the Pastor can make this decision. I personally would never advise a pastor to stay, or go, in a situation like this. If I knew this pastor well I would try my best to comfort him, knowing his heart is broken; giving him the assurance that the Lord has not walked out, or forsaken him, as his wife has done. Hebrews 13:5b, 6 reminds us,

“...for he hath said, I will never leave thee, nor forsake thee. So that we may boldly say, The Lord is my helper, and I will not fear what man shall do unto me.”

I may only make a few suggestions to my friend. (1). Meet

III. Ministry

with your deacons, relate the truth of the situation and see what their feelings are. (2). Meet with the congregation and do the same. (3). Talk with the Lord and seek His guidance and peace in determining whether you should stay or seek another pastorate or another avenue of ministry. (4). No one can give you the final direction and peace, but the Lord.

3. *Can a Man Who Has Divorced and Remarried Be a Pastor? Case 3:*

Question: Can a Man Who Has Divorced and Remarried Be a Pastor?

Answer: The answer becomes very simple when we go back to when we were saved. The question becomes, “How many sins did Christ forgive when we trusted Him as our Savior? In Isaiah 38:17 the Word of God tells us,

“...but thou (God) hast in love to my soul delivered it from the pit of corruption: for thou (God) hast cast ALL my sins behind thy back.”

In other words, in God’s eyes, my sins no longer exist. In Matthew 26:28 we are told,

“For this is my blood of the new testament, which is shed for many for the remission of sins.”

The Greek word for “remission” is “aphesis” and means “a dismissal, release, completely canceled”; and is used for the forgiveness of sin, and translated “remission” in this verse. Also notice the word “sins,” it is in the plural. Therefore, at salvation, ALL sins are forgiven, canceled, and dismissed!

Dr. Luke, stating by the inspiration of the Holy Spirit in Acts 13:38,39 declares that,

“...through this man (Jesus Christ) is preached unto you the forgiveness of SINS: And by him (Christ), all that believe are justified from ALL THINGS, from which ye could not be justified by the law of Moses.”

III. Ministry

Notice again, that the word “SINS” is plural, as every sin committed prior to salvation is forgiven. The word “justified” is a legal term meaning, “Declared 100% righteous with a full acquittal of my sins.” At salvation, ALL of my sins are forgiven, and forgotten, in God’s eyes.

Now, therefore, bear with me as we go to one more verse found 2 Corinthians 5:17,

“Therefore if any man be in Christ(i.e. salvation),he is a new creature (creation): old things (sins prior to salvation) are passed away; behold ALL things are become new.”

This is a positional truth; that is, this is the way God looks upon the new Christian. The prior life of the person, now saved, is viewed, in God’s eyes as, *“old things that have passed away.”* The Greek for “pass” is “parerchomai” followed by “away” and means “to perish.” God views the sins of a person, committed prior to salvation, as having perished from His sight and never again brought into remembrance. Upon receiving Jesus Christ as our Savior, God looks upon his new child (John 1:12) as a brand new creation, having all of his sins forgiven, having been justified and declared righteous with a full acquittal of ALL past sins.

With the foregoing in mind, let us return to our original question. “Can a man who has been divorced and remarried, prior to being saved, occupy the office of pastor or deacon?” The Scriptures clearly state in 1 Timothy 3:2,12, that both must *“be the husband of one wife.”* The qualifications given for the office of pastor and deacon apply to only the life of a Christian; since they have become a Christian. The qualifications do not apply to a man’s life prior to being saved. There are reasons for this:

1. All sins he committed prior to salvation, as the aforementioned Scriptures plainly state, are forgiven, forgotten, passed away, or perished in God’s sight—including divorce.

2. If one is going to hold that divorce prior to being saved disqualifies a man from these two offices, then, we have a real

III. Ministry

problem! Being honest with the qualifications in 1 Timothy, one would have to apply the same restrictions to his wife for Sunday School teaching, etc.

3. Those who endorse the view that divorce and remarriage prior to salvation disqualifies a man from the office of pastor or deacon, seem to overlook the Scriptures that apply to his wife also.

4. Now, let us look at ALL the qualifications required to be a pastor as found in 1 Timothy 3:2-4.

Verse 2: "A bishop (pastor) must then be blameless, the husband of one wife, vigilant, sober, of good behaviour, given to hospitality, apt to teach;"

Verse 3: "Not given to wine, no striker, not greedy of filthy lucre; but patient, not a brawler, not covetous."

Verse 4: "One that ruleth well his own house, having his children in subjection with all gravity;"

Therefore, for a person to pick out just one of the 14 qualifications for a pastor, from a man's life prior to salvation, would be mutilating, and totally dishonest with these Scriptures. One cannot just pick out a piece of Scripture and apply it to fit one's own preconceived ideas, with disregard of the text and context in which it appears. Since all sins are passed away into oblivion at salvation (2 Corinthians 5:17); the qualifications can only apply to a man after he is saved, thus a Christian.

Consequently, the "husband of one wife" could be applied to two situations disqualifying a man from the position of pastor or deacon.

- a. A man practicing polygamy, having a plurality of wives.
- b. A Christian who divorces and remarries after he is saved.

The love, grace, and forgiveness of God can surely be seen in His use of the Apostle Paul. Here, God took a man who was a murderer before he was saved, and made him a missionary. One

III. Ministry

who was a blasphemer, and made him a blessing, using an ex-persecutor as a preacher. 1 Timothy 2:7, speaking about the Apostle Paul, tells us that...

“Whereunto I am ordained a preacher, and an apostle, (I speak the truth in Christ, and lie not;) a teacher of the Gentiles in faith and verity.”

At Paul’s salvation, all his previous sins, including his murdering of Christians, were forgiven as he was now a new creation in Christ Jesus. I believe, if Christ’s payment on the cross took care of the sin of murder, is there any doubt it can take care of the sin of divorce and remarriage prior to being saved? Since God forgave Paul as a murderer and used him greatly, including writing 14 of the 27 Epistles of the New Testament, then divorce and remarriage should be no problem. God has used many of these men as pastors, deacons, and missionaries, etc.

IV. Noah's Ark

1. How Could Noah's Ark Hold All The Species of Animals?

Question: How Could Noah's Ark Hold All The Species of Animals?

Answer: In answering this question, there are several facts that need to be recognized. Let me list them for you:

1. The ark was not shaped like a ship, but was shaped as a rectangle, like a three-story barge. It was never built to sail, only to float.

2. Size of the ark: The length was 450 feet, the width was 75 feet, and height was 45 feet. (Genesis 6:15). The cubit was approximately 18 inches, which was the measurement taken from the elbow to the end of the middle finger.

3. Capacity. There were 33,750 square feet on each of the three floors, making a total floor space of 101,250 square feet. This is equivalent to 1,518,750 cubic feet.

4. Capacity equivalence. The area of the ark is equal to approximately 522 standard stock cars, or 8 freight trains of 65 cars each.

(Doing the Math, these stock cars would have a carrying capacity of approximately 23,365 cubic feet. There are approximately 9 different types of railroad cars, each with different possible lengths and many variations. For the purpose of this article, our stock cars have a carrying capacity of approximately 23,365 cubic feet.)

Note: If one stock car holds about 25 cattle, a double deck car can haul about 250 pigs or sheep. With this carrying capacity there would be no problem transporting the original species. Two trains hauling 73 cars each could carry about 35,000 animals, to give some idea of the ark's carrying capacity.

5. Worms, insects, and similar small creatures, averaging 2

IV. Noah's Ark

in. on the side, would only require 21 more cars for over 1,000,000 individuals.

Of the clean beasts they were to take by sevens, male and female, to be used for an offering (Genesis 8:20) and for food (Genesis 9:2,3). The unclean, male and female by two, this was just to replenish the earth.

Today we have over 500 varieties of the sweet pea, developed from a single type since the year 1700, with more being developed every year. Also, there are 200 distinct varieties of dogs (also expanding) that have developed from a very few wild dogs. Only the male and female of the original species were taken, not all of the varieties.

Note: The flood took place approximately 1656 years from the Creation. Approximately 2400 years after the flood, Christ was born. We are living approximately 2,010 years since Christ was here, thus totaling approximately 4,410 years since the flood. It is not difficult to realize, over a period of 4,410 years, why we have all the varieties of animals, insects and plants that have developed from the original species.

2. Were There Rooms in the Ark?

Question: My 4th and 5th Grades and I are building a 1/64th scale model of Noah's Ark. We have done a lot of math on this project. Are there measurements on the design of the ark's interior? This project was done along with a year-long study of the challenges Noah had in following God's will.

Answer: In your study of Noah's life, you must conclude...God made every provision needed for those in the ark...including the size of the "accommodations".

"Make thee an ark of gopher wood; rooms shalt thou make in the ark, and shalt pitch it within and without with pitch." (Genesis 6:14).

IV. Noah's Ark

Verses 15 and 16 of Genesis 6 continue with the rest of the specifications for the ark. Pertinent to your question, the Hebrew word for "rooms" comes from a prime root meaning "to nestle, i.e. build or occupy as a nest." It brings the idea that what God wanted built for "rooms" was the type of place each animal would feel comfortable in. Would a loving God do less? The Bible does not specify dimensions or a description, other than the meaning of the Hebrew word.

Because he believed God's Word, Noah built the ark; and he and his family entered in, and were saved from the judgment of the flood. By doing this, Hebrews 11:7 tells us he became an *"...heir of the righteousness which is by faith."* The ark is a picture of our salvation in Christ. The word translated "pitch" in Genesis 6:14, is the same word translated "atonement" in Leviticus 17:11.

It is Christ's atonement for sin that keeps out the waters of judgment; and makes the believer's position "in Christ" safe and blessed. If we are "in Christ" we become "heirs of the righteousness which is by faith."

Are you in the Ark of Safety?

"And be found in him, not having mine own righteousness, which is of the law, but that which is through the faith of Christ, the righteousness which is of God by faith:" (Philippians 3:9)

3. *What Period in History Did Noah Live?*

Question: What period in History did Noah live? How does that story compare to the "Great Flood" in the Epic of Gilgamesh for Mesopotamian literature?"

Answer: According to Biblical Chronology, the flood occurred in approximately 2348 B.C. in the 600th year of Noah's life. (Genesis 7:11).

Gilgamesh, as a historical figure, was a king of Sumer, city

IV. Noah's Ark

of Erech, second of cities founded by Nimrod. (Genesis 10:10,11). You can read about him in the Gilgamesh Epic, which contains one of the many flood accounts found among many peoples. It is a great proof that all peoples existing today descended from Noah; as these ancient peoples carried the story with them as they spread out from a central place over all the earth.

These ancient traditions are not the inspired Word of God; but have many similarities: a universal flood, a few people saved in a boat, others destroyed because of sin. The Bible contains the only accurate account of this great event. (2 Timothy 3:16; Hebrews 1:1; 2 Peter 1:21).

I would suggest going to a library to look this up in a *Zondervan's Pictorial Encyclopedia of the Bible*. It is a 5-volume set and contains much fine information on this subject. It gives the exact comparison you are looking for; and which space prevents me from discussing here.

Thank God for His Inerrant Word and Record concerning Christ's payment for our sins. John 3:16 states it so simply,

"For God so loved the world, that he gave his only begotten Son, that whosoever believeth in him should not perish, but have everlasting life."

1 John 5:11 agrees,

"And this is the record, that God hath given to us eternal life, and this life is in his Son."

4. *How Long Did It Take Noah to Build the Ark?*

Question: How long did it take to build Noah's Ark, and where can I find the answer?

Answer: In 1 Peter 3:19,20 we read,

"By which also he (Christ) went and preached unto the Spirits in prison. (19) "Which sometime were disobedient, when once the longsuffering of God WAITED in the days of Noah, WHILE

IV. Noah's Ark

THE ARK WAS A PREPARING, wherein few, that is, eight souls were saved by water." (20)

Now, notice Genesis 6:3,

"And the Lord said, My spirit shall not always strive with man...yet his days shall be an hundred and twenty years."

God's longsuffering was for the 120 years it took Noah to complete the ark; and then, God's judgment of the flood came.

In 1 Peter 3:19, Christ preached through Noah just as He uses the Christians, today, who are His ambassadors. (2 Corinthians 5:20). God describes the people Noah preached to in Genesis 6:5,

"...every imagination of the thoughts of his heart was only evil continually."

They were prisoners to their own sin. The word *prison* is the Greek "phulake" and is never—anywhere in the New Testament—used in reference to Hell, or translated as such.

This alone disproves the false claim of some that, "After you die and are in Hell, you get a second chance." That is *exactly* what Satan would like you to believe! Read Luke 16:19-31. Perhaps this man in Hell believed Satan's lie that he would have a second chance; but, found out too late that he had been deceived.

When you die, your destiny is sealed forever. That is why the Lord stated,

"...behold, now is the accepted time; behold, now is the day of Salvation." (2 Corinthians 6:2).

"It is a fearful thing to fall into the hands of the living God."

...without Christ as your Savior. (Hebrews 10:31).

God destroyed millions during the flood, the multitude who didn't believe. You can follow the multitude into Hell, or the minority into eternal life. It is your choice. John 3:36 makes it perfectly clear,

IV. Noah's Ark

"He that believeth on the Son hath everlasting life: and he that believeth not the Son shall not see life; but the wrath of God abideth on him."

V. Occult

1. Explain the "Light at the End of the Tunnel" & NDEs?

Question: I have heard so many on television and radio talk about seeing a great light at the end of the tunnel and the peace they have now. Is there anything in the Bible about this?

Answer: These visions or dreams are nothing more than Satan's counterfeits of God's real peace. The real peace a Christian has is in trusting Jesus Christ as the One who paid for our sins on the cross. Romans 5:1 is God's peace,

"Therefore being justified (declared righteous) by faith, we have PEACE with God through our Lord Jesus Christ."

I have never heard any of these, claiming the white light experience, say anything about Jesus Christ.

Satan is a liar and murderer (John 8:44). He can put wrong thoughts into your mind. Acts 5:3 is a good example,

"And Peter said, Ananias, why hath Satan filled thine heart (conscience) to lie..."

Satan can give false visions, as he did to Eliphaz in Job 4:12-16. Eliphaz thought his "visions of the night" were from God and that *God's word and advice* were to be applied to Job. Eliphaz proceeds to instruct Job in Chapters 4,5,15, and 22. Everything Satan gave to Eliphaz was right about God's righteousness, holiness, judgment, veracity, etc. The lie was—making Eliphaz think all of this rebuke was for Job's hidden sins; when, in reality, none of it was true.

The Lord speaks to Eliphaz in Job 42:7,

"My wrath is kindled against thee...for ye have not spoken of me the thing that is right, as my servant Job hath."

(See Verse 8 also.)

John 3:36 says,

"He that believeth on the Son hath everlasting life."

— not the white light at the end of the tunnel!

2. *Knitting Shawls and a "Mother God!"*

Question: Dear Dr. Younce. My sister sent me this site and wanted my opinion on it. The organization is The Shawl Ministry. I think it sounds a little like using prayer beads to me. I am not impressed; but, I could be wrong. I can remember a story of some big family where the mother used something to cover herself when she was either resting or praying as a sign that no one should disturb her. My sister is alone and in so much pain all the time, I can see where she is looking for some comfort; even in making shawls and giving them to someone else. What do you know about this and what is your opinion?

Answer: I liked your story about the mother who covered herself when she prayed (or rested) as a sign that no one should disturb her. I think very possibly she took to her heart Matthew 6:6 which says,

"But thou, when thou prayest, enter into thy closet, and when thou has shut thy door, pray to thy Father which is in secret; and thy Father which seeth in secret shall reward thee openly."

The covering was her "prayer closet" where her prayers would not be interrupted, and she could have blessed fellowship with her Savior.

I did as you requested and visited the website for this shawl ministry. What I found was deeply disturbing. Never once did I find the name of God, the Father, the Holy Spirit, or our Lord and Savior, Jesus Christ! What I did find was the heresy of a "Mother Goddess."

I looked up the people who began this ministry, Janet Bristow and Victoria Galo, and the Institute they graduated from at Hartford "Seminary" or "cemetery." This was a program of "Applied Feminist Spirituality." When I get to the word "feminist" it immediately registers "rebellion" in my brain and I

V. Occult

was absolutely right. These are women who reject the Bible truth of God, the Father, and say God is being too authoritarian or mean; and gives His love and forgiveness only if we meet certain conditions.

God is not being mean when he says salvation only comes through accepting Christ's death on the cross as the sin payment for the world. (John 1:12; John 3:16). After all, God loved the world so much that He gave us the ultimate gift of His Son, born to die on a cruel cross.

At salvation, God welcomes us to his family and will never "kick us out" if we do wrong; but, he now has the rights of a father and disciplines us as His children. (1 John 1:6-9; Hebrews 12:6-10). Sometimes God has to get us back on the right track of fellowship with Him. He disciplines with love, which is not fun; but, for our own good. However, notice, we are still sons. We are still in the family.

The "feminist spiritualists" say this is too exclusive. They reject God as being in the male gender. They do not want God to be "parental or disciplinarian." So, I guess we should immediately throw out the prayer which begins "*Our Father which art in Heaven.*" They don't want a God that is "authoritarian." In other words, God's Holy Word is just a suggested lifestyle and God doesn't really mean what he says...right!

Also, we find in Romans 2:4 where even God extends His

*"...riches of his goodness and forbearance and longsuffering;
not knowing that the goodness of God leadeth thee to repentance*

"Repentance" here means a change of mind which results in trusting Jesus Christ as the only payment for sin, plus nothing!

As the context for this passage begins in Romans 1:18, we know these verses are addressed to those who are lost. A far cry from the accusations of the "feminist spiritualists" who accuse God of being unloving.

V. *Occult*

The feminists could not stomach God, as revealed in the Bible, His Holy Word. They have to have a God with "maternal" attributes such as nurturing, acceptance and creativity." The website refers to the Trinity as "Creator, Redeemer, Sustainer." That is vague enough to include anyone.

Hold on to your hat, now. Feminist belief systems draw heavily from Wiccan paganism (white witchery), Marxism and New Age; with a big focus on obtaining your "rights" as women by being "liberated" from all oppressive males, including God and everything He says in the Bible about women preachers, etc. This is what is being shoved off in this "shawl ministry." This is given away by the words from the shawl website, "with the giver and receiver feeling the unconditional embrace of a sheltering, mothering God."

Romans 1:25 pretty much describes their philosophy.

"Who changed the truth of God into a lie, and worshipped and served the creature more than the Creator, who is blessed for ever. Amen." (Romans 1:25)

I am going to try to sum this up. This is a Satanic delusion perpetrated upon unsuspecting women, probably in a time of sorrow or great need; and who sincerely want to do something for someone else. When you say something like what is said on their website, "When the shawl is completed, IT is offered a final ritual before being sent along its way;" this shawl has now become an IDOL, receiving ritual offerings. From their page about "Symbolism" they explain, so sweetly, that the Chinese, Mayan, Egyptians, Buddhists all accept their symbolism. In fact, almost any pagan religion recognizing shamans or "witch doctors" would accept it.

If you look hard enough, when they say "birth /death /rebirth (meaning life after death)" they are talking about reincarnation. If you believed in reincarnation, you would say, "This is for me"

In fact, as I read on and on, this is the worst kind of

V. Occult

paganism! They call it "dianic, or worship of the goddess, Diana, the huntress. Search the *Zondervan's Pictorial Dictionary* for a clue about how vulgar this is. It will show you what the statue of the goddess, Diana, of Ephesus looked like. You can read about her in the Bible in Acts 19:23-41.

I could go on and on; but, there is too much. I'll simply say, Christians should run from this mumbo jumbo! It is perpetrated by rebellious women who do not believe in the God of the Bible; or His words in the Bible; and are under the influence of Satan.

In Exodus 22:18, God forbade witchcraft with a death penalty. Now, I DO NOT mean to infer that we should kill witches; I am just showing how strongly God felt about this. (See also Deuteronomy 18:10).

Rebellious women were a downfall for Israel and surely prevalent in the world, and church today.

"As for my people, children are their oppressors, and women rule over them. O my people, they which lead thee cause thee to err and destroy the way of thy paths. The LORD standeth up to plead, and standeth to judge the people." (Isaiah 3:12,13)

Those who talk about "Feminist Spirituality" definitely don't believe God's Word in 1 Timothy 2:11,12.

"Let the woman learn in silence with all subjection. But I suffer not a woman to teach, nor to usurp authority over the man, but to be in silence.

I'll just close with this. Our precious Savior, the Lord Jesus Christ tells us in Hebrews 4:16,

"Let us therefore come boldly unto the throne of grace, that we may obtain mercy, and find grace to help in time of need."

Other good verses are Philippians 4:5-7, 13,19. I know these words will give you the most comfort in a time of grief or need. A shawl will keep you warm; but, God's word will give real *"help in time of need. "*

Why take Satan's counterfeit when you can have the real

V. *Occult*

thing, GOD'S WORD!

Isaiah's warning in Chapter 30, Verse 1,

“Woe to the rebellious children, saith the LORD, that take counsel, BUT not of me; and that COVER WITH A COVERING, but not of my spirit, that they may add sin to sin.” (Isaiah 30:1)

VI. Parables

1. *What Does The Parable of the Laborers Mean?*

Matthew 20:1-16

Question: Can you help me interpret the Parable of the Laborers in Matthew 20:1-16?

Answer: Parables are not given to build doctrine upon, but to illustrate spiritual and practical truths. Every parable has one main spiritual truth and some secondary applications. Do not make everything in a parable mean something, or you will get yourself lost.

The owner of the vineyard needed workers. In the morning (about 6 a.m.), these workers would not work until they knew exactly what they were going to get paid (Verse 2). In Verses 3,4 at the third hour (9 a.m.), the workers trusted the owner's promise of "*whatever is right I will give you.*" In Verses 5-7 the owner secured laborers about the sixth hour (noon), the ninth hour (3 p.m.) and the eleventh hour (5 p.m.) with the same promise. Those who started about 6 a.m. and worked all day would not have done so unless they were guaranteed a normal day's wage. Some Christians seem reluctant to go ahead and do things for the Lord unless they see a price tag of reimbursement before they start. It was their lack of faith that caused them to complain, as recorded in Verses 10,11,

"But when the first came, they supposed that they should have received more; and they likewise received every man a penny. (10) And when they had received it, they murmured against the good man of the house, " - Matthew 20:10-11

Personally, I want to serve the Lord because I love Him. I can honestly say, He has always, without exception, overpaid me much more than I deserve. I hope you feel the same.

"Therefore, my beloved brethren, be ye steadfast, unmoveable, always abounding in the work of the Lord, forasmuch as ye know that your labor is not in vain in the Lord". (1 Corinthians 15:58)

VI. Parables

2. *Why Was The Unprofitable Servant Cast Into Hell?*

Matthew 25:14-30 Vs. Ephesians 2:8,9

Question: In the parable of Matthew 25:14-30, why was the unprofitable servant cast into Hell? This seems to contradict Ephesians 2:8,9; that we saved from Hell, by grace through faith, without good works?

Answer: The Greek for "parable" is "parabola" and means "to lay along side of." It is given to illustrate a spiritual truth. In this parable, the unprofitable servant was a counterfeit Christian; just as Judas, who pretended to be a Christian; but was an impostor.

This is illustrated in the "Parable of the Sower" in Matthew 13:24-39. Good seed was sown; i.e. the Word of God, pictured in the wheat. Satan sowed his seed, the tares, which pictures the lost. (Verses 37-40).

Practically, in the local church there may be those who pretend to be Christians, but are not. Only the Lord knows as in 1 Samuel 16:7 we are told

"...for man looketh on the outside appearance, BUT the LORD looketh upon the heart."

People may fool people, but never the Lord. Therefore, Christ said in Matthew 13:30,

"Let both grow together until the harvest: and in the time of harvest (judgment) I will say to the reapers, Gather ye together first the tares (lost) and bind them in bundles to burn them (Hell): but gather the wheat (saved) into my barn (Kingdom)."

We may be fooled by people, but never by the Lord when He says,

"He that believeth on the Son hath everlasting life: and he that believeth not the Son shall not see life: but the wrath of God abideth on him." (John 3:36)

VII. Predestination, Foreknowledge, Election

1. *Is the World's Condition God's Fault?*

Question: If God created everything, then everything that happens is His fault. Since He created Satan, why can't he destroy him? God knew what sin I would commit before I existed. Why can't I point a finger at Him?

Answer: You're confusing God's foreknowledge with God's predestination.

*"For the Lord of hosts hath purposed, and who shall disannul it?
and his hand is stretched out, and who shall turn it back?"
(Isaiah 14:27)*

Just because God knows what is going to happen doesn't mean He causes it. God knows the things that would have happened if the things that did happen, didn't! God is omniscient, i.e., all-knowing.

(Read Ezekiel 28:12-19). God created Satan "perfect" (v. 15); until *"iniquity was found in thee."* God did not create Satan with flaws. He gave him a free will. Ezekiel 28:17 tells us how Satan exercised his free will. *"Thine heart was lifted up because of thy beauty.."* This is pride.

We see more of Satan's rebellious choices in Isaiah 14:12-17. *"For thou hast said in thine heart ... I will be like the most high."* Satan wanted God's very throne. He corrupted a third of the angels (now known as demons) to follow him. (Revelation 12:9,7-12). Satan *has been judged* (Genesis 3:15) and *will be destroyed*. The Lake of Fire was prepared for the Devil and his angels. (Matthew 25:41; Revelation 20:10).

When did this happen? In the dateless past, after the original creation (Genesis 1:1-2a). In the remodeling of the world in six days, as we know it now, Satan was already the evil character we know from Scripture. (Genesis 1:2b through Genesis 3:1; John 8:44).

VII. Predestination, Foreknowledge, & Election

God created man in innocence (untested righteousness) (Genesis 2:21,22), with a free will, the ability to choose God's will or his own. (Genesis 2:16,17). Of course, we know the "rest of the story," as it is given in Genesis 3:1-19. The Devil tempted Eve, she took the forbidden fruit *"of the tree of the knowledge of good and evil,"* and gave it to Adam. Physical and spiritual death entered the human race the moment Adam partook. They began to die *physically* through natural processes; though Adam lived to a ripe old age of 930 years (Genesis 5:5). God drove them out of Eden as, if they had eaten of the Tree of Life, they would have lived forever in this sinful state.

Adam and Eve died *spiritually*, as well (Romans 5:12). Their sinful nature separated them from God, and this they have passed on to the whole human race. *"For all have sinned"* in that we are descended from Adam and Eve. (Romans 3:23). Did God have a remedy for this great tragedy, the seeming ruination of his beautiful creation? Yes! Christ knew before the foundation of the world what His mission was to be. (1 Peter 1:18-20). He was to be the perfect sacrifice, the Savior of the world. (John 1:29).

Why? God wanted us to know His grace. (Romans 8:28-32).

"He that spared not his own Son, but delivered him up for us all, how shall he not with him also freely give us all things." (32)

All things! Everlasting life! God, the Holy Spirit living within us to help at all times! If He had made us just "robots"; we would have missed all this. We could never experience the graciousness of Almighty God.

Yes, God knew you before you were ever born (Psalm 103:8-14; Psalm 139:16). He knows all about you and He wants you to love and accept Him out of your own free will. Just as Satan, Adam and Eve had a free will; so do you.

"But as many as received him, to them gave he power to become the sons of God, even to them that believe on his name, Which were born, not of blood, nor of the will of the flesh, nor of the will of man, but of God. " (John 1:12,13).

VII. Predestination, Foreknowledge, & Election

2. *They Closed Their Own Eyes!*

Matthew 13:10-17, Mark 4:10-12; Luke 8:9-10; Isaiah 6:9-10

Question: Hi! I'm 12 years old. I live in Minnesota. I am using an NIV Bible and I have a question that is confusing to me. What do Matthew 13:10-17, Mark 4:10-12; Luke 8:9-10 & Isaiah 6:9-10 mean?

Answer: This is a great question for someone who is 12! The three New Testament passages you have quoted are parallel passages from the Synoptic Gospels. In other words, they are not different instances; but tell about the same thing. Matthew, Mark, Luke are the Synoptic Gospels. "Synoptic" means "view together." They all viewed the life and ministry of Christ; but each brought out different things. Put them all together and you get the total picture! That's the greatest proof these Gospels were inspired by God, we *know* they didn't copy from each other,

Of these three passages, Matthew is the most informative. I think what is troubling you is that you are thinking Christ was telling the disciples the "good stuff"; and withholding it from everyone else. This is not so. The people didn't really want to hear what He had to say. The answer is in Verse 15,

*"...their eyes **THEY** have closed, lest at any time they should see with their eyes and hear with their ears, and should understand..."*

Christ wanted to tell all the Jews that He was their Messiah, here to be crucified for sin, resurrected, AND set the Kingdom up that they had heard about for hundreds of years. John 1:11 tells us,

"He came unto his own, and his own received him not."

The Jews didn't want to hear it. Christ didn't hold anything back from them. They closed their own eyes and ears.

Matthew 13:16 says,

VII. Predestination, Foreknowledge, & Election

"...blessed are your eyes, for they shall see: and your ears, for they hear."

...not because they were better than everyone else; but because they WANTED to see and hear. If people want to do God's will, God will always see that they hear what it is. (John 7:16.17). Read about the Gentile, Cornelius, in Acts 10. He was a good man, but lost. He wanted to know how to be saved and God sent the Apostle Peter right to him.

Matthew 13:14,15 (and the others you ask about) are quoting the passage from Isaiah. This was a time in the history of the nation of Israel when they were doing the same thing as the Jews of Christ's day. God was having the prophet, Isaiah, tell them to "clean up their act"; or the Babylonians were going to come and there was going to be a 70-year captivity. Did they listen? No! They kept right on breaking God's laws of the Sabbath and sacrifice. In fact, God had sent many prophets to warn what would happen if they did this, even from the time of Moses. And, sure enough, the captivity happened! Since that time, Israel has not been the great nation she was before the captivity.

The Jews of Christ's day did not accept their Messiah; and, in 70 A.D., Titus and the Roman army came in and destroyed their beautiful city and temple. This is a good example of why we should always believe what God says.

I want to say that I do not recommend the NIV. Do you know it has 64,000 words missing? The King James Translation is, by far, the best we have today from the original manuscripts. I would suggest that you get a King James Translation to compare with when you use your NIV. The NIV is the worst imitation of a Bible; as many verses have been eliminated from it.

3. Does God Give Us the Faith to Believe With?

Question: I grew up in a church where I was taught that God gives you the faith to believe with for salvation. Is that the

VII. Predestination, Foreknowledge, & Election

meaning of Ephesians 2:8,9?

Answer: We will quote the verse you ask about,

"For by grace are ye saved through faith; and that not of yourselves: it is the gift of God: (8) Not of works, lest any man should boast." (Ephesians 2:8-9)

If this teaching were true, then God would be obligated to give everyone the faith to believe with. This would result in every human being trusting Christ as his Savior and inheriting eternal life. But, such is not the case. Therefore, if God gave only some the faith to believe with and not others, He would be an unjust God. Christ said that, *"God so loved the world,"* or every person (John 3:16), and Peter states in 2 Peter 3:9 that the Lord is *"...not willing that any should perish."* Paul, in writing to Timothy, states the Lord's will in 1 Timothy 2:4,

"Who will have all men to be saved, and to come unto the knowledge of the truth."

The teaching that God gives you the faith to believe with is a damnable, Satanic teaching which very cleverly brings in the false doctrine of predestination for salvation. Those who teach this; actually accuse the Lord of being guilty of the following:

(1.) Lying. When Peter, in 2 Peter 3:9 stated that God's will was that He was *"not willing any should perish,"* then God lied; since He didn't give everyone the faith to believe with when He could have; but He didn't. The truth is, the false teacher lied—not God.

"...Let God be true but every man a liar..." (Romans 3:4).

(2.) Prejudice. On what basis would God only give a few the faith to believe and let the rest spend eternity in Hell? Since Romans 3:23 tells us that,

"For all have sinned, and come short of the glory of God;"(i.e., His absolute perfection.)

Therefore, since all humanity is guilty of sin, God would be prejudiced if he gave the faith to believe with to only some, and

VII. Predestination, Foreknowledge, & Election

let all the rest perish.

(3.) Being A Respector of Persons. In Acts 10:34 we are told,

“Then Peter opened his mouth and said, Of a truth I perceive that God is no respector of persons.”

Yet, if God gave the faith to believe with to *some*, and not others; one could only conclude that God is a respector of persons. This false teaching is diametrically opposed to God’s Word in Acts 10:34. This false teaching also attacks the Holiness, Righteousness, and all the other Attributes of the character of God.

God does not “program” human beings to be robots. God has provided salvation for every person through the death, burial, and Resurrection of Jesus Christ in payment for our sins. Every person has his own free will with which to accept Christ; or reject Him, for their salvation.

Now, back to Ephesians 2:8,9.

(1.) *“For by grace are ye saved.”* Grace is God giving us what we do not deserve. That is, Christ paying for our sins, the “just for the unjust.” Mercy, on the other hand, is God withholding what we do deserve. We are only saved (i.e., from Hell), because of God’s grace in giving us what we do not deserve; by sending His Son to the cross in payment for our sins.

(2.) *“...through faith.”* It does not say “Through the faith God gives us.” Every false teaching has to add their philosophy to God’s Word. In Proverbs 30:6, God rebukes these false teachers for just that.

“Add thou not unto his words, lest he reprove thee, and thou be found a liar.”

(3.) *“And that not of ourselves.”* This is in reference to anything we, ourselves, do in order to merit eternal life. It may be joining a prominent church, attending every Sunday, teaching

VII. Predestination, Foreknowledge, & Election

Sunday School, being baptized and confirmed; or, changing our habits and leading an honest, moral life. But, none of these things we do ourselves, with our bodies, will ever merit eternal salvation. Titus 3:5b tells us that,

"Not by works of righteousness which we have done, but according to his mercy he saved us..."

Isaiah 64:6 makes it perfectly clear that,

"But we are all as an unclean thing, and all our righteousnesses are as filthy rags; and we all do fade as a leaf; and our iniquities, like the wind, have taken us away."

In other words, we place our faith in the merits of the cross, not in the merits of our own self-righteousness, which are nothing but filthy rags!

(4.) *"It is the gift of God."* Faith is not the gift of God; but, rather salvation is the gift of God to all that believe. Romans 6:23 tells us,

*"For the wages of sin is death; but **THE GIFT OF GOD IS ETERNAL LIFE** through Jesus Christ our Lord."*

NOT the gift of faith!

(5.) *"Not of works."* In Verse 9 we have the same thing as *"not of ourselves"* in Verse 8.

(6.) *"Lest any man should boast."* Since God is not willing any should perish; but that ALL should come to repentance (i.e. a change of mind), the invitation is that "whosoever will" may come. No! God does not give the faith to believe to some; and then go against His own will, and let the rest perish! When I, of my own volition, choose to put my faith in Jesus Christ as my Savior, I receive the gift of eternal life—free! Therefore, I have nothing of myself to boast about.

The last invitation in God's Word is found in Revelation 22:17, and is all-inclusive.

VII. Predestination, Foreknowledge, & Election

“And the Spirit and the bride say, Come. And let him that heareth say, Come. And let him that is athirst come. And WHOSOEVER WILL, let him take of the water of life freely.”

Remember—how could God justify Himself by letting any person go to Hell; when, He could have given him the faith to believe with, but didn't; and then say “I was not willing he should perish”? This is one of the results you end up with when you promote the false doctrine of predestination for salvation. How deceiving and misleading these false teachers are, who try to get you to believe that God gives you the "faith" to believe with!

*"It is better to trust in the Lord than to put confidence in man."
(Psalm 118:8).*

4. Does God Predestinate Only Some to Be Saved?

Matthew 20:16

Question: Does God predestinate only some to be saved. On what basis would He do this?

Answer: Matthew 20:16 is one of the verses most often used to support this false teaching.

“So the last shall be first, and the first last; for many be called, but few chosen.” (Matthew 20:16)

To understand this verse, we need to examine the context in which it appears, Matthew 20:1-16. So, let us go back to Verse One of this chapter.

“For the kingdom of heaven is like unto a man that is a householder which went out early in the morning to hire laborers into his vineyard.”

This is the “Parable of the Laborers in the Vineyard.” We need the context to find out why God said this and to what it is referring. It is not referring to salvation, as many try to apply it. In Verse 2, he (the householder) had gone out into the vineyard:

“And when he had agreed with the laborers for a penny a day, he sent them into his vineyard (i.e., to work)”

VII. Predestination, Foreknowledge, & Election

We find out that there were others that also went into the vineyard to work in Verse 7.

“They say unto him, Because no man hath hired us. He saith unto them, Go ye also into the vineyard; and whatsoever is right, that shall ye receive.”

Now, when it came to the end of the day, in Verse 10:

“But when the first came, they supposed that they should have received more; and they likewise received every man a penny.”

Notice carefully! Those who murmured had made a deal with the Lord (“*the good man of the house*”) to work for Him for a certain amount (Verse 2). God had simply kept His part of the bargain. They did not trust God to reward them honestly. What they actually did was limit the grace and goodness of God. God would have given them more; but, God gave them exactly what they had agreed to, and that was a penny a day. The others came freely, just trusting that the Lord would reward them accordingly, and he did. Then, we come on down and find out what the Lord said, at the conclusion of the Parable, in Verse 16.

“So the last shall be first, and the first last: for many be called, but few chosen.”

The Greek word for “called” is “invited or appointed to service.” The reason only a few were chosen for service is because of their attitude. Just as this Parable reveals—the first who came, came with the intent of making a deal with the Lord. Therefore, they did not receive the kind of reward for their labor that God would have given them, if they had not limited God by their dealings.

Therefore, the whole point of this Parable is, they are all invited (this being the “*many*” in Verse 16); BUT only those are “*chosen*” who come with the right attitude for service, trusting that God will reward them justly. This is the WHOLE point of the Parable. It concerns serving the Lord and has nothing to do with salvation whatsoever! Many are called, but only a few are chosen for His service depending upon their attitude toward

VII. Predestination, Foreknowledge, & Election

doing His service.

How important it is to examine the context of a Parable to determine if that Parable is speaking concerning salvation or service. Maybe if these false teachers would, as 2 Timothy 2:15 admonishes one to do,

*“Study to shew thyself approved unto God, a workman that needeth not to be ashamed, rightly dividing the word of truth, and, therefore teach the truth,
“That he (Christ) by the grace of God should taste death for every man” (Hebrews 2:9c)*

Why would Christ taste death for every man, if every man did not have the opportunity to be saved?

5. Please Define "Predestination" in Ephesians 1:5

Question: Would you explain Ephesians 1:5 concerning the meaning of the word “predestination.

Answer: The word "predestination" comes from the Greek verb "proorizo." It means, according to *Vine's Expository Words on the Greek New Testament*, to "mark out beforehand, to determine before, foreordain." In essence, "predestination" means that something has been predicted by God and it must and will come to pass. The word "predestinate" as translated in the KJV is found only twice; that being in Romans 8:29 and 30. "Predestinated is found only twice and that is in Ephesians; once in Ephesians 1:5 and once in 1:11. These two words do not appear in the Old Testament. We shall examine WHO is predestinated, WHAT event is predestined and WHEN it will take place.

A. Let us begin with Ephesians 1:5.

“Having predestinated us unto the adoption of children by Jesus Christ to Himself, according to the good pleasure of his will.”

Notice who is predestinated. It can only be one of two groups. The saved or the lost. Paul identifies the children of God

VII. Predestination, Foreknowledge, & Election

as the object of being predestinated, "*Having predestinated us* (plural pronoun)." This is Paul and every saved person. God did not predestinate anyone to be saved; but this teaches He predestinated something for those who are already saved.

What did God predestinate for the Christian? The Scriptures are pure and simple. The Christian is predestinated unto the adoption of children (Greek, HUIOTHESIA, meaning sonship). When we trust Christ as our Savior, we become His children:

"But as many as received him, to them gave he power to become the sons (Greek, teknon, meaning—"a child") of God, even to them that believe on his name." (John 1:12).

When? We are positioned in Heaven as a son now; but we do not come to the realization of our Sonship until the Rapture.

The Jewish Bar Mitzvah may aid in understanding adoption and Sonship. Bar Mitzvah means "a son of the commandments, or the placing of a son." When a Jewish boy reaches the age of 13, he is then considered as an adult. He is expected to accept adult religious responsibilities. It is a joyful occasion accompanied by gifts from friends and family. He is no longer considered a child; but an adult son.

The word "adoption" is from the Greek word "huiiothesia," from "huios;" meaning "a son," and "thesis," "a placing." Therefore..."the placing of a son." Just as a Jewish boy is placed as an adult son on the day he reaches 13, we Christians also experience our Sonship when we are placed in Heaven at the day of the Rapture. This is when we have our physical bodies redeemed for a new glorified body. It could be no clearer than stated in Romans 8:23:

"And not only they, but ourselves also, which have the first fruits of the Spirit, even we ourselves groan within ourselves, WAITING FOR THE ADOPTION, TO WIT, THE REDEMPTION OF OUR BODY."

IN SUMMARY:

VII. Predestination, Foreknowledge, & Election

WHO: Negative: nowhere are the lost said to be predestinated to be saved

WHAT: Positive: the saved are predestinated to receive something.

WHEN: At the Rapture. 1 Thessalonians 4:17, 1 Corinthians 15:50-54.

The false teaching of predestination for salvation is nothing more than a subtle, Satanic attack against God's character. John 3:16 says that,

"For God so loved the WORLD, that he gave his only begotten Son, that WHOSOEVER, believeth in him should not perish, but have everlasting life."

How could God love the world and then pick only a few to predestinate to salvation and let the rest go to Hell? Christ's death and Resurrection paid for the sins of all humanity and whosoever believeth in him has everlasting life!

6. Please Define "Predestination" in Ephesians 1:11,12?

Question: What is your explanation of Ephesians 1:11,12 concerning the word "predestinated?"

Answer: Let us quote the text in its entirety.

"In whom we have obtained an inheritance, being predestinated according to the purpose of him who worketh all things after the counsel of his own will: (11) That we should be to the praise of his glory, who first trusted in Christ." (Ephesians 1:11,12)

Notice the use, in Verse 11, of the word "we," a plural pronoun. Paul is including himself with all Christians. They all have obtained an inheritance. This identifies those who are predestinated for a certain result, as being already saved. We can see in Verse 12 what the Christian is predestinated to receive.

Verse 11 also tells us that what is predestinated is according to the Lord's purpose. He will also bring it to pass "...after the

VII. Predestination, Foreknowledge, & Election

counsel of his own will:" *"His own will"* lets us know that God does not leave what He has predestinated to be brought to pass by the volition, or faithfulness, of man. Therefore, we can rest assured; what God predestinated will come to pass!

In summary: The saved are the recipients of what is being predestinated. It was God's purpose to do so, and He will bring it to pass Himself. We are told in verse 12 what is predestinated:

"That we (Christians) should be to the praise of his glory, who first trusted in Christ.

At first glance one may think this means it is God's will that every Christian should lead a separated life, which would be "*to the praise of his glory.*" This is certainly God's will for every believer. (Romans 12:1,2). However, this cannot be the meaning of this verse, if taken in context, as the fulfillment of what was predestinated. If this were true, then it has not come to pass in every Christian's life. Remember, what God predestinates will, without exception, come to pass. The reason being, every Christian is the recipient of what is predestinated; but, not every Christian leads a separated life. In fact, some Christians never lead a separated life from the time they are saved until they leave this earth!

To what is this referring? It has reference to the event of the Rapture when, without exception, every Christian will be "*to the praise of his glory.*" Here are two results of the Rapture:

"Who shall change our vile body, that it may be fashioned like unto his glorious body, according to the working whereby he is able even to subdue all things unto himself." (Philippians 3:21)

"Beloved, now are we the sons of God, and it doth not yet appear what we shall be: but we know that, when he shall appear, we shall be like him; for we shall see him as he is." (1 John 3:2)

The Bridegroom (Christ) is looking in expectation for His Bride (the Church). The Church (every believer) is looking for the Bridegroom to return; and so shall we ever be with the Lord. This meeting is the fulfillment of what Christ predestinated for

VII. Predestination, Foreknowledge, & Election

every believer; that, we will be *"to the praise of his glory."* Remember—what is predestinated must come to pass.

If *"to the praise of his glory"* meant leading a separated life, it may not come to pass; for all Christians are not yielding their lives to God's will. Christ never leaves what He predestinates to be fulfilled by the volition of man. By the determined will and power of God, the Rapture will fulfill every qualifying aspect of His predestination, *"that we should be to the praise of His glory."*

7. *What Is the Meaning of the Word "Predestination" In Romans 8:29?*

Question: How do you explain "predestinate" in Romans 8:29?

"For whom he did foreknow, he also did predestinate to be conformed to the image of his Son, that he might be the firstborn among many brethren." (Romans 8:29).

Answer: The statement is heard many times that, "You cannot reconcile the sovereignty of God and the free will of man." This is not true—one can understand both. The confusion exists when one does not properly understand the meaning of foreknowledge and predestination. Foreknowledge is an attribute of God's omniscience. Primarily, foreknowledge has to do with persons and places, and predestination is centered in God's purposes.

Foreknowledge contains one element, that is, knowing what is going to happen before it takes place. In relation to people and places, it does not contain the element of bringing it to pass or making it happen.

Predestination, on the other hand, is different from foreknowledge in that it contains two elements: One is the prediction (His omniscience), and the other is the act of God (His omnipotence) to bring it to pass. The confusion begins when one inserts meanings into a word which it does not contain.

VII. Predestination, Foreknowledge, & Election

Remember, keep these two words separated as to their meaning.

Foreknowledge has one element, that of foreknowing what is going to happen. Do not add any other meanings to this word, it contains one element only!

Predestination has two elements; one is predicting, the other is fulfilling. Again, predestination is related to God's purposes, foreknowledge is related to persons and places.

In verse 29 we are told:

"For whom he (Christ) did foreknow..."

This simply states that Christ knew, ahead of time, every person who would trust Him as their Savior. The word carries no other element which would impede the free will of a person to make his, or her, own choice. Every Christian who will be saved is foreknown of God. We also see that every Christian is going to be the recipient of what God is going to predestinate.

"For whom he did foreknow (every Christian) He also did predestinate. ..."

He foreknew every person who would be saved. His purpose is seen in predestination, as we are predestinated to what?

"...To be conformed to the image of his son,..."

When will we be conformed to the image of God's Son? At the Rapture, of course!

In Philippians 3:20,21 we are told:

"For our conversation (citizenship) is in heaven; from whence also we look for the Saviour, the Lord Jesus Christ. (20) Who shall change our vile body, that it may be fashioned like unto his glorious body."(21)

This is being "conformed to the image of His Son." This is also what is meant by Ephesians 1:12, "to the praise of his glory."

In 1 John 3:2 we read:

VII. Predestination, Foreknowledge, & Election

"Beloved, now are we the sons (Greek, TEKNON, "children") of God, and it doth not yet appear what we shall be: but we know that, when he shall appear (at the Rapture) WE SHALL BE LIKE HIM; for we shall see him as he is."

Predestination becomes very clear if we do three things: One, take exactly what the Scripture says and believe it. Two, know the difference between foreknowledge and predestination; and, Three, add no other elements of meaning to them. Foreknowledge has one element while predestination has two.

In summary: Romans 8:29 teaches the following according to predestination:

WHO: Only the saved are predestinated, never the lost to be saved.

WHAT: Christians are predestinated at some future time to *"be conformed to the image of his Son."*

WHEN: At the Rapture. Philippians 3:20,21, 1 John 3:2

Those who claim that God predestinated some to be saved, while letting the others go to Hell, are accusing God of being a liar. As we look at the word of God, may we let the Lord defend Himself against these false teachers. In John 3:16 God says He *"loved THE WORLD."* In 2 Peter 3:9, the Lord says He is, *"not willing that any should perish; but that all should come to repentance."* (i.e., Greek, metanoia; "a change of mind.")

Therefore God's word makes the predestinationalists out to be liars; but, not the Lord! Hebrews 6:18 says it is "...impossible for God to lie,..." Remember, the middle verse of the Bible is Psalm 118:8,

"It is better to trust in the LORD than to put confidence in man."

8. *When Did God Begin to Hate Esau, as in Romans 9:13?*

Question: Greetings, Dr. Younce. I am a true believer in our Lord Jesus Christ. I believe that God wants ALL to choose Him; however, He gives us the choice. And, from what I have read and

VII. Predestination, Foreknowledge, & Election

understand, God predestined that ANYONE who chooses Jesus as his Savior will be adopted (made a child of God), with all the benefits. I am trying to convince a good friend that may be headed down the wrong trail. He confuses the usual ideas about predestination, and his big quote is "Jacob I love, but Esau I hate."

Answer: We shall begin by quoting Romans 9:13,

"As it is written, Jacob have I loved, but Esau have I hated."

God never chooses anyone for salvation. He *does* "choose" or "elect" individuals, or even whole nations, to perform certain tasks or services for Him.

As it is never correct to take Scripture out of context (2 Peter 1:20), we will begin with the context of this verse, which begins in Romans 9:7 and continues through to Verse 13.

"Neither, because they are the seed of Abraham, are they all children: but, In Isaac shall thy seed be called. (7) That is, They which are the children of the flesh, these are not the children of God: but the children of the promise are counted for the seed. (8) For this is the word of promise, At this time will I come and Sarah shall have a son. (9) And not only this; but when Rebecca also had conceived by one, even by our father Isaac; (10) (For the children being not yet born, neither having done any good or evil, that the purpose of God according to election might stand, not of works, but of him that calleth;) (11) It was said unto her, the elder shall serve the younger. (12) As it is written, Jacob have I loved, but Esau have I hated." (Romans 9:7-13).

As we read these verses we find out that God was electing or choosing, by "selective breeding," a nation for Himself. Even though within that nation, not everyone would be looking for the coming of Christ. In other words, He was selectively breeding a people that would be known as the nation of Israel.

God exercised His own choice as to who would be the father of the nation. When it came to the promise to Abraham and Sarah, God had promised them a son. Of the children they were to have, God would choose through which one the seed and the

VII. Predestination, Foreknowledge, & Election

promise should come. God promised the seed by Abraham and Sarah in Genesis 15:3,4. Too impatient to wait on God's promise, Abraham went in unto Hagar, who was Sarah's Egyptian handmaid. She conceived and bore a son by the name of Ishmael; but, this was not the promised seed through which the nation of Israel should be born.

We find out that later, at a very old age (Abraham being 100 years old and Sarah being 90), that God fulfilled His promise and Isaac was born. (Genesis 21:1-5) We find that God had said:

"But my covenant will I establish with Isaac..." (Genesis 17:21)

God had selected him. This has nothing to do with the salvation of Isaac!

As we continue, we find that Isaac married Rebekah and they had two sons, Jacob and Esau. If you will notice carefully, God had said: *"...the elder shall serve the younger."*

We find this in Genesis 25:23. This was only to establish the birthright, and the ancestral headship, of the nation; and had absolutely nothing to do with Esau's salvation! God had the right to choose through which individual the nation of Israel would be born. But, because of that, it does not mean that Esau could not have been saved. In fact, this leads us to the very next point. Those who say you are chosen to salvation, miss the point of this passage altogether.

*"As it is written, Jacob have I loved, but Esau have I hated."
(Romans 9:13).*

Notice carefully, the Bible says *"As it is written..."* Where do you find this written? Turn with me to Malachi 1:1-3, and this is where it is written. This was not written before Jacob and Esau were born! God did not elect one to be saved; and the other to be lost. He did not say *"Jacob have I loved, but Esau have I hated."* prior to Jacob and Esau's birth. This was said some 1500 years later, after Esau had chosen to practice his evil acts. Then God

VII. Predestination, Foreknowledge, & Election

said, "*Jacob have I loved, but Esau have I hated.*" Remember—this was not done before they were born! It was not God's will to hate Esau before he was ever born! He only chose Jacob as the seed through which the Messiah would come; and, as an ancestral head in building the lineage of the nation of Israel.

Let us read in Malachi 1:1-3

"The burden of the word of the Lord to Israel by Malachi. (1) I have loved you, saith the LORD. Yet ye say, wherein hast thou loved us? Was not Esau Jacob's brother? saith the LORD: yet I loved Jacob. (2) And I hated Esau, and laid his mountains waste for the dragons of the wilderness of the wilderness." (3)

Notice carefully that God had already done what He had said in Malachi. But, this was done only after Esau had practiced the evil things, and despised his heritage. Most certainly did God do what He said! But God did not say this before Esau was born; nor does it relate to his salvation. God has said to us before we were born:

"For God so loved the world, that he gave his only begotten Son, that whosoever believeth in him should not perish, but have everlasting life." (John 3:16)

But after we reject Christ in this life; God hates all workers of iniquity. He most assuredly does! But, then, we are going to find out that God will honor our choice.

It is your choice. Whether you accept or reject Christ, God will honor that choice. If you choose to reject Christ, you will spend eternity in the lake of fire. (Matthew 25:41). If you choose to accept Christ, you will be "...passed from death unto life." (John 5:24). But it is your choice, because God is "*not willing that any should perish.*" (2 Peter 3:9).

Another thing we might notice here is, that while this portion of Scripture occurs in the New Testament, it was written almost 400 years after Malachi's words. So there are actually about 1500 years between Verse 12 and Verse 13 of Romans, Chapter 9. How important it is to take time and to study these

VII. Predestination, Foreknowledge, & Election

Scriptures pertaining to Esau!

I will pray for you in your quest to win your friend to believe that Jesus Christ paid the price for the sin of the WORLD on Calvary. God did not choose some to go to Heaven and some to go to Hell. God said He loved the WORLD, and Jesus Christ came to pay for the sin of the WORLD, and WHOSOEVER believes that, has everlasting life. (John 3:16; Ephesians 2:8,9; 1 John 5:13).

9. *Did Christ Predestinate Some to Salvation & Not Others?*

Romans 8:30

Question: Does Romans 8:30 mean that Christ predestinated some to salvation, and not others? This would contradict John 3:16 that says; “*God so loved the WORLD.*” Please explain.

Answer: We shall begin by quoting the verse in question:

“Moreover whom He (Christ) did predestinate, them he also called: and whom he called, them he also justified: and whom he justified, them he also glorified.” (Romans 8:30.)

Let us briefly examine each aspect of this verse as we observe the simplicity of God's Word.

“Moreover whom He did predestinate.”

As we have found, those who are predestinated are only the Christians, never the lost to be saved.

“...them he called...”

How are Christians called? In Romans 10:17 we are told that:

“So then faith cometh by hearing, and hearing by the word of God.”

And we are told in John 6:44:

“No man can come to me, except the father which hath sent me draw him:...”

This verse is comparable to that of Romans 8:30. The

VII. Predestination, Foreknowledge, & Election

phrases "*them he also called*" and "*draw him*" lead us to ask, "How, then, does God draw or call the lost?" In John 12:32 we have the Answer:

"And I, if I (Christ) be lifted up from the earth, will draw all men unto me."

"All men" here does not mean "all men without exception"; but, "all men without distinction of race, creed, social standing, etc."

We are called, or "drawn," by the Word of God which testifies of the Resurrection and Ascension of our Lord. So then, if "*faith cometh by hearing, and hearing by the Word of God*" (Romans 10:17), Christ will draw men by the hearing of the Word. This is the preaching of the gospel:

"Moreover, brethren, I declare unto you the gospel which I preached unto you,...how that Christ died for our sins according to the scriptures; and that he was buried, and that he arose again the third day according to the scriptures." (1 Corinthians 15:1,3b,4).

Christ never calls us outside of His Word. (Romans 10:17.) The called are those who have believed His Word, by accepting Christ as their personal Savior.

"... them he also justified..."(8:30b)

All are declared righteous upon receiving Christ by faith. As it says in Romans 5:1,

"Therefore being justified (declared righteous) by faith, we have peace with God through our Lord Jesus Christ:"

And...

"...them he also glorified." (8:30c)

Notice the use of past tense here. This is a positional truth. God looks upon Christians as though they were already in Heaven. (Notice the past tense of Ephesians 2:6.)

In summary: Romans 8:30 simply teaches that the ones who were the object of God's predestination were already saved; for "whom he did predestinate," these are the "called, justified, and

VII. Predestination, Foreknowledge, & Election

glorified."

No one is ever predestinated to be saved. You must, personally, realize you have sinned and come short of the glory of God (Romans 3:23). God sent Christ to pay for our sin (2 Corinthians 5:21); so we do not have to pay that debt ourselves in Hell. If one will only believe in (trust) Jesus Christ as his Savior, God will give him eternal life.

"These things have I written unto you that believe on the name of the Son of God; that ye may know that ye have eternal life, and that ye may believe on the name of the Son of God." (1 John 5:13).

It should be recognized that all of the Old Testament prophecies could be stated as being predestinated. Other words synonymous with "predestinate" would be "foretelling, prophesy, predicting and etc." For God to predict the future of people, places and nations, he would have to foreknow the future.

We are grateful to God for His precious Word. There are thousands of prophecies where synonymous words are used instead of "predestinate." I have limited our study only to the four places where the actual word appears in the Bible—due to its misuse! Expanding any further into prophecy would constitute a book, or books, on that great subject!

10. Who Hardened Pharaoh's Heart?

Question: I am reading Romans 9:17. Who hardened the Pharaoh's heart? God? Or, Pharaoh?

Answer: Many great Bible truths are found in Romans, Chapter Nine; but, as we have seen, many stray from God's grace by misinterpreting this wonderful chapter in God's Word.

We shall begin by quoting the verse in question, Romans 9:17, where Pharaoh is used as an illustration.

"For the scripture saith unto Pharaoh, Even for this same purpose have I raised thee up, that I might shew my power in

VII. Predestination, Foreknowledge, & Election

thee, and that my name might be declared throughout all the earth."

We pick up the record of Pharaoh back in the first few chapters in Exodus. We are going to find out that Pharaoh was a very wicked man, who had already hardened his heart many, many years toward the nation of Israel. God also had raised this man up, no doubt, and given him the position that he had. This did not mean when the Scriptures say "raise him up" that this man did not have a free choice, because he did. You will find that the Bible says that God sets one up in authority and takes down another. (Psalm 75:6,7 and Daniel 2:21)

"And he changeth the times and the seasons: he removeth kings, and setteth up kings: he giveth wisdom unto the wise, and knowledge to them that know understanding." (Daniel 2:21)

You see, God had worked the circumstances out so *this* Pharaoh would be the king of the nation of Egypt. But, Pharaoh's choice as to whether he would harden his heart, or not, was entirely up to him.

This man had already hardened his heart many times against the nation of Israel. Israel had made the bricks and gathered their own straw at Pharaoh's command. (Exodus 5:8-11) Pharaoh had set the taskmasters over Israel. (Exodus 1:11). The Israelites were slaves in the land, at the hand of this Pharaoh. He was a very evil, wicked man who had already hardened his heart. Then it came time for God to lead the nation of Israel out from the bondage of Egypt by the hand of Moses, His servant. Moses, therefore, went unto Pharaoh to carry out the demands that God had made concerning this and challenged Pharaoh. The beginning of the record is found in Exodus 5:1,2:

"And afterward Moses and Aaron went in, and told Pharaoh, Thus saith the Lord God of Israel, Let my people go, that they may hold a feast unto me in the wilderness.

"And Pharaoh said, Who is the Lord, that I should obey his voice to let Israel go? I know not the Lord, neither will I let Israel go."

Then we find in Exodus 4:21:

VII. Predestination, Foreknowledge, & Election

"And the Lord said unto Moses, When thou goest to return unto Egypt, see that thou do all those wonders before Pharaoh, which I have put in thine hand: but I will harden his heart, that he shall not let the people go."

This has confused many, many Christians. They say, "Well, God had hardened Pharaoh's heart. Does that mean he did not have a free will as far as letting the people of Israel go?" No, not at all. We find out that Pharaoh hardened his own heart and that God also hardened his heart; only by forcing Pharaoh to openly declare his decision. This was done in response to God's command, "*Let my people go.*"

We know Pharaoh's heart concerning his treatment of Israel; but, we did not know his heart was hardened concerning the freedom of Israel from bondage. God hardened his heart only in the sense of forcing him to make a decision in this matter. Then, his heart was hardened only because of the word of God that had confronted him. In that sense, God hardened Pharaoh's heart concerning this decision of letting Israel go. The hardening of Pharaoh's heart in Romans 9 was concerning letting the nation of Israel out of bondage from the land of Egypt.

God simply pressed the matter to a conclusion and forced Pharaoh to make a decision. In that manner God hardened Pharaoh's heart; or made Pharaoh openly declare his refusal to obey God's command.

We come now to Exodus 8:15:

"But when Pharaoh saw that there was respite, he hardened his heart, and hearkened not unto them, as the Lord had said."

We find that Pharaoh had hardened his heart again. This is in response to Exodus 8:5,12-15:

*"And the Lord spake unto Moses, Say unto Aaron, Stretch forth thine hand with thy rod over the streams, over the rivers, and over the ponds, and cause frogs to come up upon the land of Egypt. (5)
"And Moses and Aaron went out from Pharaoh: and Moses cried unto the Lord because of the frogs which he had brought against Pharaoh. (12)*

VII. Predestination, Foreknowledge, & Election

And the Lord did according to the word of Moses; and the frogs died out of the houses; out of the villages, and out of the fields.

(13)

And they gathered them together upon heaps: and the land stank

(14)

But when Pharaoh saw that there was respite, he hardened his heart, and hearkened not unto them; as the Lord had said." (15)

Here we find out from Verse 15, that Pharaoh hardened his own heart. It was only in the respect that God forced him to make a decision; that God hardened Pharaoh's heart in Exodus 7:13. God just pushed the matter to a conclusion. The free will was Pharaoh's!

Mr. Nettleton, in his book "Chosen to Salvation" published by Regular Baptist Press, uses these verses to support his position concerning election on pages 30 and 31. He neglected to take his readers back to Exodus and show them what Romans was referring to, when quoting this man as an example. Pharaoh surely fulfills Proverbs 29:1 where we are told:

"He, that being often reprov'd hardeneth his neck, shall suddenly be destroyed, and that without remedy."

In Ecclesiastes 9:12 we are told:

"For man also knoweth not his time: as the fishes that are taken in an evil net, and as the birds that are caught in the snare; so are the sons of men snared in an evil time, when it falleth suddenly upon them."

This is exactly what happened to Pharaoh when he pursued the nation of Israel into the Red Sea, and God drowned him there along with his whole army. He surely had no idea that the time had come when God would render His judgment. He was surely a "vessel fitted to destruction" and a "vessel of wrath." God did not make him that way. He, of his own free will, paid the ultimate price for refusing to obey the Lord!

If Pharaoh had no free will, you end up with this conclusion—God ordered Pharaoh to free the nation of Israel, while at the same time preventing him from doing so. Why

VII. Predestination, Foreknowledge, & Election

would God ask Pharaoh to do something He had no intention of letting him do? This false doctrine makes the God I worship, a God of confusion. No! The confusion is the product of false doctrine and those that put it forth; and, is not caused by God.

When God commanded Pharaoh to do something, God extended to him the free will to obey or disobey. No! God is not some demented, deranged, psychological being; saying one thing and doing another. He is omniscient, omnipotent, and His acts and actions are in accordance with His word, the Bible; and His attributes.

God raised Pharaoh up and demonstrated that He was more powerful than even the mighty king of Egypt! But Pharaoh did have a choice. He could have been saved. God loved him; but he hardened his own heart, refusing obedience to God. The power of God, and the wrath of God, was shown to be mightier than even this great king. He not only did that to show His wrath upon "the vessel fitted to destruction"; but, He also showed proof to the nation of Israel that no man, no matter what position he held, could ever stand under the hand of God Almighty!

It was an encouragement to the nation of Israel, showing them that whatever they faced in the land of Canaan, God could overthrow it. If God could destroy the mighty king of Egypt; then they could trust Him to destroy any other king they might face on their march to the land God had graciously promised Abraham, Isaac and Jacob.

Let us go on and examine Romans 9:20,21.

"Nay, but, O man, who art thou that repliest against God? Shall the thing formed say to him that formed it, Why hast thou made me thus?"

Hath not the potter power over the clay, of the same lump to make one vessel unto honour, and another unto dishonour?"

One must simply remember that God has the right to place any person in the place of honor in the eyes of men; without

VII. Predestination, Foreknowledge, & Election

explaining to us the reason. Many times God does tell us His reason for doing so; as He did concerning Pharaoh in Romans 9:17:

"For the scripture saith unto Pharaoh, Even for this same purpose have I raised thee up, that I might shew my power in thee, and that my name might be declared throughout all the earth."

Again, may I remind our readers that this has nothing to do with the salvation that God has offered by His grace to everyone.

Notice in Psalm 75:6,7 where God says:

"For promotion cometh neither from the east, nor from the west, nor from the south. But God is the judge: he putteth down one and setteth up another."

We find that God does raise up certain ones to a position of honor, even if they are lost. He raised up Pharaoh of Egypt, Nebuchadnezzar of the Babylonians, Alexander the Great of the Grecian Empire, Cyrus of the Persian Empire, Antiochus Epiphanes, even Herod the Great. He put these men in places of position and power; and did show His mercy unto these men, even while they hated Him for such a long time. God was not obligated to do so, but He did. God could have killed them at any time; but did extend His mercy to those who were fitted for destruction. This is just simply God running things the way He wants to run them.

God has determined the 1,000-year Reign of Christ. Who determined that? God did. He has prepared the Lake of Fire for the Devil and his angels. Things of this sort are things that God has planned. This is God exercising His omniscience and omnipotence concerning His dealings with his Creation.

When it comes to God's creation, God says He loved the *world!* And the fact is, when He says He loves the world; He *means* He loved the *world!* He gave His only begotten Son that *whosoever*, the whosoever goes along with the personal responsibility of everyone; and it corresponds with God's loving

VII. Predestination, Foreknowledge, & Election

everyone. He gave His Son for everyone, not just the elect. Therefore, anyone “*who wills*” may come to Christ; believing that He died to pay for their sins, and God will give to them eternal life. This is God's will for all. God would have to go against His own will, if election to salvation were true. This would be absolutely impossible!

"That by two immutable things, in which it was impossible for God to lie, we might have a strong consolation, who have fled for refuge to lay hold upon the hope set before us:(18) Which hope we have as an anchor of the soul, both sure and stedfast,..." (19b) (Hebrews 6:18, 19b)

VIII. Prophecy

1. *Who Is The Rider on a White Horse?*

Revelation 6:2

Question: In Revelation, Chapters 6 and 19, there is a rider on a white horse. Are they the same person?

Answer: No, they are not. In Revelation 6:2, we read,

"And I saw, and behold a white horse; and he that sat on him had a BOW; and a crown was given unto him: and he went forth conquering and to conquer."

This rider is none other than Satan, the Antichrist. In Revelation 19, the rider is the Lord Jesus Christ. Notice how the deceitful character of Satan is described in 2 Corinthians 11:14,15,

"And no marvel; for Satan himself is transformed into an angel of light. Therefore it is no great thing if his ministers also be transformed as the ministers of righteousness; whose end shall be according to their works."

Notice how Satan counterfeits the Lord Jesus Christ in Revelation 6:2.

1. He rides a white horse. So does Christ.
2. He has a bow, but no arrows. He comes as a false peace-maker; whereas Christ is the Prince of Peace.
3. He professes to be God. (2 Thessalonians 2:4).
4. He is a murderer and a liar in John 8:44; but pretends to be an angel of light. Christ is the true light of the world and John 14:6 says,

"...I am the way, the truth (not a liar), and the life (not a murderer): no man cometh unto the father but by me."

5. In 2 Corinthians 4:4, Satan is spoken of as the "*god of this world*" and "*blinding*" as many as he can from believing the Gospel of Christ.

VIII. Prophecy

Satan wants you to believe that by being a good person and doing the best you can, you will deserve Heaven. God says in Ephesians 2:8,9,

"For by grace are ye saved (from Hell) through FAITH; and that not of YOURSELVES: it is the gift of God: NOT OF WORKS, least any man should boast."

Who are you going to believe, Satan or Christ?

2. *Did God Predict That We Would Have Television?*

Daniel 12:4; Revelation 11:9

Question: In Daniel 12:4, the Bible says that knowledge shall be greatly increased. Did God ever predict that we would have television?

Answer: Yes, our omniscient God did predict the whole world would see certain events that He prophesied would happen. He did not say by what means the whole world would see it, only that it would.

For example: three and a half years after the Rapture, in the middle of the 7-year Tribulation, the two witnesses are put to death by the Antichrist. Their bodies are not buried, but put on display for 3 and a half days and the whole world will see it. God's word tells us in Revelation 11:9

"And they of the people and kindreds and tongues and nations shall SEE their dead bodies three days and an half, and shall not suffer their dead bodies to be put in graves."

Before satellite TV this would have been impossible; but, now the whole world will see this event just as God had predicted almost 2,000 years ago.

God has also predicted in 1 John 5:13 that

"These things have I written unto you that BELIEVE on the name of the Son of God (Jesus Christ); that ye may know that ye have eternal life..."

VIII. Prophecy

3. *Is Gog & Magog Russia & Why Does She Attack Israel?*

Ezekiel 38,39

Question: I have heard that Gog and Magog have something to do with prophecy concerning the nation of Israel? Why do they attack Israel?

Answer: Due to the myriads of questions about Russia's place in prophecy and the interest shown, we will cover this topic with a series, as covered in Ezekiel 38, 39.

Who is Russia? In Ezekiel 38:2 we read,

"Son of man, set thy face against Gog, the land of Magog, the chief prince of Meshech and Tubal, and prophesy against him ".

1. The Bible Encyclopedia says they are the furthestmost, northern nations dwelling in the regions of the Caucasus Mountains and the Volga River in Russia.

2. The great Jewish historian, Josephus, in Book One, Chapter Six, says the Scythians were called "Magog".

3. The word "chief" in Verse 2 is the Hebrew "rosh," which is also the Swedish name for Russia.

4. "Meshech" is identified as present day Moscow, representing the western part of Russia."Tubal" is present day Tobolsk, one of the chief cities representing the eastern part of Russia.

5. Ezekiel 38:15 and 39:2 tell us that Russia will come from the "*north parts*" to invade Israel. In Bible prophecy, the directions north, south, east, and west are figured from Palestine and Jerusalem as the center. This is biblically speaking. Check your world map and you will find the latitude line runs almost directly north from Jerusalem to Moscow.

No one could have known 2,600 years ago that the mighty nation of Russia would be existing today, except the omniscient, almighty God. Ezekiel was only "the pen" which wrote the mind of God concerning the future for "*All scripture is given by the*

VIII. Prophecy

inspiration of God." (i.e. God-breathed). (2 Timothy 3:16).

God has also prophesied the future of all mankind in John 3:36.

"...He that believeth not the Son shall not see life; but the wrath of God abideth on him. "

4. *Who Will Be Russia's Allies?*

Ezekiel 38:5,6

In Ezekiel 38:5,6, five allies of Russia are given. We will examine them separately.

1. Togarmah. From History and ancient Geography we learn that Togarmah was ancient Armenia (Asia Minor). This area is now known as modern Turkey. In 1975, Turkey deported our military from its borders and closed 20 of our air bases. Prior to this, Turkey had opened the Dardanelles, allowing the Russian fleet to sail out of the Black Sea into the Mediterranean Sea. Her ships were then in the Mediterranean for the first time since 1918. In 1975, Russia matched the U.S. fleet ship for ship; and now, in spite of the reverses suffered in the break up of the former Soviet Union, Russia is still a force to be reckoned with. During the Gulf War and the conflict with Kosovo, the U.S. and NATO had to beg for *some* use of Turkish airbases. Turkey will be with Russia when she invades Israel.

2. Persia. In 1935, Persia changed her name to Iran. She has always been associated with Russia, except during the reign of the Shah. The Shah endorsed Christianity and was a friend to the United States. We poured millions of dollars into this country. After the Shah was disposed of, Iran again showed her favoritism toward Russia. Yes, Persia (Iran) is leaning heavily toward Russia and will be with Russia when she invades Israel at the beginning of the Tribulation.

Back in 1979, a friend of mine was speaking on prophecy at a Bible conference in St. Petersburg, Florida. After the service a

VIII. Prophecy

man came to him and introduced himself as a certain U.S. Army Lt. Colonel, Retired. He went on to say, "I was in Libya, as an officer, when they kicked us out several years ago; and I was in Turkey when they kicked us out there. Our "brass" could not understand why these two countries, which had been befriended by the United States with substantial financial aid, could do this. Here the answer was in the word of God all the time."

3. Libya. The Hebrew is "Phut" (Genesis 10:6) or "Put" (1 Chronicles 1:8), and refers to the third son of Ham. Put migrated to the land west of Egypt and became the source of the North African Arab nations such as: Libya, Algeria, Tunisia, and Morocco. The Septuagint translates "Put" as Libya. In 1972, Libya kicked the U.S. Air Force out of her borders, to the astonishment of our military leaders. Libya embraces Russia and will be with her when Russia invades Israel.

4. Ethiopia. The Hebrew is "Cush" and is always Ethiopia. According to the Bible, Cush was born black and represents the black Africans, while Libya represents the African Arabs. A few years ago, when Haile Selassie (who professed to be a Christian) was the king of Ethiopia, they were a friend to Israel. Unfortunately, he was dethroned and died in exile. The country of Ethiopia then broke off the relationship with Israel. Today, Russia has equipped an army of thousands from among the Ethiopians and labels them as her "Army of Africa." Who is Ethiopia with today? Russia, just as God had said 2600 years ago.

5. Gomer. Going back to Genesis 10:2, we find Gomer was the firstborn of Japheth. He and his descendants settled in the area now known as Germany. Jews today call Germany by the Hebrew "Gomer." At the end of World War II, in 1945, Russia was in control of Germany. In 1949, Germany was divided and became East and West Germany. West Germany became a parliamentary democracy with strong ties to Western Europe, while the East became a communist dictatorship associated with

VIII. Prophecy

Soviet Russia.

In 1989, there was political unrest and reform movements that set in motion a chain of events that brought about the unification of East and West Germany. The Unification Treaty was signed October 3, 1990, and, in December, the first national elections were held. This was an important event, as God's word says Germany will be with Russia—not a divided Germany. At the moment, she is free from Russia; but, watch for Russia to "come in the back door" and befriend her with aid and supplies (military and otherwise) to win her confidence. God said in Ezekiel that Germany will be with Russia in the latter days. Keep watching your paper for the news, as you see this develop!

5. When Will Russia Attack Israel?

The Word of God in Ezekiel, Chapters 38,39, and Daniel, Chapter 9, lets us know *when* Russia will invade Israel. Ezekiel 38:8 reveals that Israel will be a nation in their land of Palestine and dwelling in safety. They were recognized by the United Nations May 14, 1948, as a sovereign nation. Since that time they have never dwelt in peace and safety. She fought wars in 1955 and 1956. In 1967, Israel had a tremendous victory in what was called the 6-Day War. 1973 was a different story! Israel lost as much as she had gained in the 1967 war. In the 1973 Yom Kippur War, during the first few hours, Israel lost about 5,000 men, over 600 tanks, and almost all of her air force was knocked out of the sky. Had it not been for the United States, Israel would have "gone down the drain" right then! We came to her aid in replenishing everything she had lost. The 1974, August issue, of Reader's Digest called it the greatest airlift in History when President Nixon and the United States backed Israel.

The heads of Israel, Egypt, Palestine, and Jordan will be meeting in the White House. However, Israel will not have any peace, no matter how many peace agreements are signed; until

VIII. Prophecy

she makes a covenant with the Antichrist, who promises her perpetual peace, according to Daniel 9:27a.

"And he shall confirm the covenant with many for one week: "

This will not take place until right after the Rapture. Israel will erect her Temple and offer the sacrifices under the old Levitical system. A school in Tel Aviv has been training hundreds of "cohen" (priests) for just such service. Of course, there will be no true peace for Israel until the Kingdom Reign of our Lord Jesus Christ

Ezekiel 38:8,11,14 shows us that Israel will not have an army, soldier or weapon to defend herself with; as her full confidence will be in her covenant with the Antichrist, whom she believes to be the long-promised Messiah. Israel will believe she is *"dwelling safely."* Ezekiel 38:15 tells us Russia will invade with an army on horseback, not with atomic or nuclear weapons. Why? That is all she will need as Israel will be defenseless.

6. Why Will Russia Attack Israel?

Ezekiel 38:13; 19:1,2; 1 Kings 11:42,43

Russia will not join forces with the Antichrist. She will want to rule the world under her own power and dictatorship with her five allies. To do this, Russia must have control of the money. Some have projected she will attack Israel for her oil; but, this is not true, as Russia has all the oil she needs from her allies, especially Libya and Iran. Russia, itself, has oil fields, plus potential recoverable reserves.

The reason is given in Ezekiel 38:13,

"Sheba and Dedan, and the merchants of Tarshish, with all the young lions thereof,...to carry away silver and gold..."

Whoever controls the money—controls the people! "Sheba and Dedan" is none other than present-day Saudi Arabia. The Bible Encyclopedia tells us that three-fourths of Saudi Arabia is

VIII. Prophecy

mountainous and known for its gold mines. In 1 Kings 10:2, the queen of Sheba brought "**VERY MUCH GOLD**" to Solomon.

The "young lions" are the princes (leaders) of Israel. (Ezekiel 19:1,2).

*"Moreover take thou up a lamentation for the princes of Israel,
(1) And say, What is thy mother? A lioness: she lay down among
lions, she nourished her whelps among young lions."*

Where will Israel get the gold that Russia will come after? She could rediscover her old mines or discover new ones. Perhaps she could unearth Solomon's tomb. We know from 1 Kings 11:42,43 that Solomon was buried in the City of David, which is Jerusalem. He was buried with billions of dollars worth of gold; part of which his father, David, had accumulated; and part which he, himself, had amassed during his 40-year reign as king.

Jerusalem is now a large city; but, in Solomon's time, it was only about 4 acres in area. The conflict between those excavating; and the opposition of the Orthodox Jews has continued to this day. Everything is "hush-hush" about Solomon's tomb. The Jews know it is in Jerusalem *somewhere*, if it has not already been secretly located.

Russia will invade Israel and Saudi Arabia right after the Rapture, with the intent to obtain the gold and rule the world.

7. How Will God Destroy the Armies of Russia & Her Allies?

Ezekiel 38:18,21,22; Ezekiel 39:2;

In Ezekiel, Chapters 38, 39, "Gog" is referring to the ruler of the country, and "Magog" is the nation of Russia. In Ezekiel 38:18 God says,

*"And it shall come to pass at the same time when Gog shall come
against the land of ISRAEL, saith the Lord God, that my fury
shall come up in my face."*

VIII. Prophecy

The total annihilation of Russia and her allies is given in Ezekiel 39:2,

"And I will turn thee back, and leave but the sixth part of thee, and will cause thee to come up from the north parts, and will bring thee upon the mountains of Israel."

Notice carefully the word "sixth." It is the Hebrew "shashah," but this is not the word that appears in the Hebrew text. The Hebrew word in the manuscript is the Hebrew "shawshaw" meaning "TOTAL ANNIHILATION." The two words are similar in spelling, pronounced the same; but have entirely different meanings! The literal reading should be, "I will turn thee back, and will leave nothing but *"total annihilation"* of thee."

In Ezekiel 38:22, God makes it perfectly clear that He will be the one to render the judgment and destruction of Russia and her armies, not the Anti-Christ. This verse describes how the judgment will fall.

"And I will plead against him with pestilence and with blood; and I will rain upon him (Russia), and upon his bands (i.e., her allies: Persia, Ethiopia, Libya, Germany and Turkey), and upon the many people that are with him, an overflowing rain, and great hailstones, fire, and brimstone."

1. "*Pestilence:*" The Hebrew is "deber" and means – some kind of physical plague or sickness. God has used physical diseases many times for those who rebel against Him. He warned Israel before they went into the Promised Land, that if they rebelled against Him, He would bring physical infirmities upon them which could not be healed. (Deuteronomy 28:35).

2. "*I will rain.:*" Hebrew is "matar," a general rain.

3. "*Overflowing rain.:*" The Hebrew for this "rain" is "geshem" from a root word meaning (to rain violently, gush down, wash away), and thus described as an overflowing rain.

4. "*Great hailstones:*" These hailstones are the size of a "talent" in the Greek, which is about 120 lbs. each. The Hebrew

VIII. Prophecy

for great hailstones is equivalent to those described in Revelation 16:21.

“And there fell upon men a great hail out of heaven, every stone about the weight of a talent: and men blasphemed God because of the plague of the hail; for the plague thereof was exceeding great.”

God has used hailstones in His wrath of judgment many times. For examples, see Joshua 10:11; Exodus 9:22-26.

5. “*Fire:*” Leviticus 10:1,2, destroyed Nadab and Abihu, sons of Aaron; Numbers 11:1, consumed complainers; Numbers 16:2,3,35, consumed 250 princes of Israel.

6. “*Fire and brimstone:*” Genesis 19:24,25 – Sodom and Gomorrah. Brimstone is the Hebrew “gophriyth” – describing it best as a resin, as from a cypress and sulphur, as equally flammable. This is the wrath of God and the means He uses to destroy Russia and her armies.

When this judgment is rendered of God, it ignites the men of these armies to actually kill each other. Notice Ezekiel 38:21.

“And I will call for a sword against him throughout all my mountains, saith the Lord GOD: every man's sword shall be against his brother.”

8. *When Will the Armies of Russia & Her Allies Be Destroyed?*

Ezekiel 39:10,12

After this destruction, it will take Israel seven years to burn all the weapons of these six great nations, led by Russia. “*And they shall burn them with fire seven years.*” (Ezekiel 38:9). This confirms that Russia and her allies begin the Battle of Gog and Magog, as it is prophetically called, soon after the Rapture. It will take Israel seven months to bury all the visible dead. (Ezekiel 39:12). After that, they will continue to search for charred and buried bodies beneath the rubble. Ezekiel 39:14c tells us that, “*After the end of seven months shall they search*

VIII. Prophecy

(i.e., for more corpses)." All of this was foretold 2600 years ago.

2 Peter 1:21 tells us,

"For the prophesy came not in old time by the will of man: but holy men of God spake as they were moved by the Holy Ghost."

2,000 years ago, Jesus Christ prophesied that,

"He that believeth on the Son hath everlasting life: and he that believeth not the Son shall not see life; but the wrath of God abideth on him." (John 3:36)

9. Will Children Go at the Rapture?

Question: When the Rapture comes, will all the children be taken also? Or will only the believer's children be taken? When Israel went into the Promised Land, the heathen's children were not spared.

Answer: First, it should be realized that children fall into two groups. Those who have not reached the age mentally to be accountable to God who, should they die, would go to Heaven. In Luke 18:15,16 we are told, *"They brought unto him also INFANTS..."*, and Christ said, *"...for OF SUCH is the kingdom of God."* The age of accountability of a child is known only to God, and varies with the child. Should a baby die now, it is part of the body of Christ, just as it is while living.

1 Corinthians 15:50,51, in speaking of the Rapture says,

"Now this I say, brethren, that flesh and blood cannot inherit the kingdom of God; neither doth corruption inherit incorruption.(50) Behold, I shew you a mystery; We shall not all sleep (die), but we shall ALL be changed."

The "all" would include even babies who are also part of the body of Christ. Those children, the second group, that are of the age of accountability will be left behind.

You mention the children of the heathen parents whom God had ordered the Israelites to kill. Those heathen children, under the age of accountability, upon death, would enter the kingdom

VIII. Prophecy

of God. Had God allowed them to continue, they would have been taught to worship other Gods as their heathen parents did. Thank God for His wisdom and grace. God allowed the children to die, so they could live with Him eternally in His kingdom; instead of allowing the parents to raise them as heathen, destined for an eternal Hell. We need to look at things through God's eyes, instead of our own.

10. Can I Be Saved After the Rapture?

Question: Hi! As a young person, I am concerned about the Rapture. I want to know if those who are left behind have a chance to get into Heaven after the Rapture?

Answer: When the Rapture occurs, all Christians are changed in a moment, in the twinkling of an eye (1 Corinthians 15:52), and caught up to be with the Lord in Heaven. (1 Thessalonians 4:17). At this point, the 7-Year Tribulation Period begins. At the end of the Tribulation, Christ returns to the earth and establishes His Kingdom which lasts for a 1,000 years. The last 3-1/2 years of the Tribulation Period is known as the Great Tribulation (Matthew 24:21). The reason: in the middle of the Tribulation, after 3-1/2 years, the Antichrist enthrones himself as being God and commands the whole world to worship him. (2 Thessalonians 2:4).

The Antichrist's worshippers will be required to take the mark of 666 on their foreheads; or on their right hand. (Revelation 13:16-18). Those Christians who refuse and are apprehended will be beheaded. (Revelation 20:4). They will be labeled as trouble-makers, anti-establishment, and anti-world government; therefore, they must be eliminated. The true Christians will be labeled as "antichrist"; while the real Antichrist, himself, will be worshipped as God.

With this in mind, let us go to 2 Thessalonians 2:10,12:

VIII. Prophecy

"And with all deceivableness of unrighteousness in them that perish; because they received not the love of the truth that they might be saved.

And for this cause God shall send them strong delusion, that they should believe a lie ("The Lie," the Antichrist, see v.4.)

That they all might be damned who believed not the truth, but had pleasure in unrighteousness."

The Antichrist does not present himself as God until 3-1/2 years after the Rapture. Those who were lost and left behind at the Rapture can still be saved the first 3-1/2 years into the Tribulation. Remember the Two Witnesses in Revelation 11, the 144,000 Jews in Revelation 7:4, along with many others were saved at this time. Revelation 7:14 lets us know that,

"...These are they which came out of great tribulation, and have washed their robes, and made them white in the blood of the Lamb."

The ecumenicalism of today is nothing more than "programming" the populous to accept all religions and worship together. Those who follow this philosophy are pre-programmed to accept the Antichrist as God, be a member of his world church, and support his one-world government. God's warning is,

"...Believe on the Lord Jesus Christ and thou shalt be saved..."
(Acts 16:31).

And,

"Come out of her my people(Christians)." (Revelation 18:4)

Or, don't suffer punishment with the unbelievers when the judgment falls on Babylon. It is such a severe punishment that it takes all of Revelation 18 to tell the story. This proves there are many people who trust Christ during the Tribulation.

Actually, the Tribulation Period will be a great time of soul winning and evangelism; but, it will come with a price.

"And I saw thrones, and they sat upon them, and judgment was given unto them: and I saw the souls of them that were beheaded for the witness of Jesus, and for the word of God, and which had

VIII. Prophecy

not worshipped the beast, neither his image, neither had received his mark upon their foreheads, or in their hands; and they lived and reigned with Christ a thousand years."

11. Will Backslidden Christians Go at the Rapture?

Question: If I am backslidden and not serving the Lord when the Rapture takes place, will I be left behind?

Answer: Several passages answer our question. Space prohibits giving them all; but, here are a few.

1. 1 Thessalonians 1:10.

"And to wait for his Son from heaven, whom he raised from the dead, even Jesus which delivered us from the wrath to come."

The original Greek for "delivered" is in the future tense, not the past tense. The "wrath to come" is the 7-Year Tribulation Period. (See Revelation 6:16,17). In other words, we are to wait for Christ to come (Rapture), who will deliver us (the Christian) from the "wrath" (i.e., Tribulation Period) which is coming. The Christian is not looking for Christ to come to deliver us from Hell, for we are already delivered from this. The Christian is looking for Christ to come to deliver us from God's wrath during the Tribulation Period.

2. 1 Corinthians 15:50-54 is speaking of the Rapture. The bodies of those Christians that have died ("this corruptible") will "put on incorruption" (i.e., bodies that will never decay). The "mortal" (those that are alive at the Rapture) will "put on immortality" (bodies that will never taste death again). Verse 51 says,

"Behold I shew you a mystery; we shall not all sleep (die), but we shall ALL be changed."

"ALL" means every Christian; those not serving the Lord as well as those who are.

3. 1 Thessalonians 5:1-11 is also speaking of the Rapture; and this lets us know that the Christian who is "sleeping on the

VIII. Prophecy

job of his, or her, responsibilities," and the Christian who is "watching and serving the Lord" will leave together. Notice Verses 9,10.

"For God hath not appointed us to wrath (the Tribulation, Revelation 6:16,17), but to obtain salvation ("deliverance") by our Lord Jesus Christ." (9)

"Deliverance" and "salvation" are from the same Greek word.

"...Who died for us (the Christians), that, whether we wake (same word as "watch" in Verse 6, i.e., serving the Lord) or sleep (the Greek is NOT "death"; but "backslidden", or "sleeping on the job"), we should live together (Gr. is "hama" or "together at the same time") with him." (10)

In other words, this Scripture is saying that all Christians are delivered from the Tribulation at the same time, regardless of their spiritual condition.

Titus 2:13 tells us that we are,

"Looking for that blessed hope, and the glorious appearing of the great God and our Savior Jesus Christ."

We are NOT looking for the "glorious appearing of the Tribulation, " the day of wrath upon the earth; but, will be delivered from that!

12. When Will All Of Israel Be Saved?

Romans 11:26

Question: Why do I hear so much preaching about how ALL OF ISRAEL will be saved? I would love to see the people of Israel accept CHRIST as LORD AND SAVIOR; but the way it is being taught sounds to me like ethnic salvation, because they are born Jewish. And the Bible clearly says that all who say they are Israel are not Israel. Israel is the church, is it not?

Answer: No! Israel is not the Church. Much confusion has been caused by this "teaching." Through Abraham, Isaac, and

VIII. Prophecy

Jacob, God was forming a nation to ultimately produce the Messiah (Jesus Christ); and show Himself to the surrounding pagan nations. (Acts 13:47) This was during the dispensation of Promise, beginning with the call of Abraham (Genesis 12:1-3) and ending with the Exodus (Exodus 12:40), and also during the dispensation of Law, from the Exodus to the Cross.

God wanted the Jews to reach out and bring other nationalities to Him. They could become Jewish proselytes and keep the rituals and sacrifices. These sacrifices only covered sin; and the shedding of innocent blood showed what the Messiah would do when He went to the Cross. They believed and were saved, looking forward. We look back, and believe and are saved. When Christ came,

"He came unto His own, and His own received Him not." (John 1:11).

After the cross, we enter a new dispensation; the Church Age, or Age of Grace. Under Promise and the Law, God dealt through one nation, Israel. Under Grace, He deals with the world, all nationalities.

"Is he the God of the Jews only? Is he not also of the Gentiles? Yes, of the Gentiles also:" (Romans 3:29)

"There is neither Jew nor Greek, there is neither bond nor free, there is neither male nor female: ye are all one in Christ Jesus." (Galatians 3:28)

There is one kind of salvation for all.

"For God so loved the WORLD, that he gave his only begotten Son, that whosoever believeth in him should not perish, but have eternal life." (John 3:16)

It is not ethnic salvation. Everyone is saved the same way, by believing that Jesus Christ died to pay for our sins.

After the Rapture, we have the 7-Year Tribulation Period. God again deals with the Jews as a NATION for their rejection of Christ, and with the world as a whole for its ungodliness. It is

VIII. Prophecy

called "Jacob's Trouble." (Jeremiah 30:7; Daniel 12:1; Revelation 6-19).

The total quote from Romans 11:26 is

"And so all Israel shall be saved: as it is written, There shall come out of Sion the Deliverer (Christ), and shall turn away ungodliness from Jacob (the Nation of Israel):"

This occurs at the end of the Tribulation Period. THEN, the Jews will know the Antichrist is not the Messiah; and the Real One, King Jesus, has come on the scene! Individual Jews surviving at the end of the Tribulation Period will either believe in Christ as Messiah; or, if they have taken the Mark of the Beast, 666, by trusting the Antichrist (Revelation 13:16-18), will hear the devastating words...

"Depart from me, ye cursed, into everlasting fire."

It will be the same with surviving Gentiles. This occurs at the Judgment of the Nations (or "judgment of the survivors") at the end of the Tribulation and beginning of the Kingdom. (Matthew 25:31-46). The only surviving Jews entering the Kingdom will be believing Jews.

"...So all Israel shall be saved."

It is the same for the Gentiles.

Then begins the 1,000 year Kingdom when Christ reigns from Jerusalem. (Revelation 19, 20:4-6).

You have got to make the determination according to the context of the Scripture; as to whether a passage is speaking of individual salvation, or the nation as a whole.

13. Is This Present Earth Going to Be Renovated, or Annihilated?

Revelation 21:1

Question: I have a question about Revelation 21:1,

VIII. Prophecy

“And I saw a new heaven and a new earth: for the first heaven and the first earth were passed away; and there was no more sea.”

Is this present earth going to be renovated or annihilated?

Answer: Notice in Matthew 28:20, the last part of the verse,

“...and, lo, I am with you always, even unto the END OF THE WORLD. Amen.”

It is important to acknowledge the three Greek words translated “world” in our English language and their meanings.

1. “KOSMOS.” The primary meaning is, “adornment, embellishment, etc., and refers to God’s beautiful creation. We get our English word, cosmetics, from this Greek word. In 1 Peter 3:3 concerning women, the Greek “KOSMOS” is appropriately translated “adorning.”

“Whose adorning (kosmos) let it not be that outward adorning of the plaiting of hair, and of wearing of gold, or of putting on of apparel.”

Notice 2 Peter 3:6 reference the Flood.

“Whereby the world (Gr. kosmos) that then was, being overflowed with water, perished.”

The word “perish” in this verse is also translated “destroy” in other places. The Greek word is “apollumi”, and is not referring to extinction; BUT, rather, ruin, loss—not of being, but of well-being—whether applying to planet earth or human beings. In other words, just as “kosmos” is in reference to the beautification of God’s earth; or the adornment (Gr. “kosmos”) of a woman with cosmetics, it is in reference to the exterior, not the whole of the earth itself. This is also in perfect accordance with the word “perished” in 2 Peter 3:6. Therefore, the beautiful exterior, along with mankind, was destroyed, or perished, by the Flood; BUT, not the earth, itself.

2. “AION.” This Greek word is our English word “AEON,” or spelled as “EON.” This is a transliteration from the Greek to our English. It is used as “an end of an era, or age, or dispen-

VIII. Prophecy

sation of time; or as an order of things.” “Aion” is translated as “world” in Matthew 28:20, but should be translated “AGE.” In other words, the last half of the verse would properly read,

“...I am with you alway, even unto the end (consummation) of the World (i.e. age).”

3. “GE”. This Greek word is used in reference to the earth, or ground, “the terrestrial globe.” It is translated as “earth” in Matthew 13:5 and “ground” in Verses 8, 23. Notice the Greek “ge” is brought into our English, being the first syllable of our English words: Geography, Geophysics, Geometry, etc.

Now, referring back to Revelation 21:1 in reference to the words, “passed away” concerning the first heaven and first earth. “Passed away” is translated as such from the Greek word, “PARERCHOMAI.” “PARA” means “from” and “ERCHOMAI” means “by.” Literally, the Greek word means, “to pass by or pass away.” Notice in Mark 13:31,

“Heaven and earth shall pass away...”

The Greek word here is "PARERCHOMAI." This primary meaning is not “annihilation or extinction;” BUT, rather, “a change from one place, or kind, or situation to another.” In other words, this earth is going to pass from its present condition, undergoing a vast change and a tremendous remodeling or renovation.

At the end of the Millennial Reign of Christ on this earth, the Great White Throne Judgment for the lost will occur. All the lost are cast into the Lake of Fire (Revelation 20:14,15), along with Satan (Revelation 20:10), for all time and eternity. Then, God will remodel this old earth into a new earth to be inhabited by only the saved in their resurrected bodies. It will, therefore, be completely free from sin, sorrow, and death (Revelation 21:4).

While we are on this subject, may I briefly point out that there is another “regeneration” or “rebirth” concerning this old

VIII. Prophecy

world. This will be in effect all during the Thousand-Year Reign of Christ in His Kingdom here on earth, PRIOR to the new heavens and new earth.

Notice in Matthew 19:28,

“...Verily I say unto you, That ye which hath followed me, (Christ) in the REGENERATION (i.e., in Christ’s reign on earth for a thousand years) when the Son of Man shall sit in the throne of his glory,...”

The Greek word for “regeneration” is “PALINGENESIA.” “Palin” means “again” and “genesis” means “birth. Spiritually applied, it is a new birth in Jesus Christ, when one accepts Him as their personal Savior. As applied to the Kingdom in Matthew 19:28, the Kingdom will be a *new birth* from what it was. In other words, “regeneration” will literally mean that the earth will run under the absolute authority of Jesus Christ for a thousand years. This is in contrast to the way unregenerate man has ruined it by orchestrating his philosophy, instead of God’s principles, for the last 6,000 years.

Notice in Acts 3:19-21,

“Repent (Greek, “change your mind”) ye therefore and be converted, that your sins may be blotted out, when the times of refreshing shall come from the presence of the Lord; (19) And he shall send Jesus Christ, which before was preached unto you: (20) Whom the heaven must receive unto the times of restitution of all things, which God hath spoken by the mouth of all his holy prophets since the world began.” (21)

The word “RESTITUTION” is the Greek “apokatastasis.” (From “apo” meaning “back again” and “kathistemi,” meaning, “to set in order.”) In other words, the Kingdom will be set in order according to God’s word as spoken by the prophets, some of which include the following:

1. Peace in the animal kingdom. (Romans 8:19-22; Isaiah 11:6-8).
2. Earth full of the knowledge of the Lord. (Isaiah 11:9).

VIII. Prophecy

3. Desert shall produce. (Isaiah 35:1).
4. Three nations—Egypt, Assyria, and Israel—, born in a day, all will serve the Lord (Isaiah 19:23-25).
5. Dead Sea will be healed. (Ezekiel 47:1-12, note: the “sea” in v.8 is the Dead Sea.).
6. Temple in Jerusalem will be rebuilt. (Ezekiel 41; Zechariah 6:12,13).
7. City of Jerusalem rebuilt. (Jeremiah 31:38 and 30:18).
8. Christ will sit in the Holy of Holies. (Zechariah 6:12,13).

These are just a handful of the myriads of prophecies that will be in fulfillment, and fully justify the words “regeneration” and “restitution of all things.”

The main difference between the Millennium and the “new earth” is:

1. In the Millennium there will be sin present in unbelievers. Sin will not be allowed to display itself; such as murder, theft, adultery, rape, kidnapping, molestation, etc.
2. In the new heavens and earth there will be no sin; since all Christians will be void of the old sin nature which was done away with when they received their new, glorified bodies. (Philippians 3:20,21).

All of these wonderful things— the new heavens and new earth, the New Jerusalem— will be enjoyed by those who have accepted the Lord Jesus Christ as their personal Savior. Not so with the lost. They will be cast into the Lake of Fire for all eternity.

“...Believe on the Lord Jesus Christ, and thou shalt be saved...”
(Acts 16:31),

VIII. Prophecy

...saved from eternal damnation (John 5:24).

14. Is The Rapture Before, During; Or, After the Tribulation Period?

Question: Will the Church, or as some call it, the Body of Christ, be raptured before, during, or after the 7-year Tribulation of God's Judgment? I have heard so many views on this.

Answer: The Church Age began on the Day of Pentecost, over 2,000 years ago, and will end with the Rapture. The Rapture will begin the 7 years of tribulation, which will end with Christ coming to the earth and establishing His Kingdom for a 1,000 years. We will confine ourselves strictly to the question you have asked. I will list some of the false claims and show from Scripture why they are not true.

1. The Post-Tribulation Rapture.

One false claim is that the Rapture is the same event as the coming of Christ at the end of the Tribulation. This has confused many, leading them to believe in what is called the "Post-Tribulation Rapture."

Refutation: First of all, at the Rapture, the saved are "caught up" or taken to be with Christ in the air. (1 Thessalonians 4:16,17). In Matthew, Chapters 24,25, we have Christ coming to the earth and judging the nations.

Matthew 24:40 is used by some, saying it is the Rapture.

"Then shall two be in the field; the one shall be taken, and the other left."

Notice, as we quote Matthew 25:31-34, which makes it perfectly clear that this judgment involves 3 things: (1). Christ comes to the earth, (2). He will sit on His throne, (3). He will separate the saved from the lost.

"When the Son of man shall come in his glory, and all the holy angels with him, then shall he sit upon the throne of his glory: (31) And before him shall be gathered all nations: and he shall separate them one from another, as a shepherd divideth his sheep

VIII. Prophecy

(saved) from the goats (lost): (32) And he shall set the sheep on his right hand, but the goats on the left. (33) Then shall the King say unto them on his right hand, Come, ye blessed of my Father, inherit the kingdom prepared for you from the foundation of the world.” (34)

Matthew 25:41 tells us what happens to the lost.

“Then shall he say also unto them on the left hand, Depart from me, ye cursed, into everlasting fire, prepared for the devil and his angels:”

Notice carefully, the difference between the Rapture spoken of in 1 Thessalonians 4:16,17 and Christ’s Coming, spoken of in Mathew, Chapters 24,25.

a. At the Rapture, Christ does not come to the earth, as we are caught up to meet Him in the clouds. Whereas, in Matthew, Christ comes to the earth to establish His Kingdom.

b. Notice carefully, at the Rapture in 1 Thessalonians, the saved are the ones taken while the ones left are the lost. Just the opposite takes place in Matthew. Those that are taken are the lost; while those that are left are the saved who enter into the Kingdom in their earthly bodies. Therefore, it is imperative for the Bible student to understand that these two events are entirely different, being separated by the Seventieth Week of Daniel, known as the 7-Year Tribulation Period. Without acknowledging the difference between Christ’s coming for his Church and His coming to establish the Kingdom; one will only be led into more error concerning Bible prophecy.

Note: A good principle to remember is, whenever Christ’s return is spoken of in Matthew, Mark, Luke, or John, it is never the Rapture; but, rather, the return of Christ at the conclusion of the Tribulation. The Rapture was a mystery, revealed unto the Apostle Paul after the Church Age had begun. (Ephesians 3:1-10).

2. A Pre-Tribulation Rapture Is What The Bible Teaches.

Now let us examine the proof:

VIII. Prophecy

1 Thessalonians 1:10:

“And to wait for his Son from heaven, whom he raised from the dead, even Jesus, which delivered us from the wrath to come.”

In examining this verse there are three things we need to recognize:

a. Paul was writing to Christians (1:1 and 5:25). They were already delivered from the wrath of Hell. (John 3:36).

b. Notice *“which delivered us”* is translated in the past tense. This is incorrect, as the Greek has it in the future tense. It should read as *“who delivers us,”* or, *“which will deliver us.”*

c. The *“wrath to come”* is not in reference to Hell; but, rather, to the Tribulation Period. Revelation 6:17,

“For the great day of his wrath is come; and who shall be able to stand?”

Therefore, the Christians that are alive at the Rapture will not go into the Tribulation, known as the *“day of his wrath.”* Notice the word *“us,”* which includes all Christians, the spiritual and the backslider. As many say, *“The Church is not ruptured; but, raptured!”*

1 Thessalonians 5:9:

“For God hath not appointed us to wrath (Tribulation wrath, same as 1:10); but to obtain salvation (i.e., “deliverance”) by our Lord Jesus Christ.”

The Greek word for *“salvation”* is *“SOTERIA”* and denotes *“deliverance, preservation, salvation.”* For example: In Acts 27:34, the word *“health”* is from the Greek *“soteria.”* In other words, in Verse 33 we find the sailors had gone 14 days without eating. In Verse 34 Paul said, *“...take (or eat) some meat: for this is for your health,”* (i.e. "your deliverance") from getting sick or dying.

Also, in Philippians 1:19, *“salvation”* should have been translated *“deliverance,”* since he was speaking about his

VIII. Prophecy

deliverance from the prison from which he had written to the Philippians. A literal translation of Verse 9 would read,

“For God hath not appointed us (Christians) to the wrath of the tribulation, but to obtain deliverance from it, when the Lord Jesus Christ comes for His Church.”

In Chapter 4, verses 13-18, we have the Rapture. Chapter 5 continues with Christ’s return at the Rapture, assuring all Christians that they will be delivered from the Tribulation Period.

3. Spiritual & Carnal all Raptured At the Same Time.

The following Scriptures refute the erroneous and false teaching that only the spiritual Christians will be raptured; while the carnal Christians will have to go through the Tribulation. We will continue; as we examine and analyze the next verse, 1 Thessalonians 5:10. *“Who died for us, that, whether we wake or sleep; we should live together with him (Christ).”* We will look at 3 important words in this verse.

a. *“Wake.”* It is the same Greek word “gregoreo” as translated “watch” in Verse 6. *“Therefore let us not sleep, as do others; but let us WATCH and be sober.”*

b. *“Sleep.”* The Greek word for “sleep” in Verse 10 is the same as that for “sleep” in Verse 6. *“Therefore let us not sleep, as do others; but let us watch and be sober.”* Therefore, sleep is in reference to those Christians who are “lying down on the job” and not serving the Lord. Some perverted minds try to proclaim that “sleep” here is referring to “death.” If that were true—how would you “watch and be sober” if you were dead? Preposterous!

c. *“Together.”* The Greek word is “hama” and means “together at the same time.” (*Vine’s Dictionary of New Testament Words*).

Now, let us put Verse 10 together and write it out, including the meaning of each of the 3 words we have examined.

VIII. Prophecy

“Who died for us, that, whether we wake (watching and serving the Lord) or sleep, we should live together (at the same time) with him (Christ).”

These Scriptures clearly set forth the truth that ALL Christians, those serving the Lord and those who are not, will be raptured together at the same time.

4. The Rapture Is The Redemption of Our Body.

A partial Rapture is Satan’s trickery to lead one to believe that you must suffer and/or have good works to complete God’s salvation. One must remember that the completion of our salvation is the redemption of our bodies! Notice Romans 8:23,

“...even we ourselves groan within ourselves, waiting for the adoption, to wit, THE REDEMPTION OF OUR BODY.”

At the Rapture our salvation is completed. Those who have died, receive their resurrected bodies from the grave; while those that are alive have their bodies transformed as they go up to be with the Lord. (Philippians 3:20,21).

Those who propagate a partial Rapture have succumbed to Satan’s subtlety. (Genesis 3:1 and 2 Corinthians 11:3,13-15). If Satan cannot convince you that good works are necessary for salvation; then, he will attempt, through his ministers, to convince you that those that are backslidden must go into the Tribulation. Some that hold this view have told me that, this is to have them suffer for their disobedience and give them a chance to redeem themselves. This, supposedly, shows God they are really Christians by now being faithful while being persecuted. Sounds good—except it contradicts God’s Word!

This damnable philosophy denies the Judgment Seat of Christ for all Christians, as well as Christ’s completing our salvation by His death and Resurrection. Therefore, they do not believe one is saved eternally; but, rather, must have good works in order to maintain their salvation. Very subtly, they accuse God of being a liar and unfaithful to His Word when He promised all

VIII. Prophecy

believers they would “*never perish, but have everlasting life.*” (John 3:16).

5. Both Spiritual and Carnal Christians Go At The Rapture.

“Beloved, now are we the sons of God, and it doth not yet appear what we shall be: but we know that, when he shall appear, WE shall be like him; for WE shall see him as he is.” (1 John 3:2)

The “we” is all-inclusive of the spiritual and the carnal Christian. No distinction between the two is made here.

“Behold, I shew you a mystery; We shall not all sleep, but WE shall ALL be changed.” (1 Corinthians 15:51)

At the Rapture, ALL or every Christian, whether spiritual or not, will be changed, i.e., receive their glorified bodies. Notice the last 4 words in Verse 52,

“...and WE shall be changed.”

The “WE” is all-inclusive of every Christian. Again, a partial Rapture philosophy disintegrates in the light of God’s Word. In 1 Thessalonians 4:17, notice the “WE.”

“Then WE which are alive and remain shall be caught up together with them in the clouds, to meet the Lord in the air: and so shall we ever be with the Lord.” (1 Thessalonians 4:17)

Again, the Holy Spirit uses the word “WE,” eliminating any distinction between the spiritual and carnal Christian; thus, illuminating the false teaching of a partial Rapture.

6. No Such Thing As A Post-Tribulation Rapture

Some final thoughts sealing the fate of the philosophy of a post-Tribulation Rapture. Follow with me as we look at some basic facts:

- a. All raptured Christians receive their glorified bodies. (Romans 8:22,23; 1 Corinthians 15:50-54).
- b. There are no children born to glorified bodies. (Matthew 22:23-30).
- c. All unsaved are cast into Hell before the 1,000 Year

VIII. Prophecy

Kingdom Reign of Christ. (Revelation 19:11-21 and Matthew 25:41).

d. If the Rapture is post-Tribulation, several problems arise with impossible solutions.

- (1). Where do the mortal bodies come from of those that are born during the Millennium and rebel at the conclusion of the Millennium? (Revelation 20:7-10).
- (2). There would be no lost people alive to have children, so they cannot come from them.
- (3). All of the saved have their glorified bodies. No children can be born to them as a result of a post-Tribulation Rapture.
- (4). Remember, at the end of Christ's 1,000 Year Reign there are unbelievers who will give their allegiance to Satan in an attempt to defeat Christ. (Revelation 20:7-10). How did they get their human bodies? Placing the Rapture at the end of the Tribulation and the start of the Millennium makes an impossible situation.

At the Rapture all Christians have their glorified bodies, which do not produce human beings. All the lost are cast into Hell; therefore, the philosophy of a post-Tribulation Rapture is impossible. The Post-Tribulation Rapture philosophy also leads to other false doctrines. Colossians 2:8 is God's warning concerning false teachers,

“Beware lest any man spoil you through PHILOSOPHY and vain deceit, after the tradition of men, after the rudiments of the world, and not after Christ.”

If a Post-Tribulation Rapture were true; then, the last generation alive would be the only generation in over 2,000 years since the Church Age began, to have to go through the Tribulation. Then, we would have to conclude that God is not a just God.

VIII. Prophecy

If the Rapture is at the conclusion of the Tribulation; then, why are we not told to be praying for “that blessed hope and glorious appearing of that blessed tribulation!” Yet, the Word of God tells us, in Titus 2:13, that the Christian is to be,

“Looking for that blessed hope, and the glorious appearing of the great God and our Saviour Jesus Christ.”

7. Conclusion.

In conclusion, we shall examine one more proof of a Pre-Tribulation Rapture as opposed to a Post-Tribulation Rapture. Our text is recorded in 2 Thessalonians 2:1-9.

a. Investigating our Text. In Paul’s first epistle to the Thessalonians, he mentions Christ’s return at the end of each of the five chapters. In Chapter 4:13-18, he goes into great detail in describing what occurs at the Rapture. This was a great comfort to these Christians, as he advises them in Verse 18,

“Wherefore COMFORT one another with these words.”

Sometime later, someone had sent a letter, evidently ascribing Paul’s name, and indicated that the Rapture had already taken place; whereas, they were left behind. Paul had gotten word of this and addressed the issue in his second epistle to the Thessalonians, beginning at 2 Thessalonians 2:2.

“That ye be not soon shaken in mind, or be troubled, neither by (a) spirit, nor by (a) word, nor by (a) letter as from us; as that the day of Christ (i.e., LORD) is at hand.”

The “*day of Christ*” should be translated “the day of the LORD,” which is the correct translation. Distinguishing between,

- The Day of Man (the Church Age),
- The Day of Christ (the Tribulation of 7 years from the Rapture to the Revelation of Christ),
- The Day of the LORD (Jehovah) (from the middle of the Tribulation to the end of the Millennium),

...is imperative to understanding Verse 2.

VIII. Prophecy

Therefore, if the Day of Jehovah was at hand, then the Rapture would have already taken place. No wonder they were troubled and worried! Paul, in Verse 3, sets the doctrine straight. The Day of the LORD was not at hand, as the Rapture and the enthronement of the Antichrist as God must take place first. In other words, “The letter you received was a forgery and you have not missed the Rapture!”

Then, in 2 Thessalonians 2:5, Paul reminds then,

“Remember ye not, that, when I was yet with you; I told you of these things?”

We now examine 2 Thessalonians 2:3,

“Let no man deceive you by any means: for that day (day of LORD) shall not come, except there come a falling away (departure) first, and that man of sin be revealed, the son of perdition.”

We are now introduced to the Greek word “apostasia” which is translated as “falling away” in the King James Translation. The basic meaning of the word is “departure.” One cannot tell from the meaning of the word, itself, whether it is in reference to the departure, i.e., the Rapture of the Church; or, a “departure from the truth,” known as apostasy. “Apostasia” translated as “falling away” is quite misleading; as it does not incorporate the meaning “to fall” or “fell.” For example, check Matthew 10:29 (“fall”); Matthew 17:6 (“fell”); John 18:6 (“fell”), etc. These are translated from the Greek word “pipto,” not “apostasia.” Therefore, only by the context in which “apostasia” occurs can it be determined if it is in reference to a departure from the faith; or the departure of the Church from the world.

It should be noted, that to the best of my knowledge, all English translations prior to the King James Translation translated “apostasia” either as “departing” or “departure.” Also, the Bible known as the Vulgate, about 400 A.D., was Jerome’s Latin translation. Here Jerome uses the Latin word “discessio”, meaning “departure” for “apostasia.”

VIII. Prophecy

With this in mind, one can see that this is in perfect harmony with Verse 1, which speaks of the Rapture.

“Now we beseech you, brethren, by the coming of our Lord Jesus Christ, and by our gathering together unto him.” (The Rapture).

This is the same as Paul had previously spoken about in 1 Thessalonians 4:17 concerning the Rapture.

“Then we which are alive and remain shall be caught up together with them in the clouds, to meet the Lord in the air: and so shall we ever be with the Lord.”

In 1 Thessalonians 4:13-17, Paul gives the principles of the Rapture; whereas, in 2 Thessalonians 2, he gives the procedure concerning the Rapture, which is Pre-Tribulation.

May we make a few more observations which lead us to conclude that “apostasia” in 2 Thessalonians 2:3 is speaking of the Church departing from the earth, raptured to meet her Savior in the clouds; and not a departure from the faith.

(1). Notice in Verse 7, *“For the mystery of iniquity doth already work.”* Paul states that apostasy from the faith was already present. Hymenaeus and Alexander were two of them. (1 Timothy 1:19,20). There were false teachers of the law. (1 Timothy 1:4-7). False teachings concerning the Resurrection. (2 Timothy 2:16-18). Read Jude; 1 John 2:18; 2 Peter 2:1-3; 1 John 4:1-3, and we could go on and on.

In other words, since the offspring of Adam and Eve, there has always been apostasy from the faith. What do we attribute the Flood to? In Israel there were the false prophets and priests. It was the same at the time of Christ; and ever since, to the present. Therefore, it would be ludicrous to think that “apostasia” in 2 Thessalonians 2:3 was in reference to “apostasy from the faith,” when there has never been a time when apostasy has not been with us.

Therefore, how would the Thessalonians recognize any apostasy different from the apostasy that already existed, and that

VIII. Prophecy

has always existed in one way or another. From the context, itself, we know the “apostasia” in Verse 3 is not in reference to departure from the faith, already existent; but, rather, a departure of the Church from the world, or the Rapture. Apostasy already existed as stated in Verse 7,

“For the mystery of iniquity doth already work...”

We have the same false teachers today, advocating a Partial or a Post-Tribulation Rapture, as those believers in Thessalonica encountered over 1900 years ago. As we have stated previously, the Christian is admonished to be *“Looking for that blessed hope, and the glorious appearing of the great God and our Savior Jesus Christ,”* NOT, “the blessed hope and glorious appearing of the Tribulation Period! (The Day of God’s Wrath.).

A final note. Many are not aware that the Roman Catholic Church does not believe in the Rapture. Also, the Evangelistic Lutheran Churches of America (ELCA); the Missouri Synod Lutherans, and the Wisconsin Lutheran Synod deny three basic prophetic doctrines: (1). They deny the Rapture, (2). They do not believe in the Restoration of the Nation of Israel, (3). They deny the literal reign of Christ in his earthly Kingdom on earth for 1,000 years. How did they come to these conclusions, denying major portions of the Word of God? Very simple. Their teachings were founded by a man named Martin Luther, who has been dead over 460 years! (Luther, 1483-1546). Maybe they are not familiar with the middle verse of the Bible, Psalm 118:8,

“It is better to trust in the LORD than to put confidence in man.”

15. Please Give An Explanation of Daniel 9:24-27.

Question: Please give an explanation of Daniel 9:24-27. I am totally confused by all the different interpretations of this passage!

Answer: I would say that you have a lot of company! I will

VIII. Prophecy

do my best to clear this up for you.

1. Daniel 9:24. (70 x 7 = 490 years). The Hebrew for “week” is “seven,” not days; but, rather years. Weeks ref. Genesis 29:18-27.

“Seventy weeks are determined upon thy people and upon thy holy city, to finish the transgression, and to make an end of sins, and to make reconciliation for iniquity, and to bring in everlasting righteousness, and to seal up the vision and prophecy, and to anoint the most Holy. (24)

Know therefore and understand, that from the going forth of the commandment to restore and to build Jerusalem unto the Messiah the Prince shall be seven weeks, and threescore and two weeks: the street shall be built again, and the wall, even in troublous times. (25)

And after threescore and two weeks shall Messiah be cut off, but not for himself: and the people of the prince that shall come shall destroy the city and the sanctuary; and the end thereof shall be with a flood, and unto the end of the war desolations are determined. (26)

And he shall confirm the covenant with many for one week: and in the midst of the week he shall cause the sacrifice and the oblation to cease, and for the overspreading of abominations he shall make it desolate, even until the consummation, and that determined shall be poured upon the desolate. - Daniel 9:24-27

- (a). “Thy people.” (Israel) (9:24a)
- (b). “Thy Holy City” (Jerusalem) (9:24b)
- (c). “To finish the transgression.” (9:24c)

“To finish the transgression” takes place within the 490 prophetic years. After the 70 Year Captivity, only about 50,000

VIII. Prophecy

Jews returned to Jerusalem to assist with the building of the Temple, as described in Ezra; and, rebuilding the walls, streets, and etc. of the city of Jerusalem under Nehemiah. Israel's many transgressions had brought about the 70 years captivity, as foretold in Jeremiah 25:11 and 29:10.

"To finish the transgressions" (9:24c) reveals to us that there are more transgressions to be made by Israel. Less than 500 years later, Israel had turned the Temple worship of Jehovah into a secular den of thieves, by the hypocritical scribes, Pharisees, and priests. (Matthew 21:12,13). In John 1:11,

"He (Christ) came unto his own, and his own received him not."

This transgression brought about God's judgment in 70 AD when Titus destroyed Jerusalem, slaughtered some 600,000 Jews, and carried thousands captive into Egypt. The rest that escaped fled for their lives, finding refuge wherever they could throughout the world.

Germany executed some 6,000,000. They began to trickle back in 1917 via the Balfour Declaration, until they were recognized as a sovereign state by the United Nations in May of 1948. They are there in unbelief as they still refuse to accept Jesus Christ as their Messiah. Their rebellion and transgression continues.

(d). *"And to make an end of sins, and to make reconciliation for iniquity."* (9:24d)

This takes place when Christ returns at the end of the Tribulation, when *"all Israel shall be saved."*

"And so all Israel shall be saved: as it is written, There shall come out of Sion the Deliverer, and shall turn away ungodliness from Jacob:" (i.e., Israel – Genesis 32:28).

VIII. Prophecy

“For this is my covenant unto them, when I shall take away their sins.” (v. 27). (Romans 11:26, 27).

(e). *“And to bring in everlasting righteousness.” (9:24e)*

This takes place when Christ returns to establish His Kingdom at the end of the Tribulation. Notice Jeremiah 3:17,18.

“At that time they (Israel) shall call Jerusalem the throne of the LORD; and all the nations shall be gathered unto it, to the name of the LORD, to Jerusalem: neither shall they walk any more after the imagination of their evil heart.” (v.17).

“In those days the house of Judah shall walk with the house of Israel, and they shall come together out of the land of the north to the land that I have given for an inheritance unto your fathers.” (v.18).

(f). *“And to seal up the vision and prophecy.” (9:24f)*

The prophecy in Daniel 9:24-27, which is the 490 years, is fulfilled when Christ returns at the end of the last 7 years of the Tribulation. He, then, establishes His Kingdom on earth. Therefore, this prophecy is at that time concluded. In other words, “Seal it up, as it is no longer of use, since time has swallowed it up in fulfilling its predictions.”

(g). *“And to anoint the most Holy.” (9:24g)*

Revelation 19 describes Christ’s return to earth and His defeating the Anti-Christ’s armies. He throws the Political Beast and the False Prophet into the Lake of Fire burning with brimstone. (v.20).

Israel’s Messiah, the Lord Jesus Christ, has come in victory and will establish His Kingdom!

“And he (Christ) hath on his vesture and on his thigh a name written, KING OF KINGS, AND LORD OF LORDS.” (v.16).

VIII. Prophecy

2. Daniel 9:25.

(a). The Commandment of Artaxerxes.

“Know therefore and understand, that from the going forth of the commandment to restore and to build Jerusalem unto the Messiah the Prince shall be seven weeks, and threescore and two weeks:...” (Daniel 9:25)

This commandment was given by Artaxerxes, the King of Persia to Nehemiah for the rebuilding of Jerusalem in, or about, 445 B.C. (Nehemiah 2:1-8). In other words, from Nehemiah to the Messiah would be 7 weeks (i.e. years) and threescore (a score is 20, or $20 \times 3 = 60$ years) and two weeks (years) which equals 69×7 ; or, literally, 483 years.

The Hebrew word translated “week” means “seven.” It is the same meaning as in Genesis 29:18 when Jacob said...

“...I will serve thee (Laban) seven years for Rachel thy younger daughter.”

Now notice in Verse 28...

“And Jacob did so, and fulfilled her week: and he (Laban) gave him (Jacob) Rachel his daughter to wife...”

The word “seven” in Verse 18, and the word “week” in Verse 28, are both from the same Hebrew root word meaning “seven.” The Hebrew ‘SHBUAH’ is the same word for “weeks” in Daniel 9:25, as it is for “weeks” in Genesis 29:28, meaning “seven.”

(b). We are also told in Verse 25 that the rebuilding of

VIII. Prophecy

Jerusalem would be done in troubled times of opposition.

“...the street shall be built again, and the wall, even in troublous times.” (9:25c)

Read Nehemiah through, and see Satan’s attacks upon those rebuilding the city, in fulfilling Daniel’s prophecy.

Satan’s missionaries today (atheists, agnostics, and false preachers) attack God’s Word, saying Daniel is just recorded History. How ignorant these men are, as the commandment was not given in Nehemiah, Chapter 2, to rebuild Jerusalem until about 95 years AFTER Daniel’s death. This was prophetic, as History would only fulfill what God had previously predicted.

Verse 25 lets us know that, from the edict given to rebuild Jerusalem and until the Messiah would be crucified, would cover a period of 483 years.

3. Daniel 9:26.

“...And after threescore and two weeks shall Messiah be cut off, ... (crucified).” (Daniel 9:26a)

In Verse 25 we have 483 years from the edict to rebuild Jerusalem to Christ being rejected and crucified. By subtracting 434 years from the 483 years, we know it took 49 years to rebuild the city of Jerusalem.

(a). *Messiah be cut off (crucified), but not for Himself.* Christ did not die for Himself, as he was the sinless Son of God.

“For he hath made him to be sin for us, who knew no sin; that we might be made the righteousness of God in him.” (2 Corinthians 5:21).

VIII. Prophecy

All humanity has sinned, and that sin was laid upon Christ on the cross, making our payment for us, as described in Isaiah 53:6.

“All we like sheep have gone astray; we have turned every one to his own way; and the LORD hath laid on him the iniquity of us all.”

(b.) *“And the people of the prince that shall come.”* (9:26b) (“The people” are the Romans). “Prince” is translated from “NAGID,” which in the Hebrew meaning is (a commander whether civil, religious, or military.) This would apply to Titus, the Roman general.

(c.) *“shall come shall destroy the city (Jerusalem) and the sanctuary.”* (9:26c)

This was accomplished by Titus in 70 A.D.

(d.) *“The end thereof shall be with a flood.”* (9:26c)

The destruction of the city and the Temple was concluded after a siege of 143 days, just shy of five months. The flood is in reference to the enormous amount of Jews that were slaughtered by the Roman Army. Flavius Josephus (37-100), the famous Jewish historian, says that there were over 1,000,000 Jews that died at the hands of Titus.

(e.) *“And unto the end of the war desolations are determined.”* (9:26e)

From the Diaspora (a scattering) in 70 A.D. of the Jews

VIII. Prophecy

throughout the world, “desolations are determined.” In other words, God has determined that there will be hatred (anti-Semitism), wars, and nations wanting them destroyed, and etc.

Note: Between Verses 26 and 27, the Rapture takes place. All Christians are gathered off of the earth and taken to Heaven.

We are going to stop here with the Rapture. Over 2,000 years ago, Israel made the biggest mistake in rejecting her Messiah, the Lord Jesus Christ. After the Rapture and examining Daniel 9:27, we shall see her second biggest mistake in accepting the Anti-Christ’s Covenant.

Note the following diagram, a timeline illustrating what God meant when he told Daniel, *“Seventy weeks (of years) are determined upon thy people (Israel)...”*

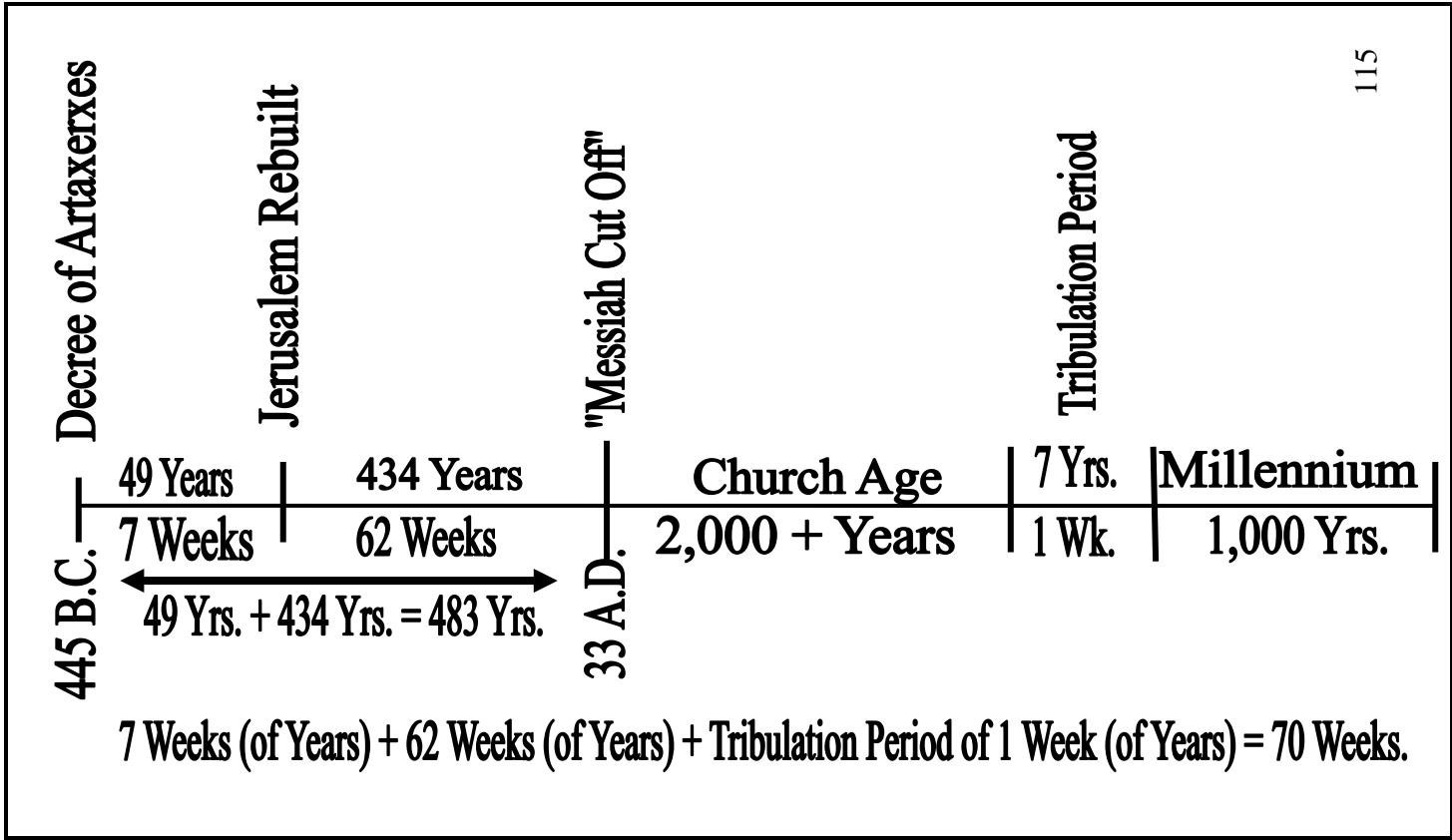

VIII. Prophecy

1. The 49 years, the 434 years, and the 483 years as shown on the diagram.

(a). The edict to rebuild Jerusalem by Artaxerxes in 445 B.C. unto the Messiah would cover a time span of 483 years.

“Know therefore and understand, that from the going forth of the commandment to restore and to build Jerusalem unto the Messiah the Prince shall be seven weeks, and threescore and two weeks: the street shall be built again, and the wall, even in troublous times.” (Daniel 9:25).

“And after threescore and two weeks shall Messiah be cut off, but not for himself: and the people of the prince that shall come shall destroy the city and the sanctuary; and the end thereof shall be with a flood, and unto the end of the war desolations are determined.” (Daniel 9:26).

(b). After the city was rebuilt, there would be 434 years to the Messiah being “cut off” (crucified). Therefore, subtracting 434 from 483, we know it took 49 years for the rebuilding of Jerusalem.

2. The fulfilling of the 483 years from the edict given in 445 B.C. to Christ being crucified has been illustrated as the following.

445 B.C. The Edict to Rebuild Jerusalem
33 A.D. Age Christ Died
4 Yrs. Calendar Off
1 Yr. Difference of Months

483 Yrs. Of Prophecy Were Fulfilled When Christ Was "Cut off," i.e. Crucified.

VIII. Prophecy

16. An Outline of Future Prophecy.

Due to many questions on this subject, we have included this brief outline overview of Future Prophecy. This is the basis for a future publication on prophecy, tentatively entitled...

"Blueprint For The Future"

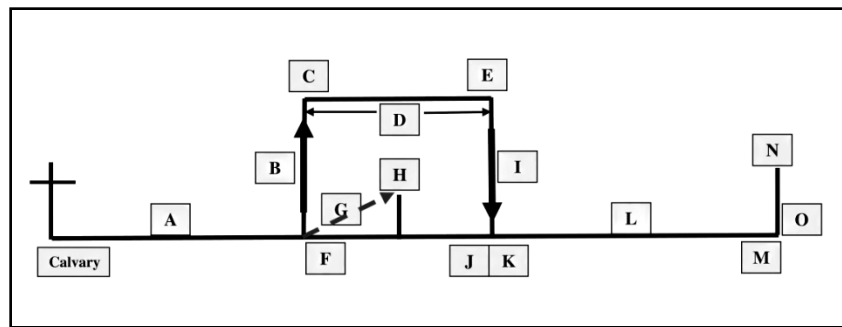

A. Church Age

1. The Building (Ephesians 2:19-22)
2. The Bride (Revelation 19:7,8)
3. The Church (Ecclesia, Assembly) (Ephesians 5:25)

B. Rapture (1 Thessalonians 4:13-18; 1 Corinthians 15:50)

C. Judgment Seat of Christ (2 Corinthians 5:10; 1 Corinthians 3:11-15)

D. Seven-year Tribulation Period (Daniel 9:25-27)

E. Marriage Supper of the Lamb (Revelation 19:7-9)

F. First Battle of Gog & Magog (Ezekiel, Chapters 38 and 39)

G. Antichrist's Rise To Power (Daniel 11:21 & 32; Dan. 8:23)

VIII. Prophecy

- H. Antichrist breaks his covenant with Israel.
 - 1. The Abomination of Desolation spoken of in Daniel 9:27; Matthew 24:15-20).
 - 2. Start of the Great Tribulation To The Last 3-1/2 years (Matthew 24:21,22).
 - 3. Antichrist Declares Himself to Be God (2 Thess.2:3,4).
 - 4. Starts His Control of The World As World Dictator (Revelation 13:16-18)

- I. Christ returns to the earth.
 - 1. Location, the Mount of Olives (Zechariah 14:4)
 - 2. Saints of God Will Come With Christ (Jude 14).
 - 3. Christ Upon His Throne (Matthew 25:31).
 - 4. Purpose, To Judge The Nations (2 Timothy 4:1).

- J. Battle of Armageddon (Rev. 14:15-20; 16:16; 19:15-21).

- K. Judgment of the Nations (Matt. 24:38-44; 25:32-46).

- L. Reign of Christ On Earth.
 - 1. Length - 1,000 years (Revelation 20:1,2).
 - 2. Peace (Isaiah 11:6-9).
 - 3. Nations will have to be represented in keeping the Feast of Tabernacles in Jerusalem once a year. (Zechariah 14:16-19).
 - 4. The Marriage Supper of The Lamb (Revelation 19:79)

- M. Second Battle of Gog And Magog (Revelation 20:8-10).

- N. Great White Throne Judgment (Revelation 20:11-15).

- O. New Heavens & New Earth (Revelation 21:1; 2 Peter 3:13).

VIII. Prophecy

17. Who Are the "Two Witnesses" In Revelation 11?

Question: Everyone has a guess at who the two witnesses of Revelation 11 are. Who are they, or does anyone know?

Answer:

I. The Introduction: This chapter is parenthetical from Verses 1-13, which is inserted between the 6th and 7th Trumpets of Judgment. The following may illustrate. These judgments begin back in Chapter 8:2,6.

"And I saw the seven angels which stood before God; and to them were given seven trumpets." (V.2)

"And the seven angels which had the seven trumpets prepared themselves to sound." (V.6).

1. First Trumpet – 8:7
2. Second Trumpet – 8:8-9
3. Third Trumpet – 8:10,11
4. Fourth Trumpet – 8:12,13
5. Fifth Trumpet – 9:1-2 (First Woe of 8:13)
6. Sixth Trumpet – 9:13-21 (Second Woe of 8:13)

Parenthetical Insert of Revelation 11:1-3. (The Two Witnesses).

7. Seventh Trumpet – 11:14-19 – (Third Woe of 8:1-13).

II. The Rebuilt Temple (11:1,2)

There are five temples: (1). Solomon's, (2). Zerubbabel's, (3). Herod's, (standing at the time of Christ and destroyed in 70 A.D. by Titus and the Roman Army), (4). Anti-Christ's Temple, spoken of here in Revelation 11, (5). Christ's Temple that will stand during the Millennium (Ezekiel, Chapters 40-48).

VIII. Prophecy

“And there was given me a reed like unto a rod: and the angel stood, saying, Rise, and measure the temple of God, and the altar, and them that worship therein.” (V.1)

“But the court which is without the temple leave out, and measure it not; for it is given unto the Gentiles: and the holy city shall they tread under foot forty and two months.” (V.2)

We know this is the rebuilt Tribulation Temple, as the Anti-Christ makes a covenant with Israel almost immediately after the Rapture (Daniel 9:27). A dear friend of mine for many years who had visited Jerusalem several times, and was a missionary to the Jewish people, had this to say concerning the Tribulation Temple. The Jewish Rabbis had revealed to him that the Temple structure was already pre-cut and needed only to be assembled, and which could be erected within a couple of months. The water supply and modern facilities are already there to flush the blood of their sacrifices to the Brook Kidron and on down to the Dead Sea.

Then, after 3 ½ years, the Anti-Christ breaks his covenant with Israel and seats himself in the Temple, declaring himself to be God. He is described in 2 Thessalonians 2:4.

“Who opposeth and exalteth himself above all that is called God, or that is worshipped; so that he as God sitteth in the temple of God, shewing himself that he is God.”

The Anti-Christ seeks to exterminate all Jews, if he can. (Read Matthew 24:15-22). According to Zechariah 13:8,9, only one out of three Jews will survive in their land. The Jews will be run out and the Gentiles will occupy their land, Jerusalem, and the area adjacent to the Temple in worshipping the Anti-Christ.

“But the court which is without the temple leave out, and measure it not; for it is given unto the Gentiles: and the holy city shall they tread under foot forty and two months.” --Revelation 11:2

VIII. Prophecy

This is the fulfillment as the Gentiles will totally dominate the Holy City (Jerusalem) and the court which is outside the Temple *“is given unto the Gentiles.”* They will tread under foot, i.e. occupy, for forty-two months. This is the last 3 ½ years of the Tribulation, before Christ comes in judgment and establishes His Kingdom for a 1,000 years.

III. The Two Witnesses of God: (Verses 3,4).

There are only two places in the Bible where these Two Witnesses are spoken of; here in Revelation 11 and also in Zechariah 4:3, 11-14.

“And I will give power unto my two witnesses, and they shall prophesy a thousand two hundred and threescore days, clothed in sackcloth.” (V.3)

“These are the two olive trees, and the two candlesticks standing before the God of the earth.” (V.4)

Here in Verse Three, God tells us that He will give supernatural power to His Two Witnesses, as we shall discover in Verses Five and Six. They will also prophesy. “Prophesy” in the Greek can be applied in two ways, depending on the context in which it is used. It can mean “giving forth the word of God,” or, “foretelling future events before they happen.” Here, both elements of prophesy would be included.

In other words, they would be witnessing to the lost concerning the Gospel, which is the death and resurrection of Jesus Christ for the payment of their sins. They would be explaining how the Rapture had been prophesied and fulfilled with all the Christians that had just disappeared. They would prophesy to Israel that the Book of Revelation has foretold that the Anti-Christ will break his promise of protection that he had

VIII. Prophecy

made. Therefore, they would be giving forth the word of God for salvation and prophesying what is yet to come; thus fulfilling the word “prophesy” to its fullest.

Their ministry is limited to 3 ½ years, described as 1,260 days. Jewish time is reckoned as 30 days to a month. Divide 30 into 1,260, and you will arrive at exactly 3 ½ years. They will then die a martyr’s death for their wonderful Savior, the Lord Jesus Christ. They will then leave their earthly visit

“to an inheritance incorruptible, and undefiled, and that fadeth not away, reserved in heaven for you.” (1 Peter 1:4).

Notice that Verse 4 is referring back to the prophecy first given in Zechariah 4:3, 11-14.

The power that God will give these Two Witnesses, spoken of in Verse Three, is described in detail in Verses 5,6.

“And if any man will hurt them, fire proceedeth out of their mouth, and devoureth their enemies: and if any man will hurt them, he must in this manner be killed.” (V.5)

“These have power to shut heaven, that it rain not in the days of their prophecy: and have power over waters to turn them to blood, and to smite the earth with all plagues, as often as they will.” (V.6).

In Verse Five, “*fire procedeth out of their mouth*” is not as one may think of, as fire coming out of a dragon’s mouth as we have all seen pictures of. It is a figure of speech; but, clarified in Jeremiah 5:14.

“Wherefore thus saith the LORD God of hosts, Because ye speak this word, behold, I will make my words in thy mouth fire, and this people wood, and it shall devour them.”

Should anyone attempt to hurt, or kill, these Two Witnesses, The Lord has given them the power to speak in the name of God, and the sentence of death will occur immediately.

VIII. Prophecy

There most always is a practical application to a spiritual truth. If you are a Christian who witnesses for the Lord, I am sure you have experienced as I have the anger, resentment, and hatred displayed by some of those who want nothing to do with our Savior.

I recall some time back that I was witnessing to a pharmacist, and stated that no amount of good works would merit eternal life; only faith in Jesus Christ who paid for our sins. Those words that I spoke ignited a fire of resentment and his response was, that he had been raised in his church, had been baptized, served as an altar boy, and was highly respected in the community. My message of grace through faith, not of good works, lit a fire of hate as he made it clear that I was never to bring up “religion” to him again!

Another example where the Lord uses an object as a figure of speech may be found in Revelation 1:16, where John is describing the Lord Jesus Christ and states that...

“...out of his mouth went a sharp twoedged sword...”

Do we see Christ, literally, with a sword sticking out his mouth? Of course not. It is a figure of speech that illustrates how deep the word of God can cut and penetrate, even to the soul and spirit. Hebrews 4:12 explains this figure of speech.

“For the word of God is quick, and powerful, and sharper than any twoedged sword, piercing even to the dividing asunder of soul and spirit, and of the joints and marrow, and is a discerner of the thoughts and intents of the heart.”

In the first part of Verse Six we are told of another power the Two Witnesses are given.

“These have power to shut heaven, that it rain not in the days of their prophecy...”

Their prophecy covers the first 3 ½ years after the Rapture. Can one imagine this world without rain for 3 ½ years. The lakes, rivers, streams and ponds would become stagnant and

VIII. Prophecy

polluted. Many of these will be dried up and there will be dead fish everywhere, with no fresh water from heaven. Crops cannot grow without water. Can one imagine the shortage of vegetables, beef, pork, chicken, etc., as all need water to survive. It is amazing how this fits in with Revelation 6:8, as a fourth of the population will die in the first 3 ½ years after the Rapture.

“And I looked, and behold a pale horse: and his name that sat on him was Death, and Hell followed with him. And power was given unto them over the fourth part of the earth, to kill with sword, and with hunger, and with death, and with the beasts of the earth.”

Two things stand out here, which contribute to a fourth of the population dying because of the famine caused by no rain falling for 3 ½ years. It is HUNGER and BEASTS. The Greek here is “therion” and is defined as, “a dangerous animal.” We have all heard from time to time about what happens when bears come into towns and villages in search of food. With no rain, the berries, chokecherries, acorns, and other natural foods will not be available. They will be forced to attack and eat anything alive, including humans, in lieu of starvation. Foxes, wolves, mountain lions, hyenas, etc., will kill and eat any dogs or cats that are available. Small children and even adults would be easy prey for a lion who is approaching starvation.

God’s Two Witnesses, by the power of God, have shut off Heaven’s “sprinkling system.” The Psalmist describes His power and purpose in a situation such as this in Psalms 107:33,34.

“He turneth rivers into a wilderness, and the watersprings into dry ground;” (V.33)

“A fruitful land into barrenness, for the wickedness of them that dwell therein.” (V.34)

Continuing in Verse Six, God has given His Two Witnesses “power over waters to turn them to blood.” This is literal, real blood! The Greek for “blood” is “haima” and is translated as

VIII. Prophecy

such in reference to the atoning blood of Christ, as it is in reference to human or animal blood. In other words, one day an enemy of God's Witnesses may be drinking fresh well water and the next day his cup is filled with literal blood! Thank the Lord we Christians will be watching all of this being fulfilled from Heaven, as we will be "*absent from the body and present with the Lord*" at the Rapture.

I believe it would be interesting to take a look back to the time when Moses was instructed by God to instruct Pharaoh to release His people, the Israelites, free from captivity. The first meeting with Pharaoh resulted in his demon-possessed men duplicating the miracles of Aaron. Here is the record.

"And Moses and Aaron went in unto Pharaoh, and they did so as the LORD had commanded: and Aaron cast down his rod before Pharaoh, and before his servants, and it became a serpent."

"Then Pharaoh also called the wise men and the sorcerers: now the magicians of Egypt, they also did in like manner with their enchantments." -- Exodus 7:10-11

The magicians also duplicated the second miracle by also turning water into blood. This is found in Exodus 7:20, 22.

"And Moses and Aaron did so, as the LORD commanded; and he lifted up the rod, and smote the waters that were in the river, in the sight of Pharaoh, and in the sight of his servants; and all the waters that were in the river were turned to blood." (V.20)

"And the magicians of Egypt did so with their enchantments: and Pharaoh's heart was hardened, neither did he hearken unto them; as the LORD had said." (V.22)

The third miracle of Aaron was also duplicated as recorded in Exodus 8:6,7.

"And Aaron stretched out his hand over the waters of Egypt; and the frogs came up, and covered the land of Egypt." (V.6)

VIII. Prophecy

“And the magicians did so with their enchantments, and brought up frogs upon the land of Egypt. (V.7)

One must realize that demons and demon-possessed men can only do supernatural things as God permits. When God restricts, their power is rendered useless and they are helpless, as seen in the last seven plagues. Notice, in the fourth plagues as an example of the rest.

“And they did so; for Aaron stretched out his hand with his rod, and smote the dust of the earth, and it became lice in man, and in beast; all the dust of the land became lice throughout all the land of Egypt.” (V.17)

“And the magicians did so with their enchantments to bring forth lice, but they could not: so there were lice upon man, and upon beast.) (V.18)

It is interesting that the Lord has revealed to us the names of these demon-possessed men who opposed Moses and Aaron. 2 Timothy 3:8 reveals their names.

“Now as Jannes and Jambres withstood Moses, so do these also resist the truth: men of corrupt minds, reprobate concerning the faith.”

Satan and his demons are as much alive today as they were in Moses' time. 2 Corinthians 4:3,4 explains this very well.

“But if our gospel be hid, it is hid to them that are lost:” (V.3)

“In whom the god of this world hath blinded the minds of them which believe not, lest the light of the glorious gospel of Christ, who is the image of God, should shine unto them.” (V.4)

Every Christian should be working as hard to present the Gospel as Satan is to pervert the Gospel.

Now, last of all in Verse Six, the Two Witnesses are given

VIII. Prophecy

additional power “to smite the earth with all plagues as often as they will.”

The words “plague” and “plagues” combined, appear 12 times in the book of Revelation. They are all from the same Greek word “plēgē.” It is defined as “a wound, a stripe, figuratively, a calamity.” In other words, this calamity could come to a person via an earthquake, a tornado, or anything from nature. Revelation, Chapters 15 and 16 speak of the Seven Last Plagues. The Two Witnesses could inflict grievous sores like those in Revelation 16:1; or hail stones inflicting bodily wounds like those in Verse 21. They could bring about the plague of a volcanic eruption; or any other plagues that would inflict their enemies **“AS OFTEN AS THEY WILL.”**

All of this demonstrates to mankind that God is in complete control over Satan and his followers. Satan can do nothing without God’s permission. Notice in Job, Chapter One, where we have God and Satan’s conversation recorded.

“And the LORD said unto Satan, Hast thou considered my servant Job...” (V.8a)

“Hast not thou made an hedge about him, and about his house, and about all that he hath on every side? Thou hast blessed the work of his hands, and his substance is increased in the land.” (V.10)

Satan’s Proposal:

“But put forth thine hand now, and touch all that he hath, and he will curse thee to thy face.”(V.11)

God’s Permission, Power, and Protection:

“And the LORD said unto Satan, Behold, all that he hath is in thy power; only upon himself put not forth thine hand. So Satan went forth from the presence of the LORD.” (V.12)

As a Christian we need to realize that Satan and his

VIII. Prophecy

followers can only go as far as God permits. God permitted Satan to test Job, who remained faithful to the Lord. God had confidence in His servant and Job had confidence in the Lord, even though he did not understand how it would all come out. He knew that he was going to live through it, as God had put a limit on Satan in his attack on Job.

“And the LORD said unto Satan, Behold, he is in thine hand; but save his life.” Job 2:6

God has given us His Word, the Bible. When we read His Word, study His Word, and are determined to yield our will to His will, it renders Satan helpless. One thing Satan cannot stand and hates the most is when a Christian “slaps him in the face” with the Word of God! As we look back on Job, we see that God rewarded his servant greatly for his faithfulness.

“So the LORD blessed the latter end of Job more than his beginning: for he had fourteen thousand sheep, and six thousand camels, and a thousand yoke of oxen, and a thousand she asses.” Job 42:12

How wonderful for a faithful Christian, upon entering their Heavenly home to be welcomed by the Lord with these words...

“His lord said unto him, Well done, thou good and faithful servant: thou hast been faithful over a few things, I will make thee ruler over many things: enter thou into the joy of thy lord.” Matthew 25:21

Revelation 11:7:

“And when they shall have finished their testimony, the beast that ascendeth out of the bottomless pit shall make war against them, and shall overcome them, and kill them.”

God permits the Beast (Antichrist) to kill them only after they have finished their testimony. Nothing can harm them until God has completed His message and warning. This demonstrates God’s power over Satan. Satan’s children will try to kill them;

VIII. Prophecy

but, will not be successful until God's work is finished. God's children have more power than their enemies. God permits their death only for His glory.

"For God hath not given us the spirit of fear; but of power, and of love, and of a sound mind."(V.7)

"Be not thou therefore ashamed of the testimony of our Lord, nor of me his prisoner: but be thou partaker of the afflictions of the gospel according to the power of God;" -- 2 Timothy 1:7-8

Revelation 11:8:

"And their dead bodies shall lie in the street of the great city, which spiritually is called Sodom and Egypt, where also our Lord was crucified."

Jerusalem is the capital of the world in God's sight; and yet, is so spiritually decayed it is compared to Sodom. *Yet*, God allowed His two witnesses to lie in the street and to be made a spectacle for a short time by these corrupt people.

The earth could be said to be the capital of the universe, as it was by God's power and for His glory that He created the earth and gave it unto men. (Psalms 115:16) The world today is rapidly approaching the condition of Sodom with its spiritual decay. Christians are, seemingly, killed and made a spectacle of by the world.

Jerusalem thought it could do away with God's Word by killing His witnesses. The world is trying to forget God in killing a Christian's witness by slander, mocking and deceit. God showed His power to and over the world in a resurrection of righteousness. The capital of the world and the capital of the universe are truly the Lord's and the fullness thereof, as He will sit upon the throne of David in Jerusalem as King of Kings and rule the world for a 1,000 years. Then it can be said that all

VIII. Prophecy

things have been put under His feet, for the world and all in it belong to Him.

Revelation 11:9: Television - "...see their dead bodies."

"And they of the people and kindreds and tongues and nations shall see their dead bodies three days and an half, and shall not suffer their dead bodies to be put in graves."

A Spiritual Application:

Christians should not give up when the lost seem to make a spectacle out of them and apparently try to "kill" their testimony. God has them in derision and laughs at them. (Psalms 2:4) Live so that when they speak evil of you, no one will believe them.

"He that sitteth in the heavens shall laugh: the Lord shall have them in derision."-- - Psalms 2:4

a. Trials will strengthen your faith (Romans 5:3-5)

"And not only so, but we glory in tribulations also: knowing that tribulation worketh patience;" (V.3) "And patience, experience; and experience, hope:" (V.4) "And hope maketh not ashamed; because the love of God is shed abroad in our hearts by the Holy Ghost which is given unto us." -- Romans 5:3-5

b. God will confound them through you for His glory.

"For after that in the wisdom of God the world by wisdom knew not God, it pleased God by the foolishness of preaching to save them that believe." 1 Corinthians 1:21

"And base things of the world, and things which are despised, hath God chosen, yea, and things which are not, to bring to nought things that are:" 1 Corinthians 1:28

c. We need, and pray for, God's strength in our lives daily. King David's prayer in Psalms 39:13 was..

VIII. Prophecy

“O spare me, that I may recover strength, before I go hence, and be no more.” Psalms 39:13

In other words, enable me to live that my life will cause men and women to think on eternity, so as to draw them to Christ, before I die.

Revelation 11:10:

“And they that dwell upon the earth shall rejoice over them, and make merry, and shall send gifts one to another; because these two prophets tormented them that dwelt on the earth.”

Great is the laughter and joy over an apparent victory of the Antichrist. It is only temporary, as shown in Psalm 50:15-23.

“And call upon me in the day of trouble: I will deliver thee, and thou shalt glorify me.” (V.15)

“But unto the wicked God saith, What hast thou to do to declare my statutes, or that thou shouldest take my covenant in thy mouth?” (V.16)

“Seeing thou hatest instruction, and castest my words behind thee.” (V.17)

“When thou sawest a thief, then thou consentedst with him, and hast been partaker with adulterers.” (V.18)

“Thou givest thy mouth to evil, and thy tongue frameth deceit.” (V.19)

“Thou sittest and speakest against thy brother; thou slanderest thine own mother's son.” (V.20)

“These things hast thou done, and I kept silence; thou thoughtest that I was altogether such an one as thyself: but I will reprove thee, and set them in order before thine eyes.” (V.21)

VIII. Prophecy

“Now consider this, ye that forget God, lest I tear you in pieces, and there be none to deliver.” (V.22)

“Whoso offereth praise glorifieth me: and to him that ordereth his conversation aright will I shew the salvation of God.” (V.23)

Sin is only enjoyed for a season...

“Choosing rather to suffer affliction with the people of God, than to enjoy the pleasures of sin for a season;” (Hebrews 11:25)

And then comes it's rewards! Psalm 10:1-16 and Psalm 9:17

“Why standest thou afar off, O LORD? why hidest thou thyself in times of trouble?” (V.1)

“The wicked in his pride doth persecute the poor: let them be taken in the devices that they have imagined.” (V.2)

“For the wicked boasteth of his heart's desire, and blesseth the covetous, whom the LORD abhorreth.” (V.3)

“The wicked, through the pride of his countenance, will not seek after God: God is not in all his thoughts.” (V.4)

“His ways are always grievous; thy judgments are far above out of his sight: as for all his enemies, he puffeth at them.” (V.5)

“He hath said in his heart, I shall not be moved: for I shall never be in adversity.” (V.6)

“His mouth is full of cursing and deceit and fraud: under his tongue is mischief and vanity.”(V.7)

“He sitteth in the lurking places of the villages: in the secret places doth he murder the innocent: his eyes are privily set against the poor.” (V.8)

VIII. Prophecy

“He lieth in wait secretly as a lion in his den: he lieth in wait to catch the poor: he doth catch the poor, when he draweth him into his net.” (V.9)

“He croucheth, and humbleth himself, that the poor may fall by his strong ones.” (V.10)

“He hath said in his heart, God hath forgotten: he hideth his face; he will never see it.” (V.11)

“Arise, O LORD; O God, lift up thine hand: forget not the humble.” (V.12)

“Wherefore doth the wicked contemn God? he hath said in his heart, Thou wilt not require it.” (V.13)

“Thou hast seen it; for thou beholdest mischief and spite, to requite it with thy hand: the poor committeth himself unto thee; thou art the helper of the fatherless.” (V.14)

“Break thou the arm of the wicked and the evil man: seek out his wickedness till thou find none.” (V.15)

“The LORD is King for ever and ever: the heathen are perished out of his land.” (V.16)

“The wicked shall be turned into hell, and all the nations that forget God.” Psalms 9:17

These could not see past the ends of their noses. This is the Antichrist's Christmas, as they are so happy that they are sending gifts to each other. Their gifts are a fool's folly, their Christmas is for the death of God's voice through the Two Witnesses. Our Christmas is for rejoicing in the birth of His voice through Christ. We rejoice in the Resurrection, for Christ ever liveth. To them only judgment, as they crucified Him; but, death could not hold Him, He arose and will return in judgment.

VIII. Prophecy

Revelation 11:11: A Christian's testimony.

"And after three days and an half the Spirit of life from God entered into them, and they stood upon their feet; and great fear fell upon them which saw them."

Verse 7 - attacked, apparently killed.

Verses 8 and 9 - made an open spectacle.

Verse 10 - the lost rejoice.

Illustration: Two boxers in a tournament. One fighting his way to what looks like an easy victory; but, as the fight progresses, his strength fails. He is "out of shape." A Christian can remain in the battle because he is "in shape"... spiritually sharp. He is trained and exercised in the Gospel. When the blows of tribulation come he slips the punches, blocking them with the shield of faith, even though the enemy has apparently won and is rejoicing. Our strength is renewed and we go on to victory. How? Through Christ. *"I can do all things through Christ which strengtheneth me,"* (Philippians 4:13).

Truly the lost stand in amazement when they see a Christian go through the trials rejoicing and come out with a victory in the name of Jesus Christ.

"If ye be reproached for the name of Christ, happy are ye; for the spirit of glory and of God resteth upon you: on their part he is evil spoken of, but on your part he is glorified." 1 Peter 4:14

Revelation 11:12:

"And they heard a great voice from heaven saying unto them, Come up hither. And they ascended up to heaven in a cloud; and their enemies beheld them."

VIII. Prophecy

Up is the only way for a child of God. He looks up to be saved; up in tribulation; up for the Rapture; up at death. *“Absent from the body, present with the Lord.”* 2 Corinthians 5:8.

Revelation 11:13:

Pronounces judgment, but the Christian already has been delivered from this day of wrath

- a. Noah, delivered from God’s wrath on the ungodly world. Genesis 4:17,18
- b. Lot, delivered from God’s wrath on Sodom and Gomorrah. Genesis 19:29
- c. Hell, Christians delivered from Hell. – John 5:24
- d. Rapture, Christians delivered from 7 years tribulation in the world. 1 Thessalonians 1:10

“And to wait for his Son from heaven, whom he raised from the dead, even Jesus, which delivered us from the wrath to come.”

The words “which delivered us,” in the Greek text, is future tense; NOT past tense. This phrase should have been translated “who delivers us” from the wrath to come, which is the Tribulation wrath as described in Revelation 6:17,18. Also Revelation 3:10.

- e. Enemies. Christians delivered from their enemies, as God wills and come out of the Tribulation alive. Others will be

VIII. Prophecy

permitted a Martyr's Crown for their faithfulness unto death (Revelation 20:4).

Note: Judgment came, many killed.

a. *"Affrighted and gave glory to God," "The fear of the Lord is the beginning of wisdom."* (Proverbs 9:10).

b. Judgment is always for God's glory. Why? It displays His justice. He is a just God. *"The wages of sin is death."* (Romans 6:23)

c. Sometimes it takes a death in the family to turn others to Christ.

Revelation 11:14:

"The second woe is past; and, behold, the third woe cometh quickly."

"Cometh quickly." Why? (10:6) *"No more delay."* The judgments of God will continue.

Revelation 11:15:

"And the seventh angel sounded; and there were great voices in heaven, saying, The kingdoms of this world are become the kingdoms of our Lord, and of his Christ; and he shall reign for ever and ever."

The world has laughed for years about Christ's coming back (2 Peter 3:3,4) and now it is a reality, at the end of the Tribulation.

"Knowing this first, that there shall come in the last days scoffers, walking after their own lusts," (V.3) "And saying, Where is the

VIII. Prophecy

promise of his coming? for since the fathers fell asleep, all things continue as they were from the beginning of the creation.” 2 Peter 3:3-4

Revelation 11:16,17:

“And the four and twenty elders, which sat before God on their seats, fell upon their faces, and worshipped God,” (V.16)

“Saying, We give thee thanks, O Lord God Almighty, which art, and wast, and art to come; because thou hast taken to thee thy great power, and hast reigned.” (V.17)

Four and twenty elders represent all the redeemed in giving God the glory. God’s Word, which the lost mocked, is now being fulfilled as they see the power of God displayed.

Revelation 11:18:

“And the nations were angry, and thy wrath is come, and the time of the dead, that they should be judged, and that thou shouldest give reward unto thy servants the prophets, and to the saints, and them that fear thy name, small and great; and shouldest destroy them which destroy the earth.”

“Nations were angry.” Why? Their sins are now being made manifest. That is why the lost rebel when they look to Christ. His light of righteousness illuminates their sinfulness. Any criminal is angry when caught, but this anger can turn to love when they are shown that Christ hates their sin; but gave them a full pardon at Calvary. He loved them enough to die for them. *“No greater love hath mortal man than for a friend to die.”* Therefore, by His death and resurrection, you can live, *“For he that believeth on Him hath everlasting life.”* (John 6:47)

a. Judgment...rewards to the saints...damnation to the lost. (Hebrews 9:27) *“...and then the judgment.”* (2 Thessalonians

VIII. Prophecy

1:7-9) This judgment takes place at the end of the Tribulation.

Revelation 11:19:

“And the temple of God was opened in heaven, and there was seen in his temple the ark of his testament: and there were lightnings, and voices, and thunderings, and an earthquake, and great hail.”

Activity in heaven as judgment is immediate.

1. Temple of God - Israel's temple was patterned after the one in heaven. (Acts 7:44 and Hebrews 8:5).

2. Ark of the Testament (Covenant). Israel's patterned after this.

3. Lightning and thundering, earthquake and hail, warning and judgment immediate.

4. Voices...show us the grave is not the end as Jehovah's Witnesses claim.

Summary: The Two Witnesses...who are they? Since they have power over their enemies with fire, death, control of the rain, turn water to blood, and all plagues (verses 5 and 6). It is conjectured by many that these two witnesses are either Moses and Elijah, or Enoch and Elijah.

a. MOSES AND ELIJAH: Moses, because of his plagues on Egypt and turning water to blood. (Exodus 7:19, 20). Elijah, because his prayer to God shut the windows of heaven for three and a half years. (James 5:17,18) This figure also corresponds

VIII. Prophecy

with the life of the two witnesses being shut out for three and a half days. (Revelation 11:9).

This is disproved by the fact Moses died and already had his heavenly body, for he was seen at the Mount of Transfiguration. (Matthew 17:3,4). A heavenly body cannot die and these two witnesses do, in their earthly bodies.

b. ENOCH AND ELIJAH: Some hold these are the two witnesses, because they have supposedly never died, (Enoch, Genesis 5:24) (Elijah, 2 Kings 2:11). This conjecture is based upon Hebrews 9:27,

“As it is appointed unto men once to die, but after this the judgment.”

Their physical bodies died before they reached Heaven, and the reason is, in 1 Corinthians 15:50,

“Now this I say, brethren, that flesh and blood cannot inherit the kingdom of God; neither doth corruption inherit incorruption.”

Therefore, their physical bodies have already died, once, after leaving the earth; but, prior to entering Heaven, the Kingdom of God.

c. ELIJAH: Another theory used to confirm Elijah as one of the Two Witnesses, is that he was prophesied to come before the Lord's return.

“Behold, I will send you Elijah the prophet before the coming of the great and dreadful day of the LORD:” Malachi 4:5

“The voice of him that crieth in the wilderness, Prepare ye the way of the LORD, make straight in the desert a highway for our God.” Isaiah 40:3

VIII. Prophecy

d. JOHN THE BAPTIST came to prepare the way of the Lord and “preached in the Spirit and power of Elijah.” This would have fulfilled these two prophecies.

“For this is he, of whom it is written, Behold, I send my messenger before thy face, which shall prepare thy way before thee.” Matthew 11:10

“And from the days of John the Baptist until now the kingdom of heaven suffereth violence, and the violent take it by force.” (V.12)

*“For all the prophets and the law prophesied until John.” (V.13)
“And if ye will receive it, this is Elias, which was for to come.”
Matthew 11:12-14 (17:10-13)*

John the Baptist did preach to Israel that Christ was their Messiah; but they rejected Him. In John 1:11 it is recorded that...

“He came unto his own, and his own received him not.”

The religious leaders of Israel hated Christ. Matthew 27:1 tells us that...

“When the morning was come, all the chief priests and elders of the people took counsel against Jesus to put him to death:”

Pilate addressed the mob when Christ was before him, stated that...*I am innocent of the blood of this just person, see ye to it.*” (Matthew 27:24).

“Then answered all the people, and said, His blood be on us, and on our children.” Matthew 27:25

Their request was granted, and has been for over the last 2,000 years.

God sent one witness, John the Baptist, to prepare the way for Christ’s first coming. After the Rapture, there are only seven

VIII. Prophecy

years before Christ returns to set up His Kingdom on earth. This time God uses Two Witnesses that speak of Christ's second coming, in the Spirit and power of Elijah, just like John the Baptist. Their death is only permitted by God for His glory, as they will be resurrected to life for the whole world to see.

There is a reason why their bodies lay dead for 3 ½ days. This is three full days and 12 hours into the fourth day; therefore, their bodies will be smelling, or stinking, as decomposition will have set in. In John 11:39, Martha's brother, Lazarus, had died and she told the Lord that, "*by this time he stinketh: for he hath been dead four days.*"

The proof of the death of the Two Witnesses was not only by sight; but, also by smell. This would dispel any skeptics who will later claim (as some did when Christ was crucified) that they have not really died; but, resuscitated after 3 ½ days.

Who are these Two Witnesses? God has not told us who they are. We will have to wait until we reach Heaven to be introduced.

Revelation 11 is History pre-written before it occurs, and so is the destiny of all humanity: Heaven or Hell. But the choice is the responsibility of each individual. Here is your choice, given from the Bible, God's Word.

"For God so loved the world, that he gave his only begotten Son, that whosoever believeth in him should not perish, but have everlasting life." John 3:16

"He that believeth on the Son hath everlasting life: and he that believeth not the Son shall not see life; but the wrath of God abideth on him." John 3:36

"Verily, verily, I say unto you, He that heareth my word, and believeth on him that sent me, hath everlasting life, and shall not come into condemnation; but is passed from death unto life." John 5:24

VIII. Prophecy

“These things have I written unto you that believe on the name of the Son of God; that ye may know that ye have eternal life, and that ye may believe on the name of the Son of God.” 1 John 5:13

18. Who Are the Two Olive Trees of Zechariah Four?

Zechariah 4:1-14

Question: I have been almost as confused about this passage of Scripture as Zechariah when he asked, "What are these two olive trees?"

Answer:

1. Zechariah and Haggai were contemporary and sent to the leaders and the people to finish building the temple they had started 15 years earlier. Satan had sent his opposition, which had caused the work to stop. (Ezra 4).

2. Joshua. From Haggai 1:12, we learn that he was the son of Josedech. In Ezra and Nehemiah, he is called Jeshua (Ezra 3:2). His grandfather, Seriah, was High Priest when Jerusalem was captured and the city destroyed in 586. He was executed at Riblah by Nebuchadnezzar and his father taken captive to Babylon. It was here that Joshua was probably born.

Ezra 2:64,65 states there were 49,897 that returned to Jerusalem in 536 B.C. On their arrival, Joshua would naturally have taken a leading part in the laying of the foundation of the temple in 535 B.C. Satan's opposition (Ezra 4; Zechariah 3:1,2) stopped the work for 15 years.

I. Introduction – Preliminary view of Chapter Four.

1. Chapter Four is God's Word to Zechariah for the leaders and the people in order to stir them up. God's protection is promised, as they are to start immediately to complete the building of their temple.

VIII. Prophecy

2. Chapter Four also contains a brief picture of three future prophecies given over 2500 years in advance.

a. The Jewish people rebuild the temple very soon after the Rapture. The religious but, unsaved Jews, are given by the godless world leaders, their protection and blessings by a false covenant that will be broken after 3-1/2 years.

b. Prophecy concerning the Millennial Temple and Kingdom Reign of Jesus Christ.

c. The Two Witnesses of God that prophecy against the false temple and worship.

II. “A Picture Is Worth a Thousand Words.”

There is much truth in the above statement; so, I thought a picture of the elements described in Zechariah, Chapter Four, might be of some help in understanding the prophecies of this chapter.

“And the angel that talked with me came again, and waked me, as a man that is wakened out of his sleep,” (1)

“And said unto me, What seest thou? And I said, I have looked, and behold a candlestick all of gold, with a bowl upon the top of it, and his seven lamps thereon, and seven pipes to the seven lamps, which are upon the top thereof.” (2)

“And two olive trees by it, one upon the right side of the bowl, and the other upon the left side thereof.” (3)

VIII. Prophecy

III. Visual Aids For Prophecy.

In this prophetic chapter, God uses various items as a figure of speech to illustrate various factual events. These items are: a golden candlestick, seven lamps, seven pipes, two golden pipes, a bowl, two olive trees and two olive branches. As one studies the Word of God, you will find that the FIG TREE is used in reference to Israel's national privileges. The VINE concerns Israel's spiritual privileges, and the OLIVE TREE represents Israel's religious privileges.



Now let us see if we can identify what this picture in Chapter Four illustrates:

1. *"A golden candlestick with a bowl on top."* (V.2) The Hebrew for "bowl" is "gullah" and defined as; "a fountain, bowl,

VIII. Prophecy

or globe, (all as round).” A candlestick extends up from its base. The bowl on top would indicate God overseeing everything in His creation. Isaiah 4:22 explains this.

It is he that sitteth upon the circle of the earth, and the inhabitants thereof are as grasshoppers; that stretcheth out the heavens as a curtain, and spreadeth them out as a tent to dwell in: (V. 22)

To whom then will ye liken me, or shall I be equal? saith the Holy One. (V. 25)

2. “The seven pipes extend from God and topped with seven lamps.” The Hebrew for “pipes” here in Verse Two is “mutsaqah” and means; “something poured out or cast in a mold. In Verse Twelve, the word “pipes” is a different Hebrew word with a different meaning, as will be explained later. Seven lamps and seven pipes is significant, as in the Bible, numbers have a meaning. Four is the number of the earth. Five is the number of grace. Six is the number of man, and seven is in reference to God’s divine completeness. In other words, God “sitteth upon the circle of the earth” to oversee all of His creation.

“The heaven, even the heavens, are the LORD’S: but the earth hath he given to the children of men.” - Psalms 115:16

Nothing in man can escape the eyes and knowledge of God Almighty.

“Neither is there any creature that is not manifest in his sight: but all things are naked and opened unto the eyes of him with whom we have to do.” - Hebrews 4:13

Speaking to Israel, the LORD has said”

“...for I know the things that come into your mind, every one of them.” - Ezekiel 11:5b

God has now waited fifteen years since the work on building

VIII. Prophecy

the temple had stopped. Satan and his followers had stopped the work after the foundations of the temple had been laid. God now lets Zechariah know that he will take care of Satan in Zechariah 3:1,2.

“And he shewed me Joshua the high priest standing before the angel of the LORD, and Satan standing at his right hand to resist him.” (1)

“And the LORD said unto Satan, The LORD rebuke thee, O Satan; even the LORD that hath chosen Jerusalem rebuke thee:...”(2)

Now, on to Zechariah 4:6, where the Angel continues to give God’s Word to Zechariah, who is to encourage Zerubbabel.

“Then he answered and spake unto me, saying, This is the word of the LORD unto Zerubbabel, saying, Not by might, nor by power, but by my spirit, saith the LORD of hosts.”

The leaders and workers will not have to fight Satan’s opposition with *their* power and might, or force. Satan’s opposition was so intense, and had mounted up to such a degree, as to be illustrated by the size of a mountain. God said, “I will remove all of Satan’s obstacles, so that the mountain will become as a plain and not one obstacle will remain,” as described in Zechariah 4:7.

“Who art thou, O great mountain? before Zerubbabel thou shalt become a plain: and he shall bring forth the headstone thereof with shoutings, crying, Grace, grace unto it.”

Zerubbabel is going to “bring forth the head stone” showing the leaders that he is starting the work to finish the building of God’s temple for the people. What excitement when the people see the work begun, as they shout for joy and cry out, “Grace, grace unto it.” For it is only by the Grace of God that it will be built. The Lord continues His prophecy of the temple in Verses 8,9, declaring that it will be completed.

VIII. Prophecy

“Moreover the word of the LORD came unto me, saying,” (8)

“The hands of Zerubbabel have laid the foundation of this house; his hands shall also finish it; and thou shalt know that the LORD of hosts hath sent me unto you.” (9)

This temple was not anything compared to Solomon’s temple, which was magnificent! But these Jewish people, who had been in captivity for 70 years to the nation of Babylon under Nebuchadnezzar, were thrilled to again have a place to worship.

“For who hath despised the day of small things? for they shall rejoice, and shall see the plummet in the hand of Zerubbabel with those seven; they are the eyes of the LORD, which run to and fro through the whole earth.” - Zechariah 4:10

To see the plummet, "PLUM" (a weight) "MET" (with line attached) in the hand of Zerubbabel, they knew the temple was going to be completed. It was not just talk; but, a reality.

a. *“With those seven,”* shows that with the help of the Lord, with His protection and guidance while overseeing everything, the temple was completed five years later.

b. *“Those seven, they are the eyes of the LORD, which run to and fro through the whole earth.”*

This last statement in Verse 10 is a basic statement, summarizing what the picture in Verse Two is illustrating, concerning the Omniscience, Omnipotence, and Omni-sapience of our Wonderful God who...

“...so loved the world, that he gave his only begotten Son, that whosoever believeth in him should not perish, but have everlasting life.” - John 3:16

VIII. Prophecy

“And we know that all things work together for good to them that love God, to them who are the called according to his purpose.” - Romans 8:28

5. The Future Prophecy, The Two Olive Trees.

And two olive trees by it, one upon the right side of the bowl, and the other upon the left side thereof.” - Zechariah 4:3

These are also described in Verses 11 to 14.

“Then answered I, and said unto him, What are these two olive trees upon the right side of the candlestick and upon the left side thereof?” (11)

“And I answered again, and said unto him, What be these two olive branches which through the two golden pipes empty the golden oil out of themselves?” (12)

“And he answered me and said, Knowest thou not what these be? And I said, No, my lord.” (13)

“Then said he, These are the two anointed ones, that stand by the Lord of the whole earth.” (14)

These are the same as the Two Witnesses, whose activities are described in Revelation, Chapter 11.

“And I will give power unto my two witnesses, and they shall prophesy a thousand two hundred and threescore days, clothed in sackcloth.” (V. 3)

“These are the two olive trees, and the two candlesticks standing before the God of the earth. (V. 4)

Their introduction, prophetically, was basically given over 2500 years ago in Zechariah, Chapter Four; as we will examine here. Then a little over 1900 years ago, specific details of their ministry during the Seven-Year Tribulation was prophesied by the Holy Spirit, through the Apostle John in Revelation, Chapter

VIII. Prophecy

11. This is what is known to Bible students as Progressive Revelation.

“For the prophecy came not in old time by the will of man: but holy men of God spake as they were moved by the Holy Ghost.”- 2 Peter 1:21

First, I would like to point out that Zechariah had no idea what the Lord was talking about concerning these two Olive Trees. Notice his words in Zechariah 4:11.

“What are these two olive trees...”

Then, again in Verse 12.

And I answered again, and said unto him, What be these two olive branches...”

And, again in Verse 13.

“And he (the Lord) answered me and said, Knowest thou not what these be? And I said, No, my lord.”

Daniel, like Zechariah, had many prophecies given him to record. Some were fulfilled; and many were yet for a future time. Daniel’s words to the Lord are in Daniel 12:8, and God’s response is in Verse 9.

“And I heard, but I understood not: then said I, O my Lord, what shall be the end of these things?” (8)

“And he said, Go thy way, Daniel: for the words are closed up and sealed till the time of the end.”(9).

The Apostle Peter had this to say about some of the Epistles penned by the Apostle Paul, by inspiration of the Holy Spirit.

VIII. Prophecy

“As also in all his epistles, speaking in them of these things; in which are some things hard to be understood, which they that are unlearned and unstable wrest, as they do also the other scriptures, unto their own destruction.” - 2 Peter 3:16

These Two Witnesses are described in Verse 3 and 11 as Olive Trees, not bushes or shrubs. Bushes and shrubs are easily moved, or cut down, but not trees. Trees have their roots deep in the ground. Described as trees, their spiritual roots are grounded in the Lord Jesus Christ, and His words. Psalm 1:1-3 would be descriptive of each of these Two Witnesses for the Lord in the Tribulation.

“Blessed is the man that walketh not in the counsel of the ungodly, nor standeth in the way of sinners, nor sitteth in the seat of the scornful.” (1)

“But his delight is in the law of the LORD; and in his law doth he meditate day and night.” (2)

“And he shall be like a tree planted by the rivers of water, that bringeth forth his fruit in his season; his leaf also shall not wither; and whatsoever he doeth shall prosper.”(3)

Zechariah 4:12 is a very interesting verse.

“And I answered again, and said unto him, What be these two olive branches which through the two golden pipes empty the golden oil out of themselves?”

Notice that the Two Witnesses were illustrated as two olive trees in Verses 3 and 11. Now, in Verse 12 they are spoken of as “olive branches.” The Hebrew for “branches” is “shibboieth” and means “a stream, (as flowing), a flood, to flow and to grow out of (as an ear of grain).” In other words, these Two Witnesses branch out everywhere! They are moving as a stream or river flows, witnessing everywhere, like a flood.

VIII. Prophecy

Notice the word “*through*” in Verse 12. The Hebrew word for “*through*” is “yad,” which is a prime word and is defined as, “a hand, the open one [indicating power, means, direction, and etc.]”

Notice the “*two golden pipes.*” The Hebrew for “pipes” here is “tnastarah” and means “to be hollow as a water spout, or hollow tube, or gutter.” Gold is a precious metal. Pipes are a hollow tube through which something can flow, and there are two of these. These simply, by object illustration, reveal to the world how precious their testimony is; flowing from their mouth and illustrated by their hand gestures.

Notice that they “*Empty the golden oil out of themselves.*” In other words, they are to speak, or give out everything that the Lord has given them to proclaim. They are to hold nothing back. The last thing given concerning these Two Witnesses is in Verse 14.

“Then said he, These are the two anointed ones, that stand by the Lord of the whole earth.”

Revelation, Chapter 11, gives the details and conclusion of their ministry.

IX. Psalms

1. What Are Some Guidelines for Study of the Psalms?

Question: Can you give me some information and guidelines in studying the Psalms. Also, what do the names in the titles mean?

Answer: The Hebrew title is “Tehilim”, meaning “praises or hymns.” It occurs only in the title of Psalms 145. The Greek title is “Psalomi, from which we get our word “Psalm.”

1. The Psalms contain 150 independent compositions. The Jews divided them into five books corresponding to the Five Books of Moses.

2. Psalms 1-42 correspond to Genesis, subject: man and creation. Psalms 43-72 correspond to Exodus (about Israel and redemption). Psalms 73-89 correspond to Leviticus (about worship and the temple). Psalms 90-106 correspond to Numbers (about our sojourn on the earth). Psalms 107-150 correspond to Deuteronomy (about praise and the word of God).

3. The Psalms are all lyrical, or songs adapted to musical instruments, and were all religious lyrics designed to be used in the sanctuary worship. Musical instruments accompanied the singing of the Psalms; such as the harp, psaltery, flute, pipe, horn, trumpet, timbrel and cymbal. Remember, King David had an orchestra of 4,000. (1 Chronicles 23:5).

4. The Psalms were written to be sung. Moses sang and taught the people to sing. (Exodus 15:1-21 and Deuteronomy 32:1-44). Israel sang. (Numbers 21:17). Deborah and Barak sang. (Judges 5). David sang. (2 Samuel 6:5,14,16). Hezekiah’s singers sang the Psalms with trumpets sounding (2 Chronicles 29:28-30). Nehemiah had singers at the dedication of the wall. (Nehemiah 12:42). When we study Psalms with an open heart and allow them to direct our lives, we will also sing with joy.

5. The Psalms are the only book that contains every

X. Psalms

psychological experience of a human being. The Psalms are the anatomy of all parts of the soul. They will touch every feeling or thought that anyone has ever had. For the Christian who needs comfort, understanding, compassion, direction, inspiration and hope, the Psalms are the answer. It has been called the masterpiece of Psychology!

6. Of the 283 New Testament quotations from the Old Testament, 116 are from Psalms.

7. Psalm 119 is the longest Psalm and the longest chapter in the Bible. Psalm 117 is the shortest, being the middle chapter of the Bible. Psalm 118:8 is the middle verse of the Bible.

If a person would only apply God's principles for a happy life, as found in the Psalms, the need for psychologists and psychiatrists would vanish. "It is better to trust in the Lord than to put confidence in man." (Psalm 118:8).

2. *What Are the Meanings of the Psalm Titles?*

Question: I am studying the Psalms and want to know the meaning of the words in the titles, and any other guidelines you can give.

Answer: Here is a brief definition of a few of the musical terms that appear in the titles of the Psalms. "Neginoth" means stringed instruments and appears in Psalms 4,6,54,55,61,67,76. Nehiloth" in Psalm 5 means "an accompaniment by wind instruments." "Shiggaion" in Psalm 7 is probably a line melody. "Gittith" in Psalms 8, 81,84 is a wine press or vintage song. "Aijeleth-Shakar" in Psalm 22 literally means "hind of the morning." It may be a time note or the name of a melody. "Maschil" in Psalms 32,42,44, 45,52-55, 74,78,88, 89,142 is thought to mean a didactic (to teach or give instruction), or reflective poem. "Jeduthun, in Psalm 39,77, a choir leader in David's day. "Shoshannim" in Psalms 45,69,80 means "lilies." It was possibly a spring song, or a metaphor for a woman's choir.

IX. Psalms

“Jonath-elem-rehokim” in Psalms 56 is probably the name of a tune. “Mahalath Leannoth” in Psalm 88 is a song for sickness.

1. David wrote many of the Psalms, as did various other writers. The titles are not absolute certainty of the authorship. In the titles the prepositions “of,” “to,” and “for” are the same Hebrew word. Therefore, a Psalm “of” David may be one he wrote, or which was written “for” David, or dedicated “to” David. The Psalms are recognized as the “Psalms of David”, primarily because he was the principle writer or compiler.

2. There are three key Psalms. Two, practical to the individual, are Psalms 1 and 23; and a third, prophetic concerning Christ, is Psalm 22.

3. I believe the key word for Psalms would be “Hallelujah”; that is, “Praise the Lord.” It occurs 13 times in six brief verses in Psalm 150; which is known as the “Hallelujah Chorus.” All of Psalms is directed to the Christian so he will joyfully “Praise the Lord!” Studying the Psalms is like mining for gold and digging up the unlimited wealth of God’s wisdom, grace, and direction which He gives to His children. Psalm 150 is the final “Doxology” for the whole book of Psalms; as is the final invitation for sinners to come to Christ found in the last chapter of the last book of the Bible (Revelation) in Verse 17c,

“...let him that is athirst come. And whosoever will, let him take the water of life freely.”

3. How Can the Imprecatory Psalms Be Explained?

Question: How can the “imprecatory” Psalms be explained, and exactly what does that word mean?

Answer: The word “imprecatory” means “to curse or pronounce evil upon.” Sometimes David, or others, would call down the most vivid kinds of judgment on their enemies.

X. Psalms

“Let his children be fatherless, and his wife a widow (9)...Let his posterity be cut off; and in the generation following (the second generation) let their name be blotted out.” (Psalm 109:9,13).

Other imprecatory Psalms are 35,69, and 137. The problem these Psalms pose is ethical. How can one love his enemies, yet engage in calling down curses upon them? Jesus said, “Love your enemies and pray for those who persecute you.” (Matthew 5:44). Several factors should be kept in mind when interpreting these Psalms:

1. First, the judgment called for is based on Divine Justice and not based on human grudges. David clearly affirmed in an imprecatory Psalm that he did not have personal ill feelings. He wrote in Psalm 109,

“...but I give myself unto prayer (for them). And they have rewarded me evil for good, and hatred for my love.” (Verses 4,5).

David did not hate his enemies, but loved them and prayed for them. He did, however, in the imprecatory prayer, commit them to the Justice of God for their due reward. The actions of David in relation to Saul are vivid proof that revenge was not a motivation behind his imprecatory prayers. David forgave Saul and, even on occasion, spared his life. (1 Samuel 24 and 26).

2. Judgment is expressed in the thought patterns of the day. For the Hebrews there was no sharp distinction made between the sinner and his sin; both were conceived personally. Further, a man and his family were considered a unit. They stood or fell together. Reference: Noah (Gen. 7:1,13) and Achan (Joshua 7).

3. The phenomenon of imprecation is not unique to the Old Testament. Jesus urged His disciples to curse cities that did not receive the Gospel. (Matthew 10:14; Luke 10:11,12). Jesus, Himself, called down judgment on Tyre and Sidon. (Matthew 11:20, 22. Paul declared “Anathema” (“accursed”) any who did not love the Lord Jesus. (1 Corinthians 16:22). Even the saints in Heaven during the Tribulation Period are pictured as beseeching

IX. Psalms

God for vengeance on those who killed the martyrs. (Revelation 6:9,10).

Imprecations are obviously not a primitive or purely Old Testament phenomenon. They are the reverse side of love; that is, prayers based on the Holiness and Justice of God, attributes which imply judgment on sin.

Even in these imprecations, one can see an aspiration for Christ. All judgment has been given to the Son. (John 5:22). Those who long for justice are really aspiring for Christ's Return to execute judgment.

“And to you who are troubled rest with us, when the Lord Jesus shall be revealed from Heaven with his mighty angels, (7)

In flaming fire taking vengeance on them that know not God, and that obey not the gospel of our Lord Jesus Christ: (8)

Who shall be punished with everlasting destruction from the presence of the Lord, and from the glory of his power; (9)

When he shall come to be glorified in his saints, and to be admired in all them that believe (because our testimony among you was believed) in that day.” (2 Thessalonians 1:7-10).

X. Reincarnation

1. *What Does The Bible Say About Reincarnation?*

Question: I hear a lot about reincarnation. What does the Bible say about this subject?

Answer: Yes, the Bible has a lot to say, in several ways, about the satanic teaching of reincarnation.

1. In Matthew 22:32, Christ is speaking and *states*

“I am the God of Abraham, and the God of Isaac, and the God of Jacob? God is not the God of the dead, but of the living.”

We know that the bodies of Abraham, Isaac, and Jacob are dead; but, not their souls and spirits, which are present with the Lord, are very much alive. God is God of the living. No reincarnation here!

2. In Matthew 17:1-3, we find Christ at the Mount of Transfiguration, along with Peter, James and John. Jesus was giving them a “preview of coming attractions,” as He would appear in His glorified body after His Resurrection. To strengthen their faith, He brought up Moses and Elijah from Paradise and carried on a conversation with them. Notice Matthew 17:3,

“And, behold, there appeared unto them Moses and Elias TALKING WITH HIM.”

Moses and Elijah had been dead for hundreds of years, i.e. their bodies; but, their souls and spirits were just as much alive, after their bodies had died, as they were when they were in their bodies. They are identified as the same persons after death as they were before death. No reincarnation here.

3. In Luke 23:42,43, we have the conversation between Jesus and one of the thieves on the cross. Verse 42 records the words of one of the thieves as he addressed Christ,

X. Reincarnation

“And he said unto Jesus, Lord, remember me when thou comest into thy kingdom.”

In Verse 43, Jesus makes it perfectly clear he is not going to be “reincarnated” as someone else or into the body of an animal. Here is the assurance that Jesus gave him for his faith.

“And Jesus said unto him, Verily I say unto thee, To day shalt thou be with me in paradise.”

No reincarnation here. You go directly to Paradise if you are saved; or, if you are an unbeliever, you go directly to Hell. Reincarnation is the Devil’s lie to deceive the simple minded who cannot bear the thought of an eternal Hell. Proverbs 14:15 says concerning the philosophy of men,

“The SIMPLE believeth every word: but the prudent man looketh well to his going.”

4. In Philippians 3:20,21, the believer is assured he will have his earthly body changed into a heavenly body like that of the resurrected body of our Lord Jesus Christ. There is no reincarnation of a person going into the body of another person, or living in the body of another person.

“For our conversation (Greek, politeuma, i.e. “citizenship”) is in heaven; from whence also we look for the Saviour, the Lord Jesus Christ: (20) Who shall change our vile body, that it may be fashioned like unto his glorious body, according to the working whereby he is able even to subdue all things unto himself.” - Philippians 3:20,21

In Revelation 21:4 the Lord describes the condition of a Christian, at home with the Lord, in his new, transformed body; without the sin nature he had with his earthly body.

“And God shall wipe away all tears from their eyes; and there shall be no more death, neither sorrow, nor crying, neither shall there be any more pain: for the former things are passed away.”

No reincarnation here.

5. God’s word refutes any thought of reincarnation in Hebrews 9:27.

X. Reincarnation

“And as it is appointed unto men ONCE to die, but after this the judgment.”

Reincarnation is diametrically opposed to the Word of God, in that it teaches; that upon death, the person goes into the lower body of an animal or another person; continually rotating, until they are purified from all sin. So, you would have many deaths; as the person’s soul passes from one body to another. The Bible says you die ONCE physically, and then the judgment. No reincarnation here.

6. 2 Corinthians 5:1,2 lets the Christian know that, when death comes to our earthly bodies, we have a new, glorified body, fit for our new home in Heaven.

“For we know that if our earthly house of this tabernacle (our physical bodies) were dissolved (death), we have a building of God, an house (our glorified bodies) not made with hands, eternal in the heavens. (1) For in this we groan, earnestly desiring to be clothed upon with our house (our new bodies) which is from heaven:”

No reincarnation here.

7. In 2 Corinthians 5:8 Paul states,

“We are confident, I say, and willing rather to be absent from the body, and to be present with the Lord.”

Not present in another physical body, whether animal or human! No reincarnation here.

8. In Revelation 6:9,10, John is shown a preview of coming events upon this earth. When the Rapture takes place, this will be the beginning of 7 literal years of tribulation and God’s judgment upon the earth. The last 3½ years are known as The Great Tribulation, such as the world has never experienced since the creation of mankind (Matthew 24:21). The last 3½ years are when the Antichrist falsely announces himself as God (2 Thesalonians 2:4), and will head up the one-world government requiring all to take the mark of “666.” (Revelation 13:17,18).

X. Reincarnation

Those that are Christians will refuse and, if apprehended, will be beheaded. (Revelation 20:4). It is these Christians, who die for their faith in Jesus Christ, which John witnessed in Revelation 6:9,10. Here is the record.

“And when he had opened the fifth seal, I saw under the altar the souls of them that were slain for the word of God, and for the testimony which they held: (9) And they cried with a loud voice, saying, How long, O Lord, holy and true, dost thou not judge and avenge our blood on them that dwell on the earth.”

In summary, these Christians who die do not go into another body, human or animal; BUT, directly to Heaven. No reincarnation here as this fallacy is *“vainly puffed up in the fleshly mind.”* (Colossians 2:18)

9. John 14:1-3 disintegrates reincarnation into nothing more than the imagination of the mind. For instance, reincarnation teaches that; with each reincarnation you purge away your sin until it is completely gone. This is the Devil’s delusion, denying the fact that Jesus Christ is the only one who could, and did, pay for the sins of the world. Christ’s words in John 14:1,2 are very clear.

“Let not your heart be troubled: ye believe in God, believe also in me. (1) In my Father’s house are many mansions: if it were not so, I would have told you. I go to prepare a place for you.” (2)

Christ did not go to Heaven to *prepare* the mansions for us. Notice that...

“In my Father’s house ARE many mansions...”

What Christ did was, go to the cross and shed His own sinless blood for the remission of sins for every individual. Ephesians 1:7 states it clearly,

“In whom we have redemption through his blood, the forgiveness of sins, according to the riches of his grace.”

The purpose of the cross was,

“...that where I am (Christ), there ye may be also.”

X. Reincarnation

In other words, we could live with Christ for all Eternity. No reincarnation here.

10. In Luke 16:19-31 we have a true, literal account, given by Christ Himself, of a saved and a lost man and their destinies after death. Seventh Day Adventists, Jehovah's Witnesses, Unity, Dianetics, L. Ron Hubbard, Herbert W. Armstrong, and etc., deny the existence of a literal Hell for the lost.

For example, Jehovah's Witnesses excuse this portion of Scripture, claiming it is only a parable. This false view is easily refuted by students of the Bible; as, no parable ever uses a proper name, and Lazarus' name is used here in Verses 20, 23, 24, 25. There is no exception to this rule in the Bible. In Verses 19-21 of this passage we have a rich man who was lost; and a poor man, named Lazarus, who was saved. In Verse 22, Jesus tells us what happened to Lazarus when he died,

“And it came to pass, that the beggar died, and was carried by the angels into Abraham's bosom...”

“Abraham's Bosom” is Jewish terminology for Paradise. It is the same place Jesus Christ, and the thief on the cross, went upon death. Notice Luke 23:43,

“And Jesus said unto him, Verily I say unto thee, To day shalt thou be with ME in Paradise.

No reincarnation here.

Next, Christ explains what happened to the rich man who died and was lost. Notice Verses 22b-24.

“...the rich man also died and was buried; (22) And in HELL he lift up his eyes, being in torments... (23) And he cried and said, Father Abraham have mercy on me, and send Lazarus, that he may dip the tip of his finger in water, and cool my tongue; for I am tormented in this flame.” (24)

No reincarnation here.

Some of these cults say that Hell is only here on the earth where we live. This is easily refuted by the fact that: (1). There

X. Reincarnation

are no Christians in Hell. (2). There are no churches in Hell. (3) And, the lost cannot be saved in Hell. Therefore a literal Hell is prepared for the Devil, his angels, and all of his children who have rejected the Lord Jesus Christ as their Savior. Matthew 25:41 explains this.

“Then shall he (Christ) say also unto them (the lost) on the left hand, Depart from me, ye cursed, into everlasting fire, prepared for the devil and his angels.”

Who Is Behind Reincarnation?

1. Two people, husband and wife, formed the cult religion of Unity, known today as the Unity School of Christianity. This cult religion, as we shall see, is no more Christian than the breakfast cereal “Grape Nuts Flakes” consists of flakes made from grapes and nuts. The founders of Unity were: Charles Fillmore, a man interested in spiritualism, Hinduism, and who also was an agnostic; and his wife, one Myrtle Fillmore, who had been raised a Methodist.

She moved from New England to Kansas City, Missouri, and was converted to Christian Science in 1887. She overcame several physical ailments after being converted to the Christian Science religion founded by Mary Baker Eddy. About 1893, both Charles and Myrtle became interested in the philosophy of Yogism, Hinduism, and reincarnation as endorsed and projected by one Swami Vevikananda of India. From here came the cult religion, Unity, incorporating the damnable philosophy of “reincarnation.”

Here are some of the things they do *not* believe.

1. They do not believe the Bible to be the inerrant word of God. They will not usually criticize the Bible, which would cause a disagreement with a Christian; but, will reinterpret the Scriptures, allegorizing them to fit their own philosophy.

2. They do not believe that God is a personal being. When they speak of God, they are not speaking of the God of Creation; nor of the God who gave His only begotten Son on the cross. It is

X. Reincarnation

summed up in their writings about their philosophy concerning the God of the Bible,

“God is not...a person, having life, intelligence, love, power. God is that invisible, intangible, but very real, something we call life.”
(“Lessons in Truth,” Lees Summit, MO, Unity School of Christianity, 1944, Pg.6).

3. They do not believe that Jesus Christ was God manifest in the flesh.

4. They do not believe in a literal Hell or a literal Heaven. Their teaching is that the only Heaven or Hell you will experience; will be received in accordance to how you behaved in each of your incarnations.

5. Since the cult, Unity, does not believe in a personal God who created this world nor its occupants; it, therefore, denies every doctrine that the Bible teaches. In other words, their teaching is, since there is no personal, intelligent, omnipotent, omniscient God; then, how could someone who doesn't exist write a book for us. Therefore, the Bible was only penned by different people expressing their own ideas and philosophies concerning the world and mankind.

God's warning concerning these cults is found in Colossians 2:8,

“Beware lest any man spoil you through philosophy and vain deceit, after the tradition of men, after the rudiments of the world, and not after Christ.”

Another woman you should know about, who believed the same concerning what we have previously stated at the beginning of #5 about the Unity cult. Her maiden name was Helena Petrovna and she was born in Ikaterinoslav, Russia, in 1831. At 17, she married a Russian general, named Blavatsky, who was much older than she. About 3 months later, she left her husband. For nearly the next 27 years she traveled extensively; you might say, world-wide, studying various mystical religions.

In 1875, she came to New York and founded The Theosophical Society, along with two of her faithful followers.

X. Reincarnation

One of her most Satanic writings is entitled “The Secret Doctrine,” which philosophy underlies the New Age Movement today. She is known as Madam Helena Blavatsky. In 1879 she left the United States en route to India, and in 1891, at the age of 60, died in London, England.

According to Blavatsky’s theology of the cult, Theosophical Society, there are 7 distinct planes in the Universe. The souls of people must progress through these by their reincarnations, en route to the Theosophist’s Devachan; their so-called “Heaven.”

What About Suicide As Influenced By Reincarnation?

There are different reasons and situations that contribute to the cause of one taking his own life. (There is an astounding amount of teenage suicide in America today.)

1. A teenager has experienced the alcohol, sex, and drug maze, concluding, “If this is all there is to life, then what is the use of living.” So, he, or she, takes his own life.

2. A teenager, whose mind has been scrambled by drug use, thinks he can fly. They go to the top of a building, jump out the window and “fly” to their death.

3. A teenager, hallucinating on drugs, goes to a bridge, jumps off and drowns; never thinking of the consequences.

4. I know of a case where a girlfriend broke off her relationship with her boyfriend. He went out and shot himself to death. (It is sad that people can’t realize that relationships can be temporary; but, death is permanent!)

5. Some have experienced such a “high” on drugs that they continually crave the experience. This has led to many deaths by OD.

6. Despondency over accumulated debts to the point where there appears to be no way to resolve the situation. The home is about to be foreclosed on. The car is about to be repossessed and their wages are about to be garnisheed. Suicide results as they picture themselves enclosed in a vault with no door of exit.

These are but a handful of situations that could lead to one

X. Reincarnation

taking his own life.

NOW, I would like for you to apply to the above situations the damnable, satanic philosophy of reincarnation, as projected by the cults of Unity School of Christianity, The Theosophical Society, and the New Age Movement. Remember, they have “brainwashed” the gullible that there is NO HELL; and, that no matter what you have done previously, upon death you will be reincarnated into another body. In other words, with each incarnation you will do better until all sin is purged. Believing this, you have extinguished the fear of death in your mind. I wonder...how many suicides have been influenced by this kind of humanistic philosophy?

Satan Is Behind It All!

In John 8:44 we are told that Satan is a murderer and a liar and that

“...your adversary the devil, as a roaring lion, walketh about, seeking whom he may devour.” (1 Peter 5:8).

GOD has proved His love for you in John 3:16.

“For God so loved the world, that he gave his only be gotten Son (Jesus Christ), that whosoever believeth in him should not perish, but have everlasting life.”

Not, “have reincarnation!”

XI. Repentance

1. *The "Case of The Pride-Filled Church"*

2 Corinthians 7:10

Question: When I talk with certain groups teaching Lordship Salvation, they give me this verse. What is the actual meaning of this verse? I quote:

"For godly sorrow worketh repentance to salvation not to be repented of: but the sorrow of the world worketh death." (2 Corinthians 7:10)

Answer: When studying the Bible, a person should consider a Bible passage in its entire context; which, in this case, is 2 Corinthians 7:8-11, plus supporting passages. In order to understand the passage, it is imperative to acknowledge a little background of events. This will help.

- a. Paul is writing to Christians. (1 Corinthians 1:1-6)
- b. The Christians were carnal, not spiritual. (1 Corinthians 3:1-3)
- c. Prior to 1 and 2 Corinthians, Paul had written the church a letter, which is referred to in 1 Corinthians 5:9,10; and which God did not include in the Bible.

"I wrote unto you in an epistle not to company with fornicators: (9) Yet not altogether with the fornicators of this world, or with the covetous, or extortioners, or with idolaters; for then must ye needs go out of the world." (1 Corinthians 5:9-10)

- d. Earlier, Paul had received some bad news concerning this, as recorded in 1 Corinthians 5:1-2

"It is reported commonly that there is fornication among you, and such fornication as is not so much as named among the Gentiles, that one should have his father's wife. (1) And ye are puffed up, and have not rather mourned, that he that hath done this deed might be taken away from among you." (1 Corinthians 5:1-2)

In Verse 2, their attitude was carnal, as they were "*puffed up*" (Gr. *phusioo*, "pride filled"), *and have not rather mourned*" (no godly sorrow for condoning this man's sin)." In the rest of the

XI. Repentance

chapter, from Verse 3 to 13, Paul rebukes them and instructs them on how to handle this situation in the church. This Epistle to the Corinthians was written in about 56 A.D.

Now, about 57 A.D., Paul writes the Epistle of 2 Corinthians. Prior to this, Titus had visited the Corinthian church to ascertain their feelings toward Paul, and to see if they had followed his instructions given in 1 Corinthians, Chapter 5, concerning the fornicator in the church. Titus then reported back to Paul of the good news from Corinth, as Paul states in 2 Corinthians 7:6,7.

"Nevertheless God, that comforteth those that are cast down, comforted us by the coming of Titus; (6) And not by his coming only, but by the consolation wherewith he was comforted in you, when he told us your earnest desire, your mourning, your fervent mind toward me; so that I rejoiced the more." (2 Corinthians 7:6-7)

Now with this background, we will be able to understand more clearly the meaning of Verses 8-11, where three Greek words are translated the English word "repent." Now, let us examine each verse, beginning with Verse 8, which deals with the carnal nature.

"For though I made you sorry with a letter, I do not repent, though I did repent: for I perceive that the same epistle hath made you sorry, though it were but for a season." (8)

In 2 Corinthians 7:4, Paul said *"Great is my boldness of speech toward you."* This is referring to his rebuke of them for their pride and lack of godly sorrow, or mourning, concerning the fornicator as recorded 1 Corinthians, Chapter 5. Then in 2 Corinthians 7:8, the word "repent," in both cases, is the Greek "metamelomai" and means "regret." Now, Paul is referring to his previous epistle, reference Chapter 5, which would read this way.

"I do not repent (Greek, "regret") writing to you, though I did repent (Greek, "regret") that it made you sorry and you got your feelings hurt because of your pride, though it were but for a season."

Verse 9 deals with the spiritual nature.

XI. Repentance

"Now I rejoice, not that ye were made sorry, but that ye sorrowed to repentance (metanoia): for ye were made sorry after a godly manner, that ye might receive damage by us in nothing." (2 Corinthians 7:9)

"Now I rejoice, not that ye were made sorry;" which in street language means, "I am not happy that your pride got offended." Now, after their old nature got its feelings offended, the Holy Spirit inspired Paul's Epistle in 1 Corinthians 5, to illuminate their minds to obey God's will concerning the fornicator in their church. Therefore, they "sorrowed to repentance," which caused Paul to rejoice. Please notice that "repentance" in Verse 9 is a different Greek word than "repent" in Verse 8.

"...Ye sorrowed to repentance..." "Repentance" here is from the Greek word "metanoia." "Meta," which means "after, implying change; and "noeo," "to perceive." Simply put, this means "to change your mind about what you previously thought. This they did, which inspired Paul to rejoice and write *"that you might receive damage (Greek "zemioo" or, "loss") by us in nothing."* Paul was rejoicing that they were made sorry after a godly sort, that they suffered no spiritual loss; nor any further reprimand.

Verse 10 deals with the difference between the old nature ("sorrow of the world") and the new nature ("godly sorrow").

"For godly sorrow worketh repentance to salvation not to be repented of: but the sorrow of the world worketh death." (2 Corinthians 7:10)

This verse is still dealing with the change of attitude of the church concerning the fornicator within. The situation had to be corrected by one of two ways. Either repentance by the fornicator; or expulsion from the church. By the stand the church took, the fornicator was converted, as recorded in 2 Corinthians 2:1-10.

A key word in 2 Corinthians 7:10 is "salvation," which means "deliverance;" and should have, by the context, been translated as such. In other words, as a result of Paul's rebuke in 1 Corinthians 5, the church leaders changed their mind to

XI. Repentance

deliverance. What were they delivered from?

- a. Condoning the sin of fornication within the church.
- b. Disobeying Paul's first letter (not in the Bible); and 1 Corinthians 5:9, warning not to have company with fornicators.
- c. The pride and arrogance that could have destroyed the church.
- d. Influencing other Christians to compromise and tolerate the sinful act within the congregation.
- e. The chastening of the Lord.

The word "salvation" denotes "deliverance, and preservation of material, and temporal deliverance;" as well as "salvation," depending on the context. The reason "salvation" is an incorrect rendering here, is that the Corinthians were already saved. Therefore, this is not speaking about their salvation; but, deliverance from their pride in condoning a fornicator, to that of godly sorrow as a result of Paul's letter rebuking them.

The word for "repented" in Verse 10 is the Greek "ametameletos," which means, "un-regretted, without change of purpose, or irrevocable." Please note the verse with the Greek meanings.

"For godly sorrow (conviction) worketh (or leads to) repentance (Greek, a change of mind, the spiritual mind) to salvation (deliverance) not to be repented (never to be revoked or regretted) of: BUT the sorrow of the world (carnal mind) worketh death." (2 Cor. 7:10)

Paul now sums up everything, in 2 Corinthians 7:11, the church was delivered from by changing a carnal decision, based on pride, to a spiritual decision, based on the Word of God.

"For behold this selfsame thing, that ye sorrowed after a godly sort, what carefulness it wrought in you, yea, what clearing of yourselves, yea, what indignation, yea, what fear, yea, what vehement desire, yea, what zeal, yea, what revenge! In all things ye have approved yourselves to be clear in this matter."

"...Clear in this matter." Case closed in the matter of tolerating a fornicator in the church!

XII. Resurrection

1. *How Could Jonah Live After Being Swallowed By A Whale*

Question: My friend says he can't take the Bible seriously because of the Book of Jonah. He feels there is no way possible Jonah could have been swallowed by a whale and, after three days, live. I tell him there's no way to humanly figure it out—it's a miracle. Who is right?

Answer: You are both right! Jonah did *not* live for three days in the "whale's" belly—he died! And it *was* a miracle. Two points should be emphasized. (1). The miraculous is obvious from the beginning. *"The Lord had prepared a great fish to swallow up Jonah."* (Jonah 1:17). (2). Our Lord explicitly stated in Matthew 12:40 that this was a fact!

"For as Jonas was three days and three nights in the whale's belly; so shall the Son of man be three days and three nights in the heart of the earth. (Also see Jonah 1:17b.)"

What was the miracle that was illustrated by this great incident in the life of Jonah? Jonah's being swallowed up by the great fish was an example of the Resurrection of Christ, who would be crucified, buried, and raised up on the third day. *"For as Jonas...so shall the Son of man be..."* Christ did not live in the grave for three days and then emerge. He *died* as the payment for the sin of all mankind.

The fact that Jonah died is proved by the biblical language.

"Then Jonah prayed to the Lord...out of the fish's belly." (Jonah 2:1)

"Belly" is the Hebrew word "me-ah" or "abdomen." In Jonah 2:2, Jonah states

"...out of the belly of hell cried I..."

Here "belly" is from the Hebrew word "betan" and means "a hollow place," and "hell" is "sheol." Now Jonah's body is in the

XII. Resurrection

belly of the fish and his soul and spirit is in the hollow place of Sheol. This is the same location as described in Luke 16:19-31 (from the Greek "Hades"); with Paradise on one side and Torment on the other, with a great gulf between and; until after the Resurrection of Christ, was the place where the soul and spirit of those deceased would await their Resurrection. Not "soul sleeping," but the lost and saved were fully conscious, able to feel, see, reason, and speak as evidenced by Luke 16.

When Christ's body was in the grave for three days and nights, he was in the Paradise side of Sheol/Hades. (Acts 2:27; Psalm 16:10) At Christ's Ascension, He emptied Paradise (Ephesians 4:8-10), and Paradise is now in the immediate presence of God. We find the Apostle Paul was "*caught up to the third heaven...into paradise.*" (2 Corinthians 12:1-4) During this present church age the saved who die are "*absent from the body...present with the Lord.*" (2 Corinthians 5:8). Torment, with its fully conscious, unbelieving inhabitants, awaits the final judgment of Revelation 20:13.

There are many accounts in the Bible of those who were brought back to life in a physical body like Jonah; but, eventually they died, as did Jonah in his time. It was a temporary thing, as this physical life is. If we believe that Jesus died to pay for our sins, God promises us everlasting life.

"For God so loved the world, that he gave his only begotten Son, that whosoever believeth in him should not perish, but have everlasting life." (John 3:16)

2. *Was Christ Before Pilate At the Sixth Hour; or On the Cross?*

John 19:14,15 Vs. Matthew 27:44,45

Question: In my study of the harmony of the Gospels, I have run into a real snag. In John 19:14,15, Christ was before Pilate at about the sixth hour; but, in Matthew 27:44,45, Christ was on the cross at the sixth hour. How could He be both places at the same

XII. Resurrection

time?

Answer: Remember one important thing. The Jews reckoned their time of day from 6 a.m. to 6 p.m. to 6 a.m. The Roman time was reckoned from midnight to noon to midnight, the same as we do today. Matthew, Mark, and Luke all use the Jewish time; whereas, John uses the Roman time. From John 18:28 to 19:15, Christ had been all night before Pilate and it was "*about the sixth hour*" (i.e. the Roman time of 6 a.m. in the morning.). Then, in John 19:16, Christ was delivered to be crucified. Now Matthew 27:45,46; Mark 15:33,34; and Luke 23:42-46 all record, *in harmony*, that Christ is on the cross at the sixth hour, which would be twelve o'clock noon in Jewish time. (The sixth hour from the Jewish beginning of day at 6 a.m. would be noon.)

The Gospel of Mark gives the complete picture concerning the time. Mark 15:25, Christ was put on the cross at the third hour (9 a.m.). In Verse 33, at the sixth hour or noon, there was darkness over the whole land. Then, in Verses 34-37, He submitted himself unto death at the ninth hour (3 p.m.).

There is no contradiction at all. Always remember Matthew, Mark, and Luke use the Jewish time and John uses the Roman time. This shows the Gospels are in perfect harmony as all Scripture is given by the "inspiration of God." (2 Timothy 3:16).

3a. The Fallacy of "Good Friday" and "Easter Sunday"

Question: If Christ was taken from the cross on the afternoon of "Good" Friday and was out of the tomb by early "Easter" Sunday morning, how can you get 72 hours?

Answer: The short answer is, "You can't!" Let me explain. The Lord Jesus had to spend 72 hours in the grave to fulfill Scripture.

"For as Jonas was three days and three nights in the whale's belly, so shall the Son of man be three days and three nights in

XII. Resurrection

the heart of the earth.” (Matthew 12:40, cf. Jonah 1:17).

The Lord, himself determines how many hours there are in a day. “...are there not twelve hours in a day?” (John 11:9). If there are twelve hours in a day, there are twelve hours in a night. Thus, three days and three nights equal 72 hours.

Christ had already been resurrected, between 3:00 P.M. and 6:00 P.M., on Saturday. (The following is the text from a book entitled, *Three Important Questions* by the author.)

Three Important Things To Remember:

A. The Jewish day was divided at 6:00 P.M.; the old day ended and the new day began. For example, look at “Diagram A” and you will see that Wednesday actually ended at 6:00 P.M. on Wednesday. Thursday actually began at 6:00 P.M. on Wednesday. Friday began at 6:00 P.M. on Thursday and etc. The Romans began their new day at Midnight.

B. The Sabbath Day is always on Saturday, not Sunday. Sunday is the first day of the week. Paul gave instructions to the Christians to “...lay by him in store, as God had prospered him, on the first day of the week.” (Sunday, 1 Corinthians 16:2). The disciples always came together to break bread and fellowship on the first day of the week (Sunday, Acts 20:7).

C. The Jewish day ran from “even” (evening) until “even” (evening).(Lev. 23:32). The time being set at approximately 6:00 P.M.

The Resurrection Day:

A. Matthew 12:40. The Lord Jesus had to spend 72 hours in the grave to fulfill scripture. *“For as Jonas was three days and three nights in the whale’s belly, so shall the Son of man be three days and three nights in the heart of the earth.”* (See Jonah 1:17).

B. John 11:9. The Lord, Himself, determines how many hours in a day, “...are there not twelve hours in a day...? If there are twelve hours in a day, there are twelve hours in a night. Thus,

XII. Resurrection

three days and three nights equal 72 hours.

C. Matthew 28:1. *"In the end of the Sabbath, as it began to DAWN toward the first [day] of the week, came Mary Magdalene and the other Mary to see the sepulchre."*

1. The *"end of the Sabbath"* is the last few hours before the Sabbath ends and the first day of the week, Sunday, begins. Dawn is the Greek word "epiphosko" and means to "draw on." It was "drawing on" or approaching the first day of the week. This first day of the week is Sunday, which actually began on Saturday at 6:00 P.M. (Luke 23:54) .

2. Remember, the first arrivals were there before 6:00 P.M. on Saturday, the Sabbath, and the tomb was already empty. *"He is not here, for He is risen as He said."* (Matthew 28:6) .

Refer to DIAGRAM A:

Notice letter "b." This is when the Lord has arisen. As we have seen, these are the last hours before the Sabbath ends at 6:00 P.M. When the first arrivals reached the tomb, Christ had already been resurrected, between 3:00 P.M. and 6:00 P.M. on Saturday.

Looking backward, from **"d"** to **"c"** is 24 hours, from **"c"** to **"b"** is 24 hours, and from **"b"** to **"a"** is 24 hours. The time of His burial is "a," which would have been in the last hours of Wednesday, between 3:00 P.M. and 6:00 P.M. This is the only way scripture could be fulfilled, as Christ had to be three days and three nights in the heart of the earth, thus seventy-two hours. A far cry from "Good Friday" and "Easter Sunday", which are strangers to the Word of God!

So...if you count backwards.

3 P.M. Saturday to 3:P.M. Friday = 24 hours.

3 P.M. Friday to 3 P.M. Thursday = 24 hours.

3 P.M. Thursday to 3 P.M. Wednesday = 24 hours.

Three times twenty-four hours = 72 hours.

XII. Resurrection

The time of Christ's death and burial would have been in the last hours of Wednesday (the Passover Sabbath), between 3 and 6 P.M. This is the only way Scripture could be fulfilled, as Christ had to be three days and three nights in the heart of the earth, thus seventy-two hours.

NOW...the central truth is this! "*And if Christ be not risen, then is our preaching vain, your faith is also vain.*" (1 Corinthians 15:14). BUT, we praise the Lord! He DID rise from the grave, showing God accepted His payment for the sins of the world.

"For God so loved the world, that he gave his only begotten Son, that whosoever believeth in him should not perish, but have everlasting life." (John 3:16)

SO...every Sunday is Easter Sunday in our church, as we celebrate the greatest event of all History!

3c. Explanation of the Time Chart of the Events During the Trial and Conviction of Jesus: Diagram B

1. Passover, or Last Supper: Our Savior was crucified on Wednesday, which actually began at 6:00 P.M. on Tuesday. The Passover Feast was prepared in the last hours of Tuesday, between 3:00 P.M. and 6:00 P.M. It was then partaken of at the Last Supper, just after 6:00 P.M.; or the beginning of Wednesday. Therefore, the feast was observed in the early hours of Wednesday; and Christ partook of the Passover on the same day He gave Himself to be the crucified Passover Lamb. This is substantiated by Matthew 26:19-21.

A. Verse 19: Preparation of the Passover (Tuesday),

"And the disciples did as Jesus had appointed them; and they MADE READY the Passover."

XII. Resurrection

B. Verse 20: Parting of Days (“even,” 6:00 P.M.)

"Now when EVEN was come, He sat down with the twelve."

C. Verse 21: Partaking of the Passover (Wednesday),

"And as they DID EAT, He said, Verily I say unto you, that one of you shall betray me."

For further information on the Passover, read Exodus 12 and Leviticus 23. The Feast of Passover and Unleavened Bread were actually two feasts in one. Passover began on the 14th day of Nisan (Abib) and continued through the next day, on which began the Feast of Unleavened Bread. This feast continued for seven days, making a total of eight days for the combined feasts. A lamb without blemish was selected and sacrificed. This was in type of the Lord Jesus Christ who sacrificed Himself for our sins. 1 Peter 1:18, 19, and John 1:29,

..."Behold, the LAMB of God which taketh away the sin of the world."

2. Praying in the Garden: It is called “Gethsemane” in Matthew 26:36. It was located on the Mount of Olives and was a place Jesus customarily resorted to (Luke 22:39). Christ was in the Garden within the first few hours of Wednesday, which began at 6:00 P.M. Three times our Lord prayed,

"...O my Father, if it be possible let this cup pass from me: nevertheless not as I will, but as thou wilt." (Matthew 26:39, 42, 44).

The significance of this is—Christ had been with the Father for all time and eternity. He was saying, "If there be a way we would not be separated while I am paying for the world's sin, then let it pass." He did not want to bypass paying for sin; but to bypass separation from the Father in doing so. Christ suffered separation from the Father; so you and I, by faith, would never be separated from Him.

3. The Arrest: Details of the arrest are only given in John. The arrest took place at night (Matthew 26:31) as the arresting

XII. Resurrection

officers came forth with "...lanterns and torches and weapons." (John 18:3). This was probably between 6:00 P.M. and Midnight, the early hours of Wednesday.

A point of interest concerning Judas being saved or lost! In Matthew 27:3 it is said that Judas "*repented himself*," therefore, some believe he was saved. The answer lies in the meaning of the Greek word translated in our English, "repented." The Greek word for "repented" in Matthew 27:3 is "metamelomai" and means "sorrow" or "regret." The Greek word translated "repent," when used in reference to salvation, is always metanoia and means "a change of mind." Judas was (metamelomai) sorry when he saw that Christ had been condemned to death (Matthew 27:3); but he never (metanoia) changed his mind about Christ being his Savior. Judas died a lost man.

4. First Taken to Annas, the High Priest: (John 18:13) "*And led him away to Annas first...*" Remember Annas and Caiaphas were co-reigning high priests (Luke 3:2). Prior to Christ's arrest, they had conspired against Christ to kill Him (Matthew 26:3,4). It was Annas and Caiaphas whom Judas dealt with for 30 pieces of silver (Matthew 26:14,15). Their hatred was intensified when Malchus' ear was cut off by Peter, as they were attempting to arrest Christ (John 18:10). Malchus was related ("kinsman") to either Annas or Caiaphas (John 18:26). After a preliminary hearing, Annas bound Christ and delivered him to his son-in-law, Caiaphas.

5. Appears Before Caiaphas: Christ was brought into the palace of Caiaphas, (Matthew 26:57,58). The palace was not the temple, but the dwelling place of an important official. His treatment of Christ is described in verses 59-68. These events probably took place sometime between Midnight and 3:00 A.M. on Wednesday. The late night and early morning hours were cold, as the servants and officers had built a fire to warm themselves, while the high priest was conducting the pretense of a trial (John 18:18).

XII. Resurrection

6. Peter's Three Denials of Christ: These are recorded in Matthew 26:69-75, also in Luke 22:57-62. Peter had bragged about himself in Matthew 26:33,35 and Luke 22:33,34. A few hours later, he denied Christ three times. His denials were overheard!

"And the Lord turned, and looked upon Peter. And Peter remembered the word of the Lord...Before the cock crow, thou shalt deny me thrice... (61) And Peter went out and wept bitterly." (Luke 22:61,62).

After the Resurrection, the Lord gave him opportunity to confess Him three times (John 21:15-17). Even after Peter's denial, Christ used him greatly on the Day of Pentecost and thereafter, including the writing of two epistles. We can learn two great lessons from this:

A. We should never be overconfident and think of ourselves as impregnable. (Galatians 6:1-4)

B. Even after we let the Lord down, He is still willing to use us if we will allow Him. Remember, he came unto Jonah the second time (Jonah 3:1). How many times has Christ come unto us to serve Him? Thank God for his grace to us and his patience with us.

"...But where sin abounded, grace did much more abound." (Romans 5:20b).

7. Caiaphas Sends Christ to Pontius Pilate: (John 18:28) .

"Then led they Jesus from Caiaphas unto the hall of judgment (the palace of the Roman Governor, there were many): and it was EARLY..."

This was probably about 4:00 A.M., Wednesday morning. Just prior to this, the chief priests had held a consultation with the elders, scribes, and Sanhedrin (the council) to put Him to death. They bound him and sent Him to Pilate. (Mark 15:1, Matthew 27:1,2).

Matthew 27:1 and Mark 15:1 both state it was morning and John says it was "early" when Christ was turned over to Pilate. In

XII. Resurrection

John 19:14, it was about the sixth hour. John uses Roman time, being six hours from Midnight; therefore, it was 6:00 A.M. on Wednesday. Matthew, Mark, and Luke use the Jewish time (from 6:00 P.M. to 6:00 P.M.) in stating the times when Pilate released Christ to be crucified. (We know it was Wednesday, as John 18:28 states,

“Then led they Jesus from Caiaphas unto the hall of judgment; and it was early; and they themselves went not into the judgment hall, lest they should be defiled; but that **THEY MIGHT EAT THE PASSOVER.**”

This would give Pilate about 2 hours from 4:00 A.M. to 6:00 A.M., Wednesday, in his dealings with Christ. Pilate made several trips from the hall of judgment, where Christ was, to the Jews waiting outside.

A. (OUT) John 18:29-31. When Christ was first brought to Pilate, he went out to the Jews to ascertain what charge they had against Him.

B. (IN) John 18:33-37. Pilate went back in and questioned Christ.

C. (OUT) John 18:38. Pilate went out again and declared he found no fault with Christ.

D. The Jews replied to Pilate that Christ had stirred up all the people in Judea, starting from Galilee. (Luke 23:5). Since Herod Antipas (Antipater), the ruler of Galilee, was in Jerusalem, Pilate sent Christ to him for judgment. Christ, being a Galilean, would be under his jurisdiction. This was Pilate's way out! Antipas found Him innocent, mocked Him, and arrayed Him with a gorgeous robe, and sent Him back to the judgment hall for Pilate. (Luke 23:7-15).

E. (IN) John 19:1-3. Pilate went back in to Christ. The soldiers placed a crown of thorns on His head and struck Him.

F. (OUT) John 19:4. Pilate went out to the Jews again, declaring "I find no fault in Him."

XII. Resurrection

G. (IN & OUT) John 19:5-8. Jesus was led out in view of the Jews, chief priests and officers. They cried, "Crucify him!"

H. (IN) John 19:9-12. Pilate took Jesus and went back into the hall of judgment (9) where he continued to question Christ.

I. (OUT) John 19:13. Pilate brings Christ out again to the judgment seat in the courtyard (Pavement). Pilate's wife sent a message to him and declared Christ innocent to her husband in Matthew 27:19,

".. Have nothing to do with that JUST man..."

8. Pilate Releases Christ for Crucifixion: About the sixth hour, Christ was released by Pilate for crucifixion (John 19:14). Keep in mind that John uses the Roman time, Midnight to Midnight, while Matthew, Mark and Luke use the Jewish time in dividing the day from 6:00 P.M. to 6:00 A.M. to 6:00 P.M. Therefore, Christ was released for crucifixion at about 6:00 A.M., Wednesday morning, just after being scourged by Pilate. (Matthew 27:26).

9. From 6:00 A.M., Wednesday Morning, to 9:00 A.M.: Within those three hours the following took place:

A. Christ taken to a common hall, striped of His clothing, which was replaced with a scarlet robe. (Matthew 27:27,28).

B. The crown of thorns placed on His head. (Matthew 27:29).

C. A reed placed in His right hand as they mocked Him as King. (Matthew 27:29).

D. They spit on Him and hit Him on the head with the reed, a measuring rod about 9 feet long. (Matthew 27:30).

E. Christ's robe removed and original attire replaced. (Matthew 27:31).

F. Christ is forced to carry His cross. (John 19:17). Our song containing the words "he fell beneath the cross" has no scriptural foundation.

XII. Resurrection

G. After a distance was covered heading toward Golgotha, Simon, a man of Cyrene, was compelled to carry Christ's cross the remainder of the way. (Matthew 27:32; Mark 15:21; Luke 23:26).

10. Christ is crucified the Third Hour: This being from 6:00 A.M., Jewish time; therefore, 9:00 A.M., on Wednesday morning. (Mark 15:25). The next three hours are filled with the events found in Mark 15:26-32 and Matthew 27:35-44.

11. The Sixth Hour to the Ninth Hour: This was from Noon to 3:00 P.M., Wednesday. There was darkness over the whole land while Christ was still upon the cross. Very shortly after 3:00 P.M., Christ submitted Himself unto death (Mark 15:34-37).

12. Let us recapitulate for a moment. On Wednesday, Pilate releases Christ for crucifixion at 6:00 A.M. Three hours later, he is placed on the cross at 9:00 A.M. After being on the cross three hours, darkness covers the earth for the next three hours He is there. Therefore, Christ was on the cross from 9:00 A.M. to 3:00 P.M., Wednesday. Shortly after 3:00 P.M. he was taken down. Three days later, between 3:00 P.M. and 6:00 P.M., Saturday, He had arisen!

This is only a brief picture of events that may help us visualize what took place some 24 hours before Christ's death on the cross.

Note: Excerpted from the book, *Three Important Questions*, by the author.

3d. Diagram B. A Time Chart of Events During the Week of Christ's Trial, Crucifixion, and Resurrection.

		6 PM						6 AM		Noon		6 PM		6 PM	
Tuesday	These Events Took Place Within this 12-Hour Period							9 AM	3 PM	6 PM		6 PM			
	Wednesday---During the Night—Wednesday							During the Day on Wednesday							
Last Supper	Prayer in the Garden	His Arrest	First Taken To Annas	Annas Delivers Him to Caiaphas	Peter Denies Christ 3 Times	Caiaphas Sends Christ To Pilate at Hall of Judgment	Pilate Releases Him to Be Crucified at about 6 AM	Events During 6 & 9 AM Wed. Morning	Crucified the Third Hour or 9 AM Wed. Morning	Darkness Over All the Land	Christ Submits Himself Unto Death		24 Hours Thursday	24 Hours Friday	24 Hours Saturday 3 PM Between 3PM & 6 PM Christ Arose!
1	2	3	4	5	6	7	8	9	10	11	12	72 Hours			
A TWENTY-FOUR HOUR PERIOD															

XIII. The Sabbath

1. *How Is The Sabbath Made For Man?*

Question: In Mark 2:27 the Bible says that, "*The sabbath was made for man, and not man for the sabbath.*" This verse seems contradictory and I don't understand it!

Answer: To begin, let us examine the first part of this verse, "*The sabbath was made for man.*" This is the Fourth Commandment, given first in Exodus 20:9-11. In Exodus 35:2 the penalty for breaking the Sabbath was death.

"Six days shall work be done, but on the seventh day there shall be to you an holy day, a sabbath of rest to the Lord: whosoever doeth work therein shall be put to death."

God made our physical bodies and minds and knows them better than we do. There are several reasons for this commandment. Here are a few:

1. Our bodies need one full day out of seven just to relax without the physical labor of work.

2. Our minds also need to be rested from the mental pressures and stress of our work.

3. God wants his people to have time, without the pressure of working for a living, to worship Him.

4. When you observe someone who works seven days a week, with no time off, you will usually see a change in their behavior at home. They will be short-tempered, irritable, with little patience—all because the body, soul, and spirit do not have the proper rest nor time for worship.

5. God knew that man, because of his greed, would literally work himself to death and forget the Lord Who created him. Therefore, the Fourth Commandment.

Now the last part of the verse in question (Mark 2:27). "*...and not man for the sabbath.*" In other words, the Law of the

XIII. The Sabbath

Sabbath prohibiting a person from working for his own profit or benefit on the Sabbath, did not prohibit a person from doing good for someone who needed help.

There is nothing wrong with eating on the Sabbath, so we are told in Verse 23 that,

"And it came to pass, that he (Christ) went through the corn fields on the sabbath day; and his disciples began, as they went, to pluck the ears of corn."

In Verse 24 the hypocritical Pharisees falsely accused Christ and the disciples of breaking the Sabbath. They did not even know their own law .

..."And the pharisees said unto him, Behold, why do they on the sabbath day that which is not lawful?"

In Verses 25 and 26 Christ rebuked them for their hatred, ignorance, and false accusations.

Christ's practice of doing good for someone on the Sabbath happened many times during His earthly ministry; which the Fourth Commandment never prohibited. In Matthew 12:9-14 we find that Christ went into the Synagogue on the Sabbath and healed a man with a withered hand. The Pharisees gathered and were plotting to kill Him for doing good on the Sabbath (V.14). Christ rebukes them in Verse 11,

"And he (Christ) said unto them, what man shall there be among you, that shall have one sheep, and if it fall into a pit on the sabbath day, will he not lay hold on it, and lift it out?"

In Verse 12, Christ makes it perfectly clear that the Fourth Commandment concerning the Sabbath did not prohibit a person from doing good and helping someone who needed help.

"How much then is a man better than a sheep? Wherefore, it is lawful to do well on the sabbath days."

In conclusion to your question about Mark 2:27:

1. *"The sabbath was made for man."* Rest your body, rest your mind, take time to relax and worship the Lord.

XIII. The Sabbath

2. "*And not man for the sabbath.*" It is not unlawful, nor is it breaking the sabbath to help or do good for someone else. It did prohibit working for yourself merely to keep adding to your wealth.

XIV. Salvation

1. *Can I Know, with Certainty, If I Am Going to Heaven?*

Question: Can anyone know, with certainty, they will go to Heaven when they die?

Answer: Yes! There is no greater peace than that of knowing, absolutely for sure, you have a home in Heaven when you leave this earth.

Let me explain. Since every human being has sinned (Romans 3:23); therefore, the "wages" of sin is death (i.e. eternal separation from God). God is just, and sin must be paid for—with no exceptions! There are only two possibilities: A person may pay for their own sin in Hell for all eternity or; exercise the only other choice, and accept by faith the payment Christ made for them on the cross. He gave His life to save ours.

In John 6:47 Christ said,

"Verily, Verily, I say unto you, He that believeth on me hath everlasting life."

"Therefore being justified (a legal term meaning "declared righteous") by FAITH, we have PEACE with God through our Lord Jesus Christ." (Romans 5:1).

"For we KNOW that if our earthly house of this tabernacle (our bodies) were dissolved (dead), we have a building of God, an house not made with hands, eternal in the HEAVENS." (2 Corinthians 5:1).

This is why God has given us His Word, as a record to be believed.

"And this is the record, that God hath given to us eternal life, and this life is in his son." (1 John 5:11).

"These things have I written unto you THAT BELIEVE on the name of the Son of God; that ye may KNOW that ye have eternal life..." (1 John 5:13).

God does not give a "guess so" or "hope so" salvation, we can KNOW we have eternal life because He promises it in His Word. You can believe a promise from God!

XIV. Salvation

2. Can a Saved Person Ever Be Lost?

Question: Could you give me the Scripture I need to show someone that we are once saved, always saved?

Answer: Christ tells us in John 6:37 there is no way God is going to take away our eternal life.

"All that the Father giveth me shall come to me; and him that cometh to me I will in no wise cast out."

Some will say, "All right. God won't cast me out; but I could get out of my own will and choice!" Go to John 6:39,

"And this is the Father's will which hath sent me, that of all which he hath given me I should LOSE NOTHING, but should raise it up again at the last day."

This verse tells us it is God's will that NO saved person would ever become lost. He says He will "lose nothing," and you are at least something! Actually, we are so important to God that He sent His only Son from Heaven to earth to die in payment for our sin!

1 Peter 1:4,5 lets us know that it is God who keeps us. God, himself, by His mighty power, is reserving a place in Heaven for us.

"To an inheritance incorruptible, and undefiled, and that fadeth not way, RESERVED in heaven for you. (4) Who are kept by the power of God through faith unto salvation ready to be revealed in the last time. (5)

If a saved person could go to Hell, the Holy Spirit would have to go to Hell, too. He indwells every believer from the moment he trusts Christ forevermore.

"In whom ye also trusted, after that ye heard the word of truth, the gospel of your salvation: in whom also after that ye believed, ye were SEALED with that holy spirit of promise." (13) Which is the EARNEST (down payment) of our inheritance until the redemption of the PURCHASED possession, unto the praise of his glory."(Ephesians 1:13,14).

XIV. Salvation

(Also see 1 Corinthians 6:19; and John 14:16,17).

John 10:28 "nails it down"! Christ gives eternal life, and they who receive this eternal life "shall *never* perish". "Never" in the original Greek is a double negative, meaning, "not at all, by no means, in no case, NEVER"!

"And I give unto them eternal life; and they shall NEVER perish, neither shall ANY MAN (not even yourself) pluck them out of my hand."

3. Does Hebrews 10:26-30 Mean a Christian Can Go to Hell?

Question: Does Hebrews 10:26-30 mean that a Christian can go to Hell? Please help.

Answer: The whole Book of Hebrews is a contrast between the Old Testament Law and the New Covenant made upon Calvary by our Savior, the Lord Jesus Christ. Chapter 10:1-18 continues the contrasts.

In Verse 19, Paul addresses those who are saved as "brethren." In Verse 23-25, instructions are given to the saved to follow, so they can grow in strength through the grace and knowledge of the Lord Jesus. (2 Peter 3:18). Paul, then, instructs the believers, in Verse 23, of the importance of remaining faithful. In Verse 24, he advises them of the importance of considering others and encouraging them to do the same. In Verse 25, he instructs them of the importance of "*not forsaking the assembling of yourselves together.*"

In Verse 26, the subject changes. Paul is now speaking concerning his Jewish brethren (i.e. in the flesh, not the Spirit), and identifies himself with them when he was without Christ.

Since Jesus Christ is "*the way, the truth, and the life: no man cometh unto the Father, but by me.*"... He then presented Himself unto Israel first. John 1:11 tells us that,

"He (Christ) came unto his own, (Israel) and his own (Israel) received him not."

XIV. Salvation

Paul, in Verse 26, is telling His Jewish brethren after the flesh, who are unsaved, that "If they reject Jesus Christ as their payment for sin; there is no *other* payment for sin. Therefore, there is no *other* sacrifice for sins." In Verses 27-31, Paul informs those who reject Christ what they have to look forward to when they die.

Now! In Verses 32-39, Paul reminds those Jews, who have received Christ as their Savior, to continue on in serving the Lord.

In Verse 39, the word "perdition" in the Greek means "To utterly destroy." The idea is not extinction; but ruin, loss; not of being; BUT of well-being". The word is used of both the saved and the lost. Also, the word "soul" is the same Greek word as "life" in many cases. For example: In Matthew 16:25, "life" is used twice. In Matthew 16:26, the word "soul" is used twice. All four are the same Greek word.

Verse 39 would literally read, "*But we (the saved) are not of them who draw back (from serving the Lord) unto perdition, (i.e. ruining our life); but of them that believe to the saving of the soul (life).*" Saving our life for what? To use to bring glory and honor to our Wonderful Savior, the Lord Jesus Christ, and to receive His present blessings and future rewards for being faithful.

4. Please Explain the Rich Man and The Kingdom of God

Matthew 19:24

Question: Can you please explain Matthew 19:24,

"...It is easier for a camel to go through the eye of a needle, than for a rich man to enter into the kingdom of God."

Answer:

First: A young man came to Christ, filled with self-righteousness. Instead of asking in humility and sincerity how he could have eternal life, he offered his self-righteousness when he

XIV. Salvation

said in Verse 16,

"What GOOD THING shall I do, that I may have eternal life."

Second: He did not believe Christ was the Savior, or he would not have asked what he could do to merit eternal life. This is evident when he addressed Christ as "Good Master"; i.e., a good teacher, but *not* the Son of God.

Third: Christ answered this young man according to his own proposal by saying in Verse 17,

"If thou wilt enter into life, keep the commandments."

This statement would condemn every person ever born. There were over 700 laws given to Israel and the 10 Commandments alone would condemn us as no one has ever kept them. (Galatians 2:16).

Fourth: The man, instead of being honest with himself, lied to Christ by saying,

"...All these things have I kept from my youth up: what lack I yet?" (Verse 20)

His self-deception was that he thought he was perfect.

Fifth: Christ exposed the man's self-righteousness by replying,

"...If thou wilt be perfect, go and sell that thou hast, and give to the poor." (Verse 21)

In Verse 22 we find

"...he went away sorrowful: for he had great possessions."

Sixth: In Verse 24 Christ illustrated the absolute impossibility of anyone ever going to Heaven on their good works; by using the example of a literal camel going through the eye of a literal needle. This is what the Rich Man thought he could do, as he was self-righteous. Christ was not setting forth works for Salvation; but, only, challenging the Rich Man on what he truly believed. Sadly, still clinging to his self-righteousness, he "*went away sorrowful.*" There is only one way of Salvation.

XIV. Salvation

"For by grace are ye saved through faith; and that not of yourselves: it is the gift of God: Not of works, lest any man should boast." (Ephesians 2:8,9)

5. *Why Does the Sin of Adam Make All Men Sinners?*

1 Timothy 2:14,15

Question: Can you shed some light on 1 Timothy 2:14,15?

"And Adam was not deceived, but the woman being deceived was in the transgression. (14) Notwithstanding she shall be saved in childbearing, if they continue in faith and charity and holiness with sobriety." (15)

Answer: When Eve sinned, death set in. She would die physically and spiritually (Genesis 2:17). Now, Eve had a physical body that was going to die. Adam did not, for he had not yet sinned. At this point in time, the human race could not have continued, for what nature would their children inherit? Would they have inherited Eve's fallen nature and ultimately died; or Adam's nature, and live on forever? Since the Bible says Adam was not deceived, he purposely sinned by partaking of the fruit *"of the tree of the knowledge of good and evil.* (Genesis 2:17a) Now they both possessed a sinful nature, which would be passed on to all humanity.

Notice in 1 Timothy 2:15 the phrase "in childbearing." "IN" is the Greek "dia" meaning "through." In other words, God will allow the human race to continue based on a condition, "through" Eve's bearing of children.

Looking back to Genesis 3:21 we find,

"Unto Adam also and to his wife did the LORD God make coats of skins, and clothed them."

They discarded their fig leaves of self-righteousness and accepted God's righteousness of the blood sacrifice, pictured in the animal skins. Had Adam and Eve refused God's gracious offer, the human race would not have continued; as their offspring would have filled the earth with nothing but God-

XIV. Salvation

denying heathen.

Returning to our text in 1 Timothy 2:15, Eve will be saved (alive) to continue the human race through bearing of children; since she and Adam had both accepted God's blood sacrifice. They were no longer innocent, they had fallen; but, through their acceptance of the sacrifice, they had the new nature of the Christian. They understood that their God-given righteousness was bought by the death of an innocent victim and would pass this information on to their offspring. This helps to explain the statement "*...if they continue in faith and charity (love) and holiness with sobriety,*" which they did. That is why Abel brought a blood sacrifice, which God accepted. He had been instructed by the first parents, Adam and Eve.

Not only was Mother Eve to be saved through childbearing, all mankind would be redeemed by the birth of the child, Jesus Christ; who grew up to be the only sacrifice God accepts today for our sin. He was the only perfect person who could sacrifice Himself for the sin of the world, because He had none himself.

That Eve also understood the blood sacrifice of animals was a temporary thing; and that a permanent sacrifice would one day be offered by Christ on Calvary is proven by her comment at the birth of her first son. "*...I have gotten a man from the Lord*" (Genesis 4:1), better translated, "I have gotten a man, even the Lord". No, her firstborn was not the promised Messiah, but in the proper time he would appear.

"In whom we have redemption through his (Christ's) blood, the forgiveness of sins, according to the riches of his grace;" (Ephesians 1:7).

6. *Is Baptism Required for Salvation?*

John 3:5

Question: In John 3:5 Christ told Nicodemus that "*...Except a man be born of water and of the Spirit, he cannot enter into the*

XIV. Salvation

kingdom of God." Is this referring to water baptism for salvation?

Answer: "Water," here, is referring to the Word of God. Peter, in his first epistle, clarifies "born again" in 1:23.

"Being born again, NOT of corruptible seed, (All the good we do, including water baptism, church membership, etc., will never produce the new birth) BUT of incorruptible, by the WORD OF GOD, which liveth and abideth for ever."

In John 15:3 we are told,

"...Ye are clean through the word which I have spoken to you."

We are cleansed by believing the word of God, not by baptism.

Again, in Ephesians 5:26, "water" is referring to the word of God.

"That he (Christ) might sanctify and cleanse it with the washing of water by the word."

Let us return to John, Chapter 3, where synonymous terms such as: "everlasting life," "not being condemned," "eternal life," and "being saved" are all used in reference to entering the kingdom of God.

"...whosoever BELIEVETH in him (Christ) should not perish, but have eternal life." (3:15)

"...whosoever BELIEVETH in him (Christ) should not perish but have everlasting life." (3:16)

"...but that the world through him (Christ) might be saved." (3:17)

"He that BELIEVETH on him (Christ) is not condemned..." (3:18)

"He that BELIEVETH on the Son hath everlasting life..." (3:36)

"...He that heareth my WORD, and BELIEVETH on Him (Christ) that sent me, hath everlasting life." (5:24)

XIV. Salvation

"...He that BELIEVETH on me hath everlasting life." (6:47)

Christ told the Samaritan woman at the well, in John 4:14,

"But whosoever drinketh of the water that I shall give him shall never thirst; but the water that I shall give him shall be in him a well of water springing up into everlasting life."

This spiritual water is the Word Christ gave her when He told her He was the Messiah (v.25,26), and He was the Christ, the Savior of the world (v.42). She believed Him.

Ephesians 1:7 makes it perfectly clear we are saved by the blood, not the water!

"In whom we have redemption through his (Christ's) blood, the forgiveness of sins, according to the riches of his grace."

7. *Once Saved, Always Saved; Or Eternally Secure?*

2 Peter 2:21

Question: I am a student at (certain college). My question is concerning "once saved always saved." My friend doesn't believe in eternal salvation. Her reason for not believing is 2 Peter 2:21. Can you please tell me what this verse is really saying?

Answer: 2 Peter 2:21 says,

"For it had been better for them not to have known (Greek "epiginosko" and means "to have a knowledge of, but not to partake in.") the way of righteousness, than, after they have known (epiginosko) it, to turn from the holy commandment delivered unto them."

2 Peter 2 deals with false teachers, beginning in Verse 1

"...there were false prophets among the people...there shall be false teachers among you..."...who... shall bring in damnable heresies, even denying the Lord that bought them..."

Verse 2 says

"...many shall follow their pernicious ways, by reason of whom the WAY OF TRUTH shall be evil spoken of."

These false teachers are deniers of the truth. They know

XIV. Salvation

(epiginosko) the truth, as 2 Peter 2:21 says; but, they do not BELIEVE the truth. They “turn from” the truth and preach a perverted, or accursed, message of reformation or good works for salvation (Galatians 1:6-9). They have not lost their salvation. They never possessed it, because they never accepted Christ!

In Verse 3, Peter warns that these false teachers

“...with feigned words will make a merchandise of you...”

The example of Balaam, who preached for gain, is given in Verse 15. They lead others astray with their false message. The blood of those that go into a Christ-less eternity will be on the hands of the false teachers, and God will judge them for it (Ezekiel 33:8). That is why 2 Peter 2:21 says

“For it had been better for them not to have known the way of righteousness, than, after they have known it, to turn from the holy commandment delivered unto them.”- 2 Peter 2:21

There are degrees of punishment in Hell (Revelation 20:13).

Peter warns the followers of these false teachers with examples of the judgment that falls on those who do not accept God’s truth. In Verse 4, everlasting fire for the angels that sinned (Matthew 25:41). In Verse 5, the “old world” perished in the flood because they did not believe the preaching of Noah. We see the destruction of Sodom and Gomorrah in Verses 6-8. If we die without accepting Christ’s payment on the cross for our sin, we will spend eternity in Hell (John 3:36).

Verses 10 through 20 describe the false teachers:

“Presumptuous...self-willed (10). “...speak evil of the things they understand not...(the Gospel) (12)” “...sporting themselves with their own deceivings while they feast with you....(13)” “Wells without water...(17)”

...or a message containing no truth about salvation by belief in Jesus Christ (John 4:14). They are like those in Matthew 7:22-23.

XIV. Salvation

“...Lord, Lord, have we not prophesied in thy name? and in thy name have cast out devils? and in thy name done many wonderful works? And then I will profess unto them, I never knew you: depart from me, ye that work iniquity.”
“...Believe on the Lord Jesus Christ, and thou shalt be saved...”
(Acts 16:31).

8. *What Is The Fruit of Salvation?*

John 15:4

Question: I do not believe you can lose your salvation, but John 15:4 is a verse I cannot explain.

Answer: John 15:4 says,

“Abide in me, and I in you. As the branch cannot bear fruit of itself, except it abide in the Vine; no more can ye, except ye abide in me.”

Chapter 15:1-16 is speaking of bearing fruit *after* you are a Christian. Seven times in these verses Christ mentions “fruit”. The “fruit” here is speaking primarily of winning others to Christ through our witnessing. To be motivated, we need to study God’s word (2 Timothy 2:15), so we can grow in our knowledge (2 Peter 3:18).

“...And be ready always to give an answer to every man that asketh you a reason of the hope that is in you with meekness and fear:” (1 Peter 3:15)

Get around other Christians who witness, as it will help increase your confidence. God wants us to bear “much fruit” as Christ states in Verses 5 and 8.

Personally, the greatest joy I have as a pastor is leading others to trust Jesus Christ as their personal Savior.

“These things have I spoken unto you, that my joy might remain in you, and that your joy might be full.” (John 15:11)

Some years ago, in a previous pastorate, we had a lady teaching one of our Sunday school classes. After her class she would leave and not stay for the morning church service; nor did

XIV. Salvation

she attend our evening service. The children began to question the faithfulness of their teacher. I talked with her about the bad example she was setting for the children. She was highly insulted, resigned the class, and left the church for good. In other words, she was removed out of her position because she was unfaithful.

This teacher fulfilled Verse 2,

“Every branch in me (i.e. the saved) that beareth not fruit he taketh away...”

Not “taken to hell,” she did not lose her salvation; but, lost her privilege to maintain her position of leadership. She was not “abiding in Christ” and yielding to the Holy Spirit (who seals us until the day of redemption (Ephesians 1:13,14)); but, allowing her old nature to control her thoughts and actions. She was not “bearing fruit.”

Sad to say, we have some Christians who desire a position of honor, but will not honor the Lord by being faithful. 1 Corinthians 4:2 sums it up,

“Moreover it is required in stewards that a man be found faithful.”

9. *What Happens If We Die with Un-Confessed Sin?*

Question: I think somewhere in the Bible it says that God cannot look upon sin. So...what if we die in a car accident or something, before we have a chance to ask forgiveness, what happens to that sin?

Answer: Concerning your thought that God cannot look upon sin. May I say that God looks upon sin endlessly when He looks upon His creation, for we are told in Ecclesiastes 7:20,

“For there is not a just man upon the earth, that doeth good, and sinneth not.”

Romans 3:23 further states,

“For all have sinned and come short of the glory of God.”

XIV. Salvation

The answer to this question lies in distinguishing between our salvation and our service to the Lord.

Our salvation was bought and paid for by the death and Resurrection of our Savior, Jesus Christ. It is offered as a free gift to anyone who will receive it by faith. Romans 6:23 says,

“For the wages of sin is death; but the gift of God is eternal life through Jesus Christ our Lord.”

You never have to ask Christ to forgive your sins to be saved; because He already did that 2,000 years ago upon the cross. Contrariwise, Christ is asking everyone to receive His forgiveness by believing He died for them, personally. (Acts 13:38,39). John 3:15 promises,

“That whosoever believeth in him (Jesus Christ) should not perish, but have eternal life.”

When we sin after we are saved, we are to confess that sin. Confession and forsaking the sin restores the fellowship with the Lord, and others, that we had before we sinned. 1 John is written to Christians. In 1 John 1:9 we are told,

“If we confess our sins, he is faithful and just to forgive us our sins, and to cleanse us from all unrighteousness.”

This is for fellowship, not salvation, as 1 John 1:7 states,

“But if we walk in the light, as he is in the light, we have fellowship one with another...”

Every Christian, when they get to Heaven, will stand accountable for how they lived their life after they were saved. They will receive rewards or suffer loss of rewards accordingly. 1 Corinthians 3:14,15 makes this perfectly clear.

“If any man’s work abide which he hath built thereupon, he shall receive a reward. (14) If any man’s work shall be burned, he shall suffer loss (i.e., of rewards): but he himself shall be saved...” (15)

Therefore, should a Christian die without confessing some sin or sins, they would suffer loss of rewards; but, not loss of their eternal life.

XIV. Salvation

Remember, Heaven is never a reward; but, a free gift. Rewards have to be earned after we are saved.

10. Does Galatians 5:4 Teach That You Can Lose Your Salvation?

Question: Does Galatians 5:4 teach that a Christian can lose his salvation?

Answer:

“Christ is become of no effect unto you, whosoever of you are justified by the law; ye are fallen grace.” (Galatians 5:4)

This is a favorite verse of those who believe you can lose your salvation. The verse is self-explanatory and teaches that any person who seeks to be justified by the law is not saved. Therefore, they are “fallen from grace,” literally meaning, they have rejected and have turned away from God’s grace. God’s grace provides salvation only as a free gift to be received by faith, and faith alone!

Galatians 5:4 teaches three distinct lessons:

1. No one in this verse has been saved, and then lost his salvation. How can one lose his salvation when he was never saved to begin with? The verse clearly begins with,

“Christ is become of no effect unto you...”

John 3:18 describes these unbelievers,

“He that believeth on him (Christ) is not condemned: but he that believeth not is condemned already, because he hath not believed in the name of the only begotten Son of God.”

Therefore, Christ’s death and Resurrection were of no effect unto them because of their unbelief. They were lost and condemned.

2. The reason they did not accept Christ as their Savior was because they were self-righteous. They were trying to justify themselves by keeping the law. Romans 10:4 lets us know,

XIV. Salvation

“For Christ is the end of the law for righteousness to every one that believeth.”

The Lord Jesus describes those in Luke 16:15 who are trying to merit eternal life with their own righteousness.

“And he (Christ) said unto them, Ye are they which JUSTIFY YOURSELVES before men; but God knoweth your hearts: for that which is highly esteemed among men is abomination in the sight of God.”

3. Those described in Galatians 5:4, because of their self-righteousness, could not admit and agree with God that they were sinners, lost on their way to Hell. They rejected God’s word in Romans 3:23,

“For all have sinned and come short of the glory of God.”

These self-righteous sinners were blinded to the truth in Romans 6:23,

“For the wages of sin is death; but the gift of God is eternal life through Jesus Christ, our Lord.”

Ephesians 2:8,9 states so clearly,

“For by grace are ye saved through faith; and that not of yourselves: it is the GIFT of God: Not of works, lest any man should boast.”

The response of those in our text to hearing that you are only saved by grace, was total rejection. It is described in Galatians 5:4 as *“falling from grace.”* In other words, they backed away from God’s grace; or, we might state it this way, they turned away from God’s grace and wanted nothing to do with it because of their self-righteousness. These could not lose their salvation, as they never had it to begin with.

Pentecostals are notorious for using Galatians 5:4 to support their claim of losing salvation. Catholicism has pawned off its imaginary Purgatory as a means of keeping you from losing your salvation, which actually denies the finished work of Christ on the cross for salvation. In John 19:30, Jesus’ last words were,

“...It is finished...”

XIV. Salvation

To the thief on the cross Christ said,

“Verily I say unto thee, To day shalt thou be with me in paradise.”

Not Purgatory!

11. How Can I Witness to My Jewish Friends?

Question: How can I witness to Jewish people and show them that Jesus Christ is their true Messiah?

Answer:

A. Zechariah 12:10 is a good verse to show that Jesus is God manifested in the flesh; therefore, He is their Messiah who was crucified. Here is how you use this chapter and Verse 10.

The King James Bible makes the distinction in the translation of the Hebrew names for God. Whenever you see “LORD” and “GOD” all capitalized, the Hebrew is always “Jehovah,” God’s personal name. (Isaiah 42:8). Whenever you see “God” written with a capital “G” and small “od,” it is from the Hebrew “elohim,” as in Genesis 1:1. “El” is the Hebrew for “God” and the “im” is a plural noun, meaning “three or more.”

We have two numbers in English language: singular, meaning one; plural, two or more. In the Hebrew, however, we have three numbers: singular, meaning one; dual, equaling two; plural, denoting three or more. Thus, “Elohim” is a plural noun — three or more.

“Elohim” indicates the Office of God and means “the putter forth of power.” Just as the Office of President of our country indicates his office of power; but, is not his personal name.

Now, back to Zechariah, Chapter 12. You show the Jewish person that it is Jehovah speaking, leading up to Verse 10. In Verses 1,4,7,8, the word “LORD” (all capitals) is the Hebrew “Jehovah.” In Verses 2,3, and 6, it is Jehovah still speaking.

XIV. Salvation

Then, have them read Verse 10.

"And I will pour upon the house of David, and upon the inhabitants of Jerusalem, the spirit of grace and of supplications: and they shall look upon me (Jehovah) whom they have pierced.." (Zechariah 12:10).

You may point out that the word "WHOM" is a compound of the first and last letters of the Hebrew alphabet, "aleph" and "taw." In Revelation 1:7,8, Jesus is the "Alpha and the Omega," illustrated by the first and last letters of the Greek alphabet. Jesus is truly God manifested in the flesh. (1 Timothy 3:16). John 1:41 states,

"He (Andrew) first findeth his own brother Simon, and saith unto him, We have found the Messias, which is, being interpreted, the Christ."

B. Deuteronomy 6:4. You can use this verse to show that Father, Son, and Holy Spirit are One. "Jehovah" is the singular noun and "Elohim" is three or more, being the plural noun.

"Hear, O Israel: The LORD (i.e. Jehovah, singular) our God (Elohim, plural) is one LORD: (Jehovah, singular)." (Deuteronomy 6:4).

Then, show the person Genesis 1:1,

"In the beginning God (Elohim, plural) created the heaven and the earth." (Genesis 1:1).

Note: Of all the Jewish people I have witnessed to, I have not found one that is aware the word "God" in Genesis One is the Hebrew word "Elohim." This is a total shock to them, as all I have encountered thought it was "Jehovah," the singular noun. In Genesis 1:2 we have the Holy Spirit involved in the remodeling of the earth; as also Jesus Christ is involved in creation, as stated in John 1:1-3 and Colossians 1:14-16.

XIV. Salvation

12. Does Titus 3:5 Teach Baptism For Salvation?

Question: Dear Dr. Younce, Would you please explain the last part of Titus 3:5; as I am getting conflicting information from some preachers.

Answer:

I. The Quotation:

“Not by works of righteousness which we have done, but according to his mercy he saved us, by the washing of regeneration, and renewing of the Holy Ghost;” (Titus 3:5)

II. The Explanation:

1. *“Not by works of righteousness which we have done...”*

No one is saved by doing works of any kind; whether, baptism, confirmation, church membership, financial contributions to charity, etc. These would all be considered *“works of righteousness,”* and we could think of many more. But, no matter how many we think of, Titus 3:5 says salvation is not given as the result of *“works of righteousness.”*

“For by grace are ye saved through faith; and that not of yourselves: it is the gift of God: Not of works, lest any man should boast.” Ephesians 2:8-9

2. *“But according to his mercy he saved us.”*

a. Grace is extending to a person what they do not deserve. Heaven is a perfect place, and since we are all sinners; none of us deserve to go there.

“But God commendeth his love toward us, in that, while we were yet sinners, Christ died for us.” (Romans 5:8)

b. Mercy is withholding what we do deserve. The *“wages of sin is death”*; or, separation from God for all eternity. This is Hell, the Second Death.

XIV. Salvation

*“For all have sinned, and come short of the glory of God;”
(Romans 3:23)*

c. Romans 6:23 shows the grace of God. If Jesus had not paid the price for the sin of mankind by His death on the cross, we would all be Hell-bound. Anyone can have eternal life simply by believing that Christ died for them.

“For the wages of sin is death; but the gift of God is eternal life through Jesus Christ our Lord.”

God has graciously provided a Savior whom we can accept; and, because of His mercy, escape the punishment in Hell we deserve.

3. *“Washing of regeneration.”* This is another way of describing what takes place when anyone accepts Jesus Christ as their Savior. We believe the Gospel (i.e. are "washed by the Word) and are "regenerated," or born again.

a. *“A new creation”* in 2 Corinthians 5:17 is another description of our salvation.

“Therefore if any man be in Christ, he is a new creature: old things are passed away; behold, all things are become new.” (2 Corinthians 5:17)

b. *“Born again”* in John 3:3 is another description of salvation

“Born” is the Greek verb “gennaō,” followed by “again,” the Greek adverb “anothen” which means; from above. In other words, “born from above.” The commentary on this is explained in 1 Peter 1:23.

“Being born again, not of corruptible seed, but of incorruptible, by the word of God, which liveth and abideth for ever. ”- 1 Peter 1:23

c. *“Washing:”* is the Greek “loutron,” and literally means to bathe or wash the body. We do not obtain salvation by taking a literal bath. The whole verse of Titus 3:5 is speaking of eternal salvation. As the first part of the verse

XIV. Salvation

clearly states, salvation is not by "*works of righteousness*"; therefore, this can not be referring to baptism.

"Washing" is used metaphorically of the Word of God; which, when one believes the Word of God, it becomes the instrument of spiritual cleansing; in other words, your salvation! (Romans 10:17).

"Now ye are clean through the word which I have spoken unto you." (John 15:3)

"That he might sanctify and cleanse it with the washing of water by the word," (Ephesians 5:26)

d. "Regeneration:" The Greek word for this is "palin-
genesisia." "Palin" means "again" and "genesis" is "birth." In other words, this is used in reference to our spiritual new birth when we receive Jesus Christ as our personal Savior. We are "born again"; or, "regenerated."

- (1). The new birth includes a relationship, as I am now a child of God.

"But as many as received him, to them gave he power to become the sons of God, even to them that believe on his name:" (John 1:12)

- (2). At salvation, your past is wiped clean and the Christian starts out brand new.

"Therefore if any man be in Christ, he is a new creature (creation): old things are passed away; behold, all things are become new." 2 Corinthians 5:17

- (3). I can never lose my salvation, as it is "everlasting."

"For God so loved the world, that he gave his only begotten Son, that whosoever believeth in him should not perish, but have everlasting life." John 3:16

"He that believeth on the Son hath everlasting life: and he that believeth not the Son shall not see life; but the wrath of God abideth on him." John 3:36

XIV. Salvation

e. *Renewing of the Holy Ghost*: The Greek for “renewing” is “anakainosis,” and is the continual working of the indwelling Holy Spirit in the Christian’s life. All Christians are indwelt by the Holy Spirit at the moment of salvation.

“In whom ye also trusted, after that ye heard the word of truth, the gospel of your salvation: in whom also after that ye believed, ye were sealed with that holy Spirit of promise,” (Ephesians 1:13)

13. *Does Doing Good to Your Fellow Man Get You to Heaven?*

Question: Does Matthew 25:31-46 endorse good works for eternal life in Heaven? In other words, "If you do good towards your fellow man, will the Lord just let you on in."

Answer: First, we quote the passage in question:

“When the Son of man shall come in his glory, and all the holy angels with him, then shall he sit upon the throne of his glory: (31) And before him shall be gathered all nations: and he shall separate them one from another, as a shepherd divideth his sheep from the goats: (32) And he shall set the sheep on his right hand, but the goats on the left. (33)

Then shall the King say unto them on his right hand, Come, ye blessed of my Father, inherit the kingdom prepared for you from the foundation of the world: (34) For I was an hungred, and ye gave me meat: I was thirsty, and ye gave me drink: I was a stranger, and ye took me in: (35) Naked, and ye clothed me: I was sick, and ye visited me: I was in prison, and ye came unto me. (36)

Then shall the righteous answer him, saying, Lord, when saw we thee an hungred, and fed thee? or thirsty, and gave thee drink? (37) When saw we thee a stranger, and took thee in? or naked, and clothed thee? (38)

Or when saw we thee sick, or in prison, and came unto thee? (39)

XIV. Salvation

And the King shall answer and say unto them, Verily I say unto you, Inasmuch as ye have done it unto one of the least of these my brethren, ye have done it unto me. (40)

Then shall he say also unto them on the left hand, Depart from me, ye cursed, into everlasting fire, prepared for the devil and his angels: (41) For I was an hungred, and ye gave me no meat: I was thirsty, and ye gave me no drink: (42) I was a stranger, and ye took me not in: naked, and ye clothed me not: sick, and in prison, and ye visited me not. (43)

Then shall they also answer him, saying, Lord, when saw we thee an hungred, or athirst, or a stranger, or naked, or sick, or in prison, and did not minister unto thee? (44)

Then shall he answer them, saying, Verily I say unto you, Inasmuch as ye did it not to one of the least of these, ye did it not to me. (45) And these shall go away into everlasting punishment: but the righteous into life eternal.” (46) Matthew 25:31-46

Even though it appears from this passage that doing good to your fellowman will result in eternal life; when we compare Scripture with Scripture, we find the answer.

1. The Difference Between the Rapture and the Revelation of Christ. The Rapture ends the Church Age, which began on Pentecost, and ignites the start of the 7-Year Tribulation Period of God’s judgments upon the earth. Two of the many Scriptures are found in 1 Corinthians 15:50-54 and 1 Thessalonians 4:13-18.

“Now this I say, brethren, that flesh and blood cannot inherit the kingdom of God; neither doth corruption inherit incorruption. (50)

Behold, I shew you a mystery; We shall not all sleep, but we shall all be changed, (51)

XIV. Salvation

In a moment, in the twinkling of an eye, at the last trump: for the trumpet shall sound, and the dead shall be raised incorruptible, and we shall be changed. (52)

For this corruptible must put on incorruption, and this mortal must put on immortality. (53)

So when this corruptible shall have put on incorruption, and this mortal shall have put on immortality, then shall be brought to pass the saying that is written, Death is swallowed up in victory.” (1 Corinthians 15:50-54)

“But I would not have you to be ignorant, brethren, concerning them which are asleep, that ye sorrow not, even as others which have no hope. (13)

For if we believe that Jesus died and rose again, even so them also which sleep in Jesus will God bring with him. (14)

For this we say unto you by the word of the Lord, that we which are alive and remain unto the coming of the Lord shall not prevent (precede) them which are asleep. (15)

For the Lord himself shall descend from heaven with a shout, with the voice of the archangel, and with the trump of God: and the dead in Christ shall rise first: (16)

Then we which are alive and remain shall be caught up together with them in the clouds, to meet the Lord in the air: and so shall we ever be with the Lord. (17) Wherefore comfort one another with these words.” (1 Thessalonians 4:13-18)

In Thessalonians, Christ does not come to the earth to set up the Kingdom or judge the nations. Every Christian alive is caught up to be with the Lord. The Christians who have died previously to this have already left their bodies to be with the Lord.

“We are confident, I say, and willing rather to be absent from the body, and to be present with the Lord.” (2 Corinthians 5:8)

They come back with the Lord and receive their glorified bodies, just as the Christians that are alive exchange their earthly

XIV. Salvation

bodies for their heavenly bodies. Notice the word “sleep” in Verses 13,14 is referring to their bodies, not their soul and spirit. The word “prevent” in Verse 15, is the Greek “phthano” and should have been translated “precede.” In other words, at the Rapture all Christians get their new, Heavenly bodies as we find in Philippians 3:20-21...

“For our conversation (citizenship) is in heaven; from whence also we look for the Saviour, the Lord Jesus Christ: (20) Who shall change our vile body, that it may be fashioned like unto his glorious body, according to the working whereby he is able even to subdue all things unto himself.” (21)

...and no human, sinful body (Romans 3:23) can ever enter the Third Heaven.

“Now this I say, brethren, that flesh and blood cannot inherit the kingdom of God; neither doth corruption inherit incorruption.” (1 Corinthians 15:50)

How wonderful! A new body and a new home where we will never experience death, sorrow, crying or pain, as is promised in Revelation 21:4.

“And God shall wipe away all tears from their eyes; and there shall be no more death, neither sorrow, nor crying, neither shall there be any more pain: for the former things are passed away.” Revelation 21:4

2. The Description of Events at the Revelation of Christ: The Revelation of Christ is when Christ comes back to the earth to establish His Kingdom for a 1,000 years. He judges the nations, defeats Satan and his army at the Battle of Armageddon, and chains Satan for a 1,000 years during the Kingdom rule and reign of Jesus Christ as King of Kings and Lord of Lords. (Revelation 20:1-3).

It should be noticed that in the gospels: Matthew, Mark, Luke, and John, that every reference to Christ’s coming is NOT

XIV. Salvation

the Rapture; but, rather, the Revelation of Christ at the conclusion of the 7-Year Tribulation. The Old Testament prophets knew nothing of the Rapture, as it was a mystery until revealed unto the Apostle Paul. (Ephesians 3:1-10). The Rapture and the Revelation are entirely two different events, separated by seven years. Notice carefully that, at the Rapture, the Christians are taken up and the lost are left. At the Revelation of Christ when He comes and judges the nations the opposite takes place. The lost are taken and thrown into the Lake of Fire.

“Then shall he say also unto them on the left hand, Depart from me, ye cursed, into everlasting fire, prepared for the devil and his angels.”(Matthew 25:41)

The saved are left to enter the earthly Kingdom of Christ.

“Then shall the King say unto them on his right hand, Come, ye blessed of my Father, inherit the kingdom prepared for you from the foundation of the world:” (Matthew 25:34)

At the Rapture Christ does not come to the earth; BUT, at the Revelation, he does.

3. The Doctrinal Truth of Matthew 25:31-46: Does Matthew 25:31-46 endorse good works for eternal life in Heaven? First, it should be noted that no one has ever been saved by their good works. If you visit the link on our website again, you will find that is the total point.

“For by grace are ye saved through faith; and that not of yourselves: it is the gift of God: (8) Not of works, lest any man should boast.” (Ephesians 2:8-9)

If anyone could go to Heaven on their own good works, then Christ would not have had to pay for the sins of all humanity on the cross. In the verses quoted below, you have the same kind of people from the beginning of Creation as you have today; the saved and the lost. The sinner who believes God’s Word.

XIV. Salvation

***“For all have sinned, and come short of the glory of God;”
(Romans 3:23)***

“For what saith the scripture? Abraham believed God, and it was counted unto him for righteousness. (3) Now to him that worketh is the reward not reckoned of grace, but of debt. (4) But to him that worketh not, but believeth on him that justifieth the ungodly, his faith is counted for righteousness.” (Romans 4:3-5)

Then you have the sinner who, through his pride and self-righteousness, rejects Christ as his Savior.

“And the Pharisees also, who were covetous, heard all these things: and they derided him. (14) And he said unto them, Ye are they which justify yourselves before men; but God knoweth your hearts: for that which is highly esteemed among men is abomination in the sight of God.” (Luke 16:14-15)

“And he spake this parable unto certain which trusted in themselves that they were righteous, and despised others:” (Luke 18:9)

“The Pharisee stood and prayed thus with himself, God, I thank thee, that I am not as other men are, extortioners, unjust, adulterers, or even as this publican.” (Luke 18:11)

The key to these verses in Matthew 25 is the word “BRETHREN.” The brethren are those believers in Christ who are spiritually related to Christ by their faith. In John we are told:

“But as many as received him, to them gave he power to become the sons of God, even to them that believe on his name:” (John 1:12)

By our belief in Christ as our Savior, we are spiritually related to Him as a son; or, sometimes referred to as “brethren.” This is clearly brought out by Hebrews 2:9,11:

XIV. Salvation

“But we see Jesus, who was made a little lower than the angels for the suffering of death, crowned with glory and honour; that he by the grace of God should taste death for every man.” (9)

“For both he that sanctifieth and they who are sanctified are all of one: for which cause he is not ashamed to call them brethren,” (11)

In Matthew 12:46-50 we have the contrast between the physical brethren and the spiritual brethren:

“While he yet talked to the people, behold, his mother and his brethren stood without, desiring to speak with him. (46) Then one said unto him, Behold, thy mother and thy brethren stand without, desiring to speak with thee. (47) But he answered and said unto him that told him, Who is my mother? and who are my brethren? (48)

And he stretched forth his hand toward his disciples, and said, Behold my mother and my brethren! (49) For whosoever shall do the will of my Father which is in heaven, the same is my brother, and sister, and mother.” (50)

Notice in Verse 50. What is doing the will of the Father? It cannot be good works, as works do not make you a biological relative to another who does good works, anymore than standing inside a garage makes you a car! This is speaking of a spiritual relationship of yourself to another, as a man, woman, mother or brother, who also believes in Christ as their Savior. So, let us see what the will of the Father is, according to the Word of God in John 6:39,40,

“And this is the Father's will which hath sent me, that of all which he hath given me I should lose nothing, but should raise it up again at the last day. (39) And this is the will of him that sent me, that every one which seeth the Son, and believeth on him, may have everlasting life: and I will raise him up at the last day.”(40).

One can easily see that the will of God, first to the last, is for a person to believe in Jesus Christ as their Savior.

XIV. Salvation

“He that BELIEVETH on the Son hath everlasting life: and he that believeth not the Son shall not see life; but the wrath of God abideth on him.” John 3:36

In Matthew 7, we find some using God and His Word as a counterfeit of Christianity, projecting to and deceiving the people by their hypocrisy and self-righteousness. Their end was eternal damnation for trusting good works for self-glory.

“Not every one that saith unto me, Lord, Lord, shall enter into the kingdom of heaven; but he that doeth the will of my Father which is in heaven. (21)

Many will say to me in that day, Lord, Lord, have we not prophesied in thy name? and in thy name have cast out devils? and in thy name done many wonderful works? (22)

And then will I profess unto them, I never knew you: depart from me, ye that work iniquity.” (Matthew 7:21-23)

With this preamble, let us go back to Matthew 25, Verses 31-40.

“When the Son of man shall come in his glory, and all the holy angels with him, then shall he sit upon the throne of his glory: (31) And before him shall be gathered all nations: and he shall separate them one from another, as a shepherd divideth his sheep from the goats: (32) And he shall set the sheep on his right hand, but the goats on the left. (33)

Then shall the King say unto them on his right hand, Come, ye blessed of my Father, inherit the kingdom prepared for you from the foundation of the world: (34) For I was an hungred, and ye gave me meat: I was thirsty, and ye gave me drink: I was a stranger, and ye took me in: (35) Naked, and ye clothed me: I was sick, and ye visited me: I was in prison, and ye came unto me. (36)

Then shall the righteous answer him, saying, Lord, when saw we thee an hungred, and fed thee? or thirsty, and gave thee drink? (37) When saw we thee a stranger, and took thee in? or naked, and clothed thee? (38)

Or when saw we thee sick, or in prison, and came unto thee? (39)

XIV. Salvation

And the King shall answer and say unto them, Verily I say unto you, Inasmuch as ye have done it unto one of the least of these my brethren, ye have done it unto me. (40)

These were the saved, helping their Christian brethren that had a need. They were not trusting their good works; but, doing so because of their love for Jesus Christ, who loved them and paid for their sins on Calvary. Christ would never have greeted them with these words from Verse 34, if they had been trusting their good works for salvation.

“Then shall the King say unto them on his right hand, Come, ye blessed of my Father, inherit the kingdom prepared for you from the foundation of the world:”

Now the lost, as described in Verses 41-46...

Then shall he say also unto them on the left hand, Depart from me, ye cursed, into everlasting fire, prepared for the devil and his angels: (41) For I was an hungred, and ye gave me no meat: I was thirsty, and ye gave me no drink: (42) I was a stranger, and ye took me not in: naked, and ye clothed me not: sick, and in prison, and ye visited me not. (43)

Then shall they also answer him, saying, Lord, when saw we thee an hungred, or athirst, or a stranger, or naked, or sick, or in prison, and did not minister unto thee? (44)

Then shall he answer them, saying, Verily I say unto you, Inasmuch as ye did it not to one of the least of these, ye did it not to me. (45) And these shall go away into everlasting punishment: but the righteous into life eternal.” (46)

These were the lost, who had no concern for Christ or anyone else who was a Christian. When a person is full of self, there is no room for Christ to be involved. One thing that Christ CANNOT do, and that is send a believer to Hell. These were the unsaved.

“Verily, verily, I say unto you, He that heareth my word, and believeth on him that sent me, hath everlasting life, and shall not come into condemnation; but is passed from death unto life”. (John 5:24)

XIV. Salvation

One must remember that Christ sees inside of a person's mind and thoughts, although we cannot. Christ is...

*"...a discerner of the thoughts and intents of the heart. (12)
Neither is there any creature that is not manifest in his sight: but all things are naked and opened unto the eyes of him (Christ) with whom we have to do." Hebrews 4:12-13*

Ezekiel 11:5 proclaims the same omniscience of God concerning Israel...

"...for I know the things that come into your mind, every one of them."

Christ knew their wicked hearts, which were evidenced by their outward disregard for the Christians who were the children of God, bought with the sacrifice Christ paid on the cross. Christ, the Righteous Judge, renders their just verdict:

"...and these shall go away into everlasting punishment." (46a)

Christ also knew the hearts of the saved; which evidenced their faith, and which Christ described in Verses 34-36, 40.

"Then shall the King say unto them on his right hand, Come, ye blessed of my Father, inherit the kingdom prepared for you from the foundation of the world: (34) For I was an hungred, and ye gave me meat: I was thirsty, and ye gave me drink: I was a stranger, and ye took me in: (35) Naked, and ye clothed me: I was sick, and ye visited me: I was in prison, and ye came unto me. (36)

And the King shall answer and say unto them, Verily I say unto you, Inasmuch as ye have done it unto one of the least of these my brethren, ye have done it unto me." (40)

Always remember, salvation is a free gift.

"For by grace are ye saved through faith; and that not of yourselves: it is the gift of God: (8) Not of works, lest any man should boast." Ephesians 2:8-9

"Knowing that a man is not justified by the works of the law, but by the faith of Jesus Christ, even we have believed in Jesus Christ, that we might be justified by the faith of Christ, and not by

XIV. Salvation

the works of the law: for by the works of the law shall no flesh be justified.” Galatians 2:16

“But to him that worketh not, but believeth on him that justifieth the ungodly, his faith is counted for righteousness.” Romans 4:5

XV. Satan & The Demons

1. *Was the Serpent In Eden a Literal Snake?*

Question: Was the Serpent in Genesis 3 a literal snake? (Reference: Gen. 3:1,14) I cannot understand how a serpent could talk to Eve and then end up being a snake. What is the answer?

Answer: Satan is described as a serpent in Genesis 3, not a literal serpent or snake as some have projected, but, rather as a description of his character.

If God had meant a literal snake, He would have directed the Holy Spirit to inspire Moses to write down Genesis 3:1 this way. *"Now the serpent was more subtil than any (other) beast of the field."*

The Scripture is merely saying that Satan is more subtil, or crafty, than any "beast of the field," in the same way we would say, "Sly as a fox," "Strong as an ox," or, "Slippery as an eel." The Scripture is describing Satan's character.

Satan is called by many names. Notice in Revelation 12:9 where he is called "dragon," "serpent," "Devil," and "Satan."

"And the great dragon was cast out, that old serpent, called the Devil, and Satan, which deceiveth the whole world..."

In Revelation 12:10 he is called the "*accuser*." In Ephesians 2:2 he is referred to as "*the prince of the power of the air*." In Ezekiel 28:14, before Satan's fall, he was referred to as "*the anointed cherub*." These are all descriptions of his character, some before his fall and some after.

In Ezekiel 28 God describes the literal king of Tyre who becomes a picture of the Devil, who was the spirit who deceived the king, therefore causing the king to be the personification of the Devil. Consider Ezekiel 28:13, where we are told,

"Thou (Satan) hast been in Eden the garden of God..."

XV. *Satan & The Demons*

Let us return to Genesis 3:14 where we are told concerning Satan, that had been in Eden,

"...upon thy belly shalt thou go, and dust shalt thou eat all the days of thy life."

This is usually the verse that brings about the idea of a snake in some people's eyes. If I am not mistaken, snakes eat rodents, and not dust!

When someone experiences defeat we used to use the phrase, "They bit the dust!" Every time a lost person trusts Christ as Savior, Satan has "bitten the dust," because he has lost claim to them for eternal Hell that was created for him (Matthew 25:41).

Satan would like to see every Christian living bring a disgrace to Christ; BUT, when we put on the *"whole armor of God,"* (Ephesians. 6:11,13) we are *"able to stand against the wiles (cunning devices, craft, or deceit) of the Devil."* Therefore, Satan has again "bitten the dust" in defeat.

His ultimate end will be in biting the dust in defeat when he is cast into the Lake of Fire, forever! (Revelation 20:10)

2. *Why Did God Create the Devil?*

Question: Pastor Younce, can you tell me why God created the Devil?

Answer: No, I cannot! Because God did not create the Devil; neither did God create man as a sinner. In Ezekiel 28 we have the word of God concerning the literal king of Tyre; but it becomes a picture of the Devil, who deceived the king of Tyre. Thus, the king of Tyre personifies the Devil. In Verse 12, Lucifer was *"created full of wisdom and perfect in beauty."* In Verse 14, he was the *"anointed cherub."* Verse 15 says,

"Thou wast perfect in thy ways from the day that thou wast created, till iniquity was found in thee".

XV. Satan & The Demons

Isaiah 14 tells us why he sinned.

"How art thou fallen from heaven, O Lucifer, son of the morning!... (12a) For thou hast said in thine heart, I will ascend into heaven, I will exalt my throne above the stars of God: I will sit also upon the mount of the congregation, in the sides of the north: (13) I will ascend above the heights of the clouds; I will be like the most high." (Isaiah 14:12-14).

Lucifer wanted to take over the throne of God.

Lucifer persuaded one-third of all the angels to follow him (Revelation 12:4). From this time on he is called "Satan" (meaning "Adversary"), "Devil" ("Accuser"), "Serpent," "Dragon" (descriptive of his character) and etc. (Revelation 12:9)

God's reaction to his rebellion *"Thou shalt be brought down to Hell."* (Isaiah 14:15). Matthew 25:41 tells us, *"Depart from me, ye cursed, into everlasting fire, prepared for the devil and his angels"* His final end is given in Revelation 20:10,

"And the devil that deceived them was cast into the lake of fire and brimstone...and shall be tormented day and night for ever and ever."

God's plea is

"Believe on the Lord Jesus Christ and thou shalt be saved"

...saved from spending eternity in Hell with Satan.

3. ***Why Do the Devils Tremble When They Believe?***

Question: In James 2:19 the Bible says *"Thou believest that there is one God' thou doest well: the devils also believe and tremble."* How can we be saved by believing while they are lost by believing?

Answer: The word "devils" should be "demons," as there is only one devil but myriads of demons. Angels are created beings. Colossians 1:16:

For by him were all things created, that are in heaven, and that are in earth, visible and invisible..."

XV. Satan & The Demons

When Satan attempted to dethrone God (Isaiah 14:13-17), he tried to get all the heavenly host to follow him, but only one-third did (Revelation 12:4). This sealed their eternal fate in Hell (Matthew 25:41). The most wicked are in Torment today (2 Peter 2:5), awaiting the eternal lake of fire. The one-third are known as demons today. Yes, they know and believe that everything in the Bible is true; but they have believed too late (Matthew 8:29).

In Luke 16, a rich man was an unbeliever, but in Hell he believed, however it was too late. Notice his words in Verse 28,

"For I have five brethren; that he may testify unto them, lest they also come into this place of torment."

There are no unbelievers in Hell, but they believe too late, just like the demons.

"Behold NOW is the day of Salvation."

"Believe in the Lord Jesus Christ (NOW) and thou shalt be saved."

4. Can Satan Deceive Us With Visions and Dreams?

Question: I am a Christian and my friend tells me that God gives him dreams and visions. Could this be Satan trying to deceive him?

Answer: Yes, Satan is a master at counterfeiting the Lord. One of his masterpieces of counterfeiting God was in the dream or vision he gave to Eliphaz to instruct Job concerning his trials. In the dream Satan posed as God; but, the deception was that the advice and false accusations did not apply to Job.

Follow with me Eliphaz's dream (See Job 4:12,13, and 16.),

"Now a thing was secretly brought to me...In thoughts from the visions of the night, when deep sleep falleth on men. Then a spirit passed before my face; the hair of my flesh stood up: It stood still...an image was before mine eyes, and I heard a voice saying."

The following is the advice to Job from the dream.

XV. Satan & The Demons

"I would seek unto God, and unto God would I commit my cause:" (5:8).

"He taketh the wise in their own craftiness: and the counsel of the forward is carried headlong." (5:13)

Job answers:

"To him (Job) that is afflicted pity should be shewed from his friend...My brethren have dealt deceitfully..." (6:14,15).

Eliphaz to Job:

"For thy mouth uttereth thine iniquity, and thou choosest the tongue of the crafty. Thine own mouth condemneth thee, and not I: yea, thine own lips testify against thee:" (Job 15:5,6)

Job answers Eliphaz:

"But he (God) knoweth the way that I take: when he hath tried me, I shall come forth as gold. My foot hath held his steps, his way have I kept, and not declined." (23:10,11).

Now God rebukes Eliphaz for applying Satan's dream to Job in Chapter 42, Verses 7,8,

"...the Lord said unto Eliphaz the Temanite, My wrath is kindled against thee,... for ye have not spoken of me the thing that is right, as my servant Job hath. (7) "Therefore...go to my servant Job, and offer up for yourselves a burnt offering: and my servant Job shall pray for you: for him will I accept: lest I deal with you after your folly, in that ye have not spoken of me the thing which is right, like my servant Job."(8)

You should read the whole account for yourself. Satan deceived Eliphaz into thinking he (Satan) was God, applying his (Satan's) words to Job, which scenario God had nothing to do with. God harshly rebuked Eliphaz for being deceived by Satan and perpetrating his lie to Job.

Visions and dreams are deceptive; but, God's word is always true. In John 14:6,

"Jesus saith unto him, I am the way, the truth, and the life: no man cometh unto the father, but by me (Christ)."

XVI. Tongues, Faith Healing, Signs

1. *What Are the Greater Works Spoken of in John 14:12?*

Question: In John 14:12 the Bible says that, "*greater works than these shall he do.*" What are these greater works?

Answer: Let us look at the verse in its entirety:

"Verily, verily, I say unto you, he that believeth on me, the works that I do shall he do also; and greater works than these shall he do; because I go unto my Father."

This refers to the miracles and blessings the disciples experienced in the Book of Acts. Notice Hebrews 2:4:

"God also bearing them witness, both with signs and wonders, and with divers (various) miracles, and gifts of the Holy Ghost, according to his own will."

Our Lord performed many miracles in the sight of thousands—many are recorded, but many are not. These were to convince Israel that He, Christ, was their Messiah. In John 1:11 it is recorded that,

"He came unto his own (Israel), and his own received him not."

Israel crucified their own Messiah in spite of the miracles He and the apostles (Matthew 10) performed to authenticate His Deity. In John 20:30,31 we find that:

And many other signs (miracles) truly did Jesus in the presence of his disciples, which are not written in this book. But these are written, that ye might believe that Jesus (humanity) is the Christ (Deity, the Messiah), the Son of God; and that believing ye might have life through his name.,

The last miracle of Paul is recorded in Acts 28. Sometime around 57 A.D., after Pentecost, Paul declared in 2 Corinthians 12:7-10 that he could not heal himself, as he had previously done in Acts 28:1-6, when bitten by a viper. The miracle signs had ceased even before the completion of God's word, the Book of Revelation, written in approximately 96 A.D.

XVI. Tongues, Faith Healing & Signs

The "greater works," spoken of in John 14:12, are the works Christ does through us; which are greater in the sense that we are mere human vessels, while He was God Incarnate on earth. We cannot raise the dead, physically, today; BUT, we can present God's Word. God's Word, specifically the Gospel, received by faith will resurrect a sinner who is dead in trespasses and sins (Ephesians 2:1), into a child of God (John 1:12). They are now spiritually alive and possessing everlasting life (John 3:16,17). These are the "greater works." Winning the lost!

2. What Was Paul's Thorn?

2 Corinthians 12:7-9

Question: What exactly was the "thorn in Paul's flesh? Was it a physical ailment he dealt with all through his life?

Answer: Here is the record.

"...there was given to me a thorn in the flesh, the messenger of Satan to buffet me, lest I be exalted above measure. For this thing I besought the Lord thrice, that it might depart from me. And he said unto me, 'My grace is sufficient for thee; for my strength is made perfect in weakness. Most gladly therefore will I rather glory in my infirmities, that the power of Christ may rest upon me.'" (2 Corinthians 12:7-9)

We are not told the exact nature of Paul's illness. Some think that Paul's 'thorn in the flesh' was poor eyesight; as he relates that the Galatians would have "...*plucked out your own eyes and have given them to me.*" in Galatians 4:15. In Galatians 6:11 the verse reads "*Ye see {with how large letters} I have written unto you with mine own hand.*" Ordinarily, he dictated his letters.

We know it was a physical illness, for it was "a thorn in the *flesh.*" This is a good example to show that the sign gifts (including healing) had ceased. The above passage was written about 58-60 A.D., and we find that the Apostle Paul could not heal himself. Previously he had temporarily blinded a sorcerer

XVI. Tongues, Faith Healing, Signs

(Acts 13:11), a cripple walk (Acts 14:8-10), cast out a demon (Acts 16:18), performed another healing (Acts 28:8), and special miracles (Acts 19:11,12). There were many who were *not* healed from about 60 A.D. on to the present. Here are a few: Epaphroditus (Philippians 2:25-30), Timothy (1 Timothy 1:2,5:23), Trophimus (2 Timothy 4:20). In most cases, God now seems to let events take their natural course.

God has allowed mankind to learn much about science and medicine. He has given doctors for our benefit. God expects us to use the blessings of medical knowledge He has given us. In James 5:14-16 we find the elders anointed with oil (medicine) and prayed. That is what God wants us to do today. Use the medicine and knowledge available, and bathe it with prayer.

God can and does step in, at His will; but, it is not through the phony "faith-healer" procedures that are so prevalent today. When God heals, He heals completely and without charge! It is always right to appeal to the "Great Physician." He is always in!

"And the prayer of faith shall save the sick, and THE LORD (if it is His will) shall raise him up..." (James 5:15a)

3. Is There Physical Healing in the Atonement?

Isaiah 53:4

Question: In Isaiah 53:4 it says,

"Surely he (Christ) hath borne our griefs, and carried our sorrows: yet we did esteem him stricken, smitten of God, and afflicted."

I was told that the word "griefs" in Hebrew means sicknesses, and "sorrows" means disease. Also, I was told that the healing is in the atonement; so, after I am a Christian, I won't have any more sickness. Is this right?

Answer: So-called "faith healers" thrive on this verse, deceiving many people. It is true "griefs" means sickness, and

XVI. Tongues, Faith Healing & Signs

“sorrows” means diseases. This prophecy only concerns the Lord Jesus Christ and the physical healings He would do prior to the cross, as evidence He was the Jewish Messiah. All the healings Christ performed fulfilled this prophecy as evidenced by Matthew 8:16,17.

“...they brought unto him (Christ) many that were possessed with devils: and he cast out the spirits with his word and healed ALL that were sick: (16) That it might be FULFILLED which was spoken by Esaias the prophet, saying, Himself took our infirmities, and bear our sicknesses.”

Now, in Isaiah 53:5 we have the healing that is in the atonement; His death on the cross and His Resurrection. This is spiritual healing, or salvation; not physical healing.

“But he (Christ) was wounded for our transgressions, he was bruised for our iniquities: the chastisement of our peace was upon him; and with his stripes we are healed.”

Peter makes this perfectly clear in 1 Peter 2:24,

“Who his own self BARE OUR OWN SINS in his (Christ’s) own body on the tree, that we, being dead to sins, should live unto righteousness: by whose stripes ye were healed.”

The healing in the atonement is salvation; not physical healing.

I have personally challenged many so-called “faith healers” to go to the hospitals with me and heal all those little children that are sick. None have accepted, so far. Remember, they go to the doctor also when they get sick or need an operation!

4. Is Speaking In Tongues Proof of Salvation?

Question: A friend has told me that I should learn to speak in tongues; and then I would know if I am really saved. Is this true?

Answer: There is only one way to know if we are really saved. Just as the Philippian Jailer asked Paul and Silas in Acts 16:30, 31,

XVI. Tongues, Faith Healing, Signs

"...Sirs, what must I do to be saved? And they said, Believe on the Lord Jesus Christ and thou shalt be saved..."

There is only one thing we must do to have eternal life; that is, believe that Jesus Christ died to pay for our sins. Ephesians 1:13 tell us,

"In whom (Christ) ye also trusted, after that ye heard the word of truth, the gospel of your salvation: in whom also after that ye believed, ye were sealed with the holy Spirit of promise."

We are sealed by the indwelling of the Holy Spirit upon the moment of belief; and we do not need to seek for any further proof of our salvation, such as the "speaking in tongues." We need no greater assurance than is found in God's Word. John 3:16 promises that if we believe in Jesus Christ we have, right now! eternal life.

The Holy Spirit will never give anyone the gift of tongues now. They are not for today. 1 Corinthians 13:8 tells us

"...Whether there be tongues, they shall cease:..."

"Cease" is the Greek verb "pauo." It means "to cease or stop completely." It is used in the perfect tense. This means that when tongues do cease, the action of ceasing will never be interrupted, but will continue forever. In plain words, once tongues cease they will never be reactivated at anytime in the future. It is also in the middle voice, denoting emphasis. The most emphatic statement in this verse is "TONGUES SHALL CEASE".

1 Corinthians 13:10 tells us when tongues will cease.

"But when that which is perfect is come, then that which is in part shall be done away. "

The key word in this verse is "perfect." Some say it is referring to Christ's coming. "Perfect" is the Greek word "teleion" and means "full grown and mature, complete." It refers to the end of a process or development. The Second Coming of Christ is not a process, but an instantaneous event. "Perfect" is never used in the New Testament for the Second Coming of

XVI. Tongues, Faith Healing & Signs

Christ, the Millennium, or Eternal State.

The word "perfect" ("teleion") is an adjective, here used as a noun. It is in the NEUTER gender. If "perfect" were referring to a person, it would be masculine or feminine. Since it is in the neuter gender, it is not referring to a person, but an object—the completed Word of God.

After the word of God was completed, no more need existed for prophecies (instant inspiration of preachers "on the spot"), tongues ("glossa," known languages), or knowledge (a special knowledge given by God to ascertain whether, or not, what that the individual was saying was truly of God).

As to the matter of being "really saved." You can not be a little bit saved, anymore than you can be a little bit dead! You can either be saved or lost. Which are you?

"...Believe on the Lord Jesus Christ, and thou shalt be saved..."

XVII. Young Earth, A False Doctrine

1. The Fraudulent Young Earth Theory or Philosophy

Where Did The Young Earth Philosophy Originate?

The following excerpt is taken from Microsoft Encarta Encyclopedia 2002.

“In fact, with one prominent exception, virtually all of the leading creationists of the 1920s endorsed either the Day-Age or Gap Interpretation of Genesis. THE EXCEPTION was Seventh-Day Adventist teacher and amateur geologist, George McCready Price, WHO FOLLOWED Adventist Prophet, Ellen G. White, in limiting the history of life on earth to about 6,000 years. Price attributed most fossil-bearing rock formations to the geological disruptions of the Biblical flood.”

Note: It appears that both Price and Ellen G. White held that BOTH the earth and human life have existed for only about 6,000 years.

The same encyclopedia further states under the heading “RECENT TRENDS” the following:

“Flood geology gained wider acceptance after the publication of “The Genesis Flood” (1961) jointly authored by conservative Biblical scholar, John C. Whitcomb, Jr., and hydraulic engineer, Henry M. Morris. This immensely influential book promoted Price’s views as fundamentalist orthodoxy, and prompted the formation in 1963 of the Creation Research Society. The society is dedicated to the promotion of what has come to be known as young-earth Creationism (by contrast with old-earth Creationism associated with the Day-Age and Gap theories). The most distinctive feature of young-earth creationism is its reliance on catastrophism, the doctrine that large-scale changes the earth’s crust are to be explained by violent, unrepeatable geologic events, such as the Genesis flood.”

Now, let us analyze the preceding information.

XVII. Young Earth, A False Doctrine

2. Two Views of Creation

1. In the 1920s, most Creationists held one of two views:

One was the Gap Principle which endorsed the Biblical teaching that the Original Creation in Genesis 1:1 was beautiful. There, Lucifer, the anointed cherub (Ezekiel 28:14) and the angels resided. Lucifer and one-third of the angels rebelled and brought God's judgment upon the Original Creation, which was later found in a desolate and waste condition, as recorded in Genesis 1:2.

The unspecified length of time between God's judgment on the earth rendering it uninhabitable; until His remodeling it for man's habitation, beginning in Genesis 1:2b, is known as the Gap Principle, NOT A THEORY. This time period, along with the Original Creation, is what the "young-earth" advocates attempt to do away with. The length of time the angels resided on the Original Creation until Satan's rebellion is not given. In reality, this unspecified time period has no relativity to the young earth advocates, because they deny God's Word concerning the foregoing.

2. The second view held in the 20s and to this present time is called the "Day-Age" theory.

In other words, a day in Genesis, Chapter One, is not a 24-hour period of time; but, rather, a geological age. The question then asked is, "How long is a geological age?" The answer is, any number of years they dream up! A 1,000 years, 300,000, or 500,000, or a million, maybe 500 million, or any number of years will do, just as long as we put the word "scientific" beside it. We are then led to believe it is true. What a joke! In 1 Timothy 6:20, young Timothy was warned,

"O Timothy, keep that which is committed to thy trust, avoiding profane and vain babblings, and oppositions of science (knowledge) falsely so called."

Included in this category are some who say that God created

XVII. Young Earth, A False Doctrine

the first “blob.” From this, things evolved to their present state. This is what is called “Theistic Evolution.” Later, we will show the fallacies and impossibility of the Day-Age theory and give proof of a literal, 24-hour day.

3. From the Encyclopedia’s article, it appears the Adventist Prophet, Ellen G. White, may have been one of the first, if not the first in advocating the young earth theory. Then an Adventist teacher, George McCready Price, followed her theory. Then Biblical scholar, John C. Whitcomb, Jr., and hydraulic engineer, Henry M. Morris co-authored “The Genesis Flood” (1961). Their book promoted Price’s views of a “young earth.” Now, everyone seems to have jumped on the young earth bandwagon. After 1900+ years, we have finally found the truth, or so they propose!

It amazes me that when someone wants to pawn off their theory about something, it is either scientific or advocated by a Biblical SCHOLAR. As long as one addresses an issue and concludes with their opinion, then it must be true because it is either scientific, or it is from a so-called Biblical scholar.

I remember reading H.G. Wells’ *The Outline of History*. This man didn’t believe the Bible at all, but was a believer in evolution. In his book he was trying to align my thinking with his. As I went back through the book, I circled such phrases as “We are led to believe,” “We can now assume,” “It is most possible,” and others. By the use of such statements, he was trying to magnetize my thinking to his. This man actually had no proof to substantiate his beliefs.

This, in some respects, reminds me of the young earth philosophy. When their geology disagrees with the clear teaching of the word of God; it is meaningless, as to how many times they use the word “scientific” and /or “Biblical scholar.” Rev. Whitcomb, Mr. Morris, I do not know for sure; but, I do wonder, did your young earth idea come from the cult religionist and Adventist Ellen G. White and/ or George Price?



XVII. Young Earth, A False Doctrine

Some might ask, “Why should we take the time to search out the meaning of Genesis 1:1-3 with regard to the Original Creation, the Judgment, and the Remodeling of earth? It can’t be that important.” Here is one scholar’s Answer:

“Here are some reasons we should study and seek to understand this doctrine. *“All scripture is given by inspiration of God, and is profitable for doctrine, for reproof, for correction, for instruction in righteousness”* (2 Timothy 3:16).

That, in a sense, says it all. If God talked about it, it is important. If He wrote it, it has profit for us.”

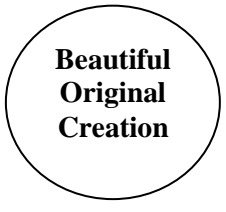
3. Creation Diagram One : The Gap Principle Illustrated

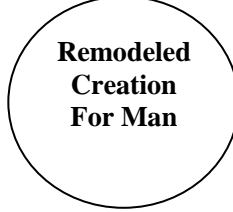
		
<ol style="list-style-type: none"> 1. Earth created beautiful. 2. Domain of Lucifer & the Angels 3. Genesis 1:1 4. Isaiah 45:18 5. No time of Creation given. 	<ol style="list-style-type: none"> 1. Lucifer’s sin brought God’s judgment upon the earth. Isaiah 14,Ezekiel 28 2. Angels now disembodied spirits. 3. Earth now desolate and uninhabited. 4. Gen. 1:2, Isa. 45:18 5. <i>“The earth became without form and void...”</i> 	<ol style="list-style-type: none"> 1. Genesis 1:3-19. The four days of remodeling. 2. Genesis 1:20 to 25. Living creatures created on 5th day. 3. Genesis 1:28,29 Adam & Eve created on the 6th day.

XVII. Young Earth, A False Doctrine

The above diagram will be helpful to identify the progression from God's Original Creation of the earth, His judgment upon it, and His remodeling it for man's habitation.

4. *Genesis One, "Created" and "Made."*

These two words, translated from two different Hebrew words, are very important in understanding God's Original Creation; and His Remodeling of the Earth after its judgment. Let's examine each word and its significance in respect to the earth.

"Created."

The Hebrew word for "created" is 'bara.' This word first appears in Genesis, Chapter One. It always means the instant, miraculous creation of something which had no previous existence in any form whatsoever. The three places "bara" (created) appears in Genesis One are as follows:

(1). Genesis 1:1: *"In the beginning God CREATED (bara) the heaven and the earth."* They have never existed before this.

(2). Genesis 1:21: *"And God CREATED (bara) great whales, and every living creature that moveth, which the waters brought forth abundantly, after their kind, and every winged fowl after his kind: and God saw that it was good."* (They never existed before this.)

(3). Genesis 1:27: *"So God CREATED (bara) man in his own image, in the image of God created he him; male and female created he them."* (Man never existed before this.)

"Made."

The Hebrew word for made is "asah." This word means "to release from restraint, to make, to allow, or to assemble. The late Dr. Harry Rimmer, D.D., SC.D., had this to say concerning the Hebrew for "made."

XVII. Young Earth, A False Doctrine

“This is the word that would be used to describe the production of a piece of furniture by a carpenter, or the assembling of a motor by a skilled mechanic. In the case of the carpenter it would not be proper to say he had “created” a table: he merely manufactured the article out of materials which were already in existence. It would be equally wrong to say that the mechanic had created a motor which he had (only) assembled.”

Note: When we see in English the words “made” and “created,” they have basically the same meaning to the average person, which has caused much confusion; but, not so in the Hebrew. In the Hebrew, they have distinctively different meanings, the knowledge of which is imperative to understanding Genesis, Chapter One. This, the young earth advocates absolutely refuse to accept!

Therefore, the first four days of Genesis are not an Original Creation, but a remodeling process of already existing materials that had been held in restraint or bondage. That is why the Holy Spirit used the precise Hebrew words brought into our English language as “made” and “let,” i.e. or “allow.”

C. God’s Original Creation, (Genesis 1:1) was created beautiful and to be inhabited. Isaiah 45:18 makes this perfectly clear:

“For thus saith the LORD that created the heavens: God himself that formed the earth and made it; he hath established it, he created (Hebrew, “bara”) it not in vain, he formed it to be inhabited: I am the LORD; and there is none else.”

Now, let us compare Isaiah 45:18 with Genesis 1:1,2 which states:

***“In the beginning God created the heaven and the earth.” (1)
And the earth was without form, and void; and darkness was upon the face of the deep. And the Spirit of God moved upon the face of the deep.” (v.2)***

Notice, in Isaiah, the word “vain.” It is the Hebrew word “tohuw” and means “without form, wilderness, to lie waste, desolation and etc.” Concerning this word in reference to the

XVII. Young Earth, A False Doctrine

Original Creation, it is stated that “...*he* (God) *created* (Hebrew “bara”) *it* (the earth) *not in vain*, (i.e., a waste of desolation). It was formed and established perfect and beautiful, to be inhabited. Isaiah continued by saying, “...*he* (God) *formed it to be inhabited*.” This describes the condition of the earth in Genesis 1:1 as God originally created it; and his purpose for creating it, “*to be inhabited*.”

Notice in Genesis 1:2 where, at some later time, it was declared that “...*the earth was* (had become) *without form and void*.” The word “void” in Verse 2 is the same word as “vain” in Isaiah 45:18 i.e., “a complete ruin, a desolation and uninhabitable.”

Let us now find out who the Original Creation was created for, who inhabited it, and what brought about it’s judgment.

5. Lucifer, The Anointed Cherub & The Angels of God

The question has been asked many times, “Where did the Angels come from? The Holy Spirit had directed His pen in Colossians 1:16 to give us the answer.

“For by him were all things created, that are in heaven, and that are in earth, visible and invisible, whether they be thrones, or dominions, or principalities, or powers: all things were created by him, and for him.”

Therefore, Satan, all the Heavenly Host, and everything that exists are a direct result of God’s creation.

Isaiah 14 and Ezekiel 28, both speak of Satan; thus, giving us a good deal of information concerning Satan’s rebellion, which necessitated God’s judgment. In Ezekiel 28:13, it states that Satan was created. In Verse 15 concerning Satan, we are told that:

“Thou wast perfect in thy ways from the day that thou wast created, till iniquity was found in thee.”

XVII. Young Earth, A False Doctrine

In Verse 14 it states that, *“Thou (Satan) art the anointed cherub.”*

The Original Creation of the earth, in Genesis 1:1, was to be occupied by Lucifer and the angels. This creation is what God is speaking about in Job 38:2-7:

“Who is this that darkeneth counsel by words without knowledge? (2) Gird up now thy loins like a man; for I will demand of thee, and answer thou me. (3) Where wast thou when I laid the foundations of the earth? Declare if thou hast understanding. (4) Who hath laid the measures thereof, if thou knowest? Or who hath stretched the line upon it? (5) Whereupon are the foundations thereof fastened? Or who laid the corner stone thereof; (6) When the morning stars sang together, and all the sons of God shouted for joy? (7)”

Verses 4-6 describe the Original Creation; and, we find in Verse 7, the “stars” and the “Sons of God” are already in existence. Now, let us examine what these are:

“The Morning Stars”

At the creation of the earth, Job 38:7 says that, *“the morning stars sang together.”* Some of the commentaries assume that these “stars” are referring to angels. Should one study the Doctrine of Angelology, you will not find anywhere where angels are said to sing. It is recorded that they shout and talk; but, contrary to the opinion of many, they do not sing. Then, what are these “stars?” If they are literal stars; then, how do they sing? In his book, “Has God Spoken,” by Arnold O. Schnabel, on Page 12, has this documentation that stars emit sound.

“The Hebrew word for “sing” is “ranan” and pertains to the emittance of a loud creak, shrill, or stredulous sound. Job declared that stars emit loud, shrill, credulous sounds that are audible. In an attempt to determine whether stars emit sound, Grote Raber tried to detect radio waves from the sun. His results were negative. Raber tried again with “inconclusive” results.

The same year, United States Army scientists were testing secret radar equipment developed for detecting German aircraft. This

XVII. Young Earth, A False Doctrine

equipment used a wave length of 400 to 500 centimeters. Suddenly in February of 1942, the radar sets received extremely high noise so loud they could not be operated. At first it was thought to be a form of German "jamming." The direction of the sound was soon traced; however, and found to be caused by the activities of a sun spot. — This discovery gave birth to the radio telescope as a research tool after the war. It is now known that radio waves that enter our atmosphere vary in length from 0.8 centimeters to 17 meters. The natural ear is not designed to hear the shrill of the stars."

God simply records their sounds as "singing." In Psalm 98:8, we are told that the "floods clap their hands." Isaiah 55:12 speaks of the "mountains and hills singing;" also, the "trees of the field shall clap their hands." The flood waters crashing against objects is like "the clapping of hands." Anyone who has ever hunted in the mountains has heard the wind howling as it blows against the side of the crevices, emitting a whistling sound described by God as the "mountains and hills singing." If you have ever been in the woods when a strong wind is blowing, you have surely heard the tree limbs smacking together. God describes this action as the "trees clapping their hands," just as God describes the stars that emit sound as "singing."

It is important to keep in mind that the stars were already created before God created the earth. This is why you will not find in Genesis One any record of stars being created when He remodeled the earth out of a chaotic condition to make it fit for human life. They had already been created prior to God's creation of the earth in Genesis 1:1.

"The Sons of God."

"The sons of God shouted for joy." It must be recognized that the "sons of God" here in Job 38 and Job, Chapters 1 and 2, are the angels that God had created. These are sons of God by creation, not regeneration.

The "*sons of God*" in the New Testament are specified as such because of their relationship to the Lord. Notice John 1:12

XVII. Young Earth, A False Doctrine

which substantiates this:

“But as many as received him (Christ), to them gave he power to become the sons of God, even to them that believe on his name.”

Not only did God create the stars previously; but, also, the angels were in existence prior to His creating the earth in Genesis 1:1. When God created the earth, the angels *“shouted for joy.”* Why would they shout for joy? Because God had created the earth for them. This beautiful creation of earth was to be their primary place of habitation. They were appointed an overseer, a leader who was to guide them in love, faithfulness and service to their Creator, God Almighty. This was to be the responsibility of the "Anointed Cherub," Lucifer.

6. Satan and The First Garden of Eden

May I call your attention back to Isaiah 45:18 where God stated He *“...created it (earth) not in vain (a waste or desolation), he formed it to be inhabited.”* To see how beautifully God had created the earth for the habitation of His angels, we find Ezekiel describes the earth as *“...Eden the garden of God.”* In Ezekiel 28:13,14, its description is beautiful.

“Thou (Satan) hast been in Eden the garden of God; every precious stone was thy covering, the sardius, topaz, and the diamond, the beryl, the onyx, and the jasper, the sapphire, the emerald, and the carbuncle, and gold: the workmanship of thy tabrets and thy pipes was prepared in thee in the day that thou wast created.” (13) “Thou art the anointed cherub that covereth; and I have set thee so: thou wast upon the holy mountain of God; thou has walked up and down in the midst of the stones of fire.” (14)

How marvelous and magnificent was God's earth that he created for the habitation of His angels as we know them today. As we have already seen from Job 38:4-7, the stars and the angels had already been created and in existence; and, then, God created the earth for their habitation.

XVII. Young Earth, A False Doctrine

7. *The Five “I Wills” of Satan.*

In Isaiah 14:13,14 we have the five “I Wills” of Satan. Here is the record:

“For thou (Satan) hast said in thine heart, I WILL ascend into heaven, I WILL exalt my throne above the stars of God: I WILL sit also upon the mount of the congregation, in the sides of the north: I WILL ascend above the heights of the clouds; I WILL be like the most high.”

Notice carefully that stars and clouds have already been created, and in existence, when the angels occupied the earth. This earth was Lucifer’s throne, as God’s Anointed Cherub.

“I will exalt my throne above the stars of God” (V.13),

...was Satan’s ambition. The first “I will” was to...

“...ascend into heaven.”

The fifth “I will” was to...

“...be like the most High.”

At the very least, he would only settle for being co-equal with Jehovah.

The Judgment.

God always judges sin wherever it is found. Speaking concerning Satan,

"Thou wast perfect in thy ways from the day thou wast created, till iniquity was found in thee." (Ezekiel 28:15)

Briefly, we list only two of the many judgments God rendered against Satan, and the third of the angels that followed him. We are concerned with the following two, as they shed much light concerning the misunderstood time element between the original creation of the earth inhabited by the angels, and God's remodeling of the earth for man's habitation.

Disembodiment. The angels and Satan became disembodied spirit beings. What kind of materialistic bodies they possessed

XVII. Young Earth, A False Doctrine

while on earth, we are not told. In Ezekiel 28:14, we are told,

"...thou (Satan) wast upon the holy mountain of God; and thou hast walked up and down in the midst of the stones of fire."

Notice Verse 17,

"Thine heart was lifted up because of thy beauty, thou hast corrupted thy wisdom by reason of thy brightness..."

Walk, beauty and brightness are attributes of the body they had. They are now disembodied and known to us as demons or spirit beings. Remember, the angels with God can be seen in bodies when permitted by the Lord. (Read Matthew 28:1-8.)

The Earth Was Cleansed.

The earth, which had been contaminated by Satan's and the angels' rebellion, was cleansed by God's judgment to such a degree that it was found without form, lying in waste like a wilderness. Genesis 1:2,

"And the earth became (because of God's judgment) without form and void (a waste) and darkness was upon the face of the deep."

With this background, let us proceed.

In Ezekiel 28:15 we are told that,

"Thou (Satan as Lucifer) wast perfect in thy ways from the day that thou was created, till iniquity was found in thee."

This verse is very interesting as it reveals some things we had not known, and conceals some things we will never know this side of eternity.

What We Know:

- A. We do know he was created. Satan had a beginning.
- B. We do know he was created with a free will.
- C. We do know that, from his creation until he inhabited the earth, his ways were perfect.

XVII. Young Earth, A False Doctrine

D. Iniquity was not found in him until sometime after he was appointed the “anointed cherub.” (Ezekiel 28:15) and given the earth as his throne (Isaiah 14:13).

What We Do Not Know:

A. We do not know how long it was from the time Satan and the angels were created until they were given the earth (Genesis 1:1); which was designated as Satan’s throne.

B. We do not know how long Satan occupied the earth before iniquity (sin) was found in him.

C. We do not know the length of time from God’s creating the beautiful earth until He judged Satan’s sin; therefore, rendering the earth a waste, desolation and uninhabitable; being in total darkness and covered with water, as found in Genesis 1:2.

D. We do not know how long the earth remained in this desolation, until God decided to remodel it for human habitation in Genesis 1:2b-31.

The young earth advocates do not want you to believe God’s Word concerning this, as they claim this only supports the time needed for evolution and supports the evolutionists. This false philosophy of these young earth people fades into oblivion should they realize the following.

When God pronounced judgment and rendered this earth a total waste, **THERE WAS NOTHING ALIVE ON THE EARTH TO EVOLVE FROM!**

One of the young earth proponents is Mr. Ken Ham, Executive Director of “Answers in Genesis (AIG).” Mr. Ham, in his statement of faith, states that “The ‘gap’ theory has no basis in Scripture.” Also stated is, “The final guide to the interpretation of Scripture is Scripture itself.” AIG states the gap (i.e., a period of time) is a theory and not a fact based upon Scripture.

XVII. Young Earth, A False Doctrine

In other words, he does not believe Isaiah 45:18, which states God did not create (bara) the earth in the desolate and waste condition, and covered with water as found in Genesis 1:2,

“And the earth was (became) without form and void...”

It was not created that way. In Genesis 1:1, when God originally created the earth, Isaiah says it was...

“...created to be inhabited.”

Ezekiel 28:12-19 and Isaiah 14:12-15 clearly teach that Lucifer's (Satan's) throne and residence were here on the earth. His rebellion (sin) brought about God's judgment on his residence, which was found...

“without form and void and darkness was upon the face of the deep.”

...as Genesis 1:2 records. AIG does not believe these Scriptures; therefore, the Gap Period of time is modified in their minds to a theory; instead of factual truth, supported by Genesis 1:1,2; Ezekiel 28:12-19; Isaiah 14:12-15.

Mr. Ham's advice to all who will study the Bible is that we must allow Scripture to interpret Scripture; or, in other words, we must assess all Scripture pertaining to a certain subject, or doctrine, to arrive at the correct teaching of the Word of God. Mr. Ham's advice is excellent! The sad commentary to this is, that what he advises others to do; he, himself, will not adhere to his own advice.

Many of you are well familiar with the name, Dr. Warren W. Wiersbe. He has been a noted Bible expositor for many years. He has pastored three churches; including the great Calvary Baptist Church in Covington, KY, and the famous Moody Bible Church in Chicago, IL. He has served as General Director and Bible Teacher of “Back to the Bible,” headquartered in Lincoln, Nebraska. He is Writer-in-Residence” at Cornerstone College in Grand Rapids, MI, and Distinguished Professor of Preaching in Grand Rapids Baptist Seminary. He is the respected author of

XVII. Young Earth, A False Doctrine

many, many books, too numerous to mention. Here are his comments concerning the gap of time principle between Genesis 1:1 and Verse 2:

“It is held by many students that the original creation of the universe (Gen. 1:1) was followed by the fall of Satan (Isa.14:12ff) and the ruin of God’s handiwork. It is possible that there is a “gap” between 1:1 and 1:2; so that we may read Vs. 2, “And the earth became without form and void...” Isa. 45:18 states that God did not create the earth “in vain” (Hebrew “without form”) so that the chaotic condition of the earth must have been caused by judgment. Ezek. 28:11-19 suggests that Lucifer, the highest of God’s created beings in this original creation, wanted to take the place of God; and this brought about the judgment. We find Satan already at work in Genesis 3, so that his fall had to take place earlier. This means that the creative activities of Genesis 1 are really a restoration of the ruined universe.” (Whole Bible Study Course, Originated by D.B. Eastep, Outline and Comments by Warren W. Wiersbe, Pastor, Calvary Baptist Church, Covington, KY.)

8. *Holding to A Young Earth Philosophy of 6,000 Years, Causes Your Witnessing to Be Ineffective.*

Personally, I have witnessed to scores of people who have endorsed evolution. Their reasoning is that man has been on the earth millions of years; or, i.e., since the earth was originally created; therefore, they associate man’s existence as equal to the age of the earth. This is the problem. When they understand that the Original Creation of the earth could very well be millions of years old; BUT, that man has only been on the *reconstructed earth* for approximately 6,000 years; the “gap” or, better terminology, the lapse of time between the Original Creation and God remodeling the earth for human life, disassembles the theory of evolution. It was the angels that occupied the Original Creation, not man.

XVII. Young Earth, A False Doctrine

9. After The Rehabilitation of The Earth

After the earth was rehabilitated, man was created and placed in the Garden of Eden. If one would trace the genealogies from Adam to Noah, you will find it is 1056 years. The flood came when Noah was 600 years old. (Genesis 7:6,11). Therefore the time from the creation of man to the flood is 1656 years.

Should one desire a continued, concentrated study of the years from the flood to the birth of Christ, they would arrive at approximately 2,345 years. Thus, from Adam to Christ is close to the figure of 4,000 years. Add another 2,000 plus from Christ to the present, and you have man on the earth for only 6,000 years. Therefore, the Gap Principle, as documented in Scripture makes evolution an absolute impossibility. The Gap Principle made it possible for me to lead many people to Jesus Christ as their Savior, who had been influenced by the evolutionary philosophy.

10. What Does The Bible Say?

The young earth advocates want you to disregard the Hebrew and other Scriptures that expose their philosophy. They surely do not want you to be aware of the marking in the Masoretic Text at the end of Genesis 1:1, indicating the proper translation of the disjunctive “BUT” instead of the conjunctive (or connecting) “AND.” In the manuscript the reading would be:

***“In the beginning God created the heaven and the earth. BUT
(Hebrew “waw”) the earth was (became) without form, and
void;”***

“Was.” The Hebrew for “was” is “hayah.” It is important to distinguish whether the verb “was” is in the manuscript, or if it has been inserted by the translators. It is wonderful that the King James translators made this distinction. When “was” appears not italicized, that indicates it is in the Masoretic Text. When you see “was” italicized, it indicates it does not appear in the manuscripts, but is understood. This is very important to notice

XVII. Young Earth, A False Doctrine

when reading your King James Translation, which makes this distinction. Notice in Genesis 1:2 where the verb “was” appears twice: first, as part of the Masoretic Text; and, second, as italicized, and not in the original text.

“And (BUT) the earth was without form, and void; and darkness was (italicized) upon the face of the deep...”

On the following pages you will find Creation Diagram Two, and comments, showing the word order of Genesis 1:1,2. You read the chart from right to left and the English Translation is found below the Hebrew.

Please refer to Diagram Two on the next two pages.



The Anvil Of God's Word

Last eve I passed beside a blacksmith's door
And heard the anvil ring the vesper chime;
When looking in, I saw upon the floor,
Old hammers worn with beating years of time.

"How many anvils have you had," said I,
"To wear and batter these hammers so?"
"Just one," said he; then with a twinkling eye,
"The anvil wears the hammers out, you know."

And so, I thought, the anvil of God's Word,
For ages, skeptics blows have beat upon;
Yet, though the noise of falling blows was heard,
The anvil is unharmed - the hammers gone.

John Clifford

XVII. *Young Earth, A False Doctrine*

10b. *Creation Diagram Two: Hebrew and English Compared*

<p>1 וְאֶת הָאָרֶץ:</p> <p>Earth the and conj. Heavens the <u>and</u>*</p>	<p>1 בְּרֵאשִׁית בְּרָא אֱלֹהִים אֶת הַשָּׁמַיִם וְאֶת הָאָרֶץ:</p> <p>beginning In created God</p>	<p>2 וְהָאָרֶץ הָיְתָה תְּהוֹ וּבְהוֹ וְחֹשֶׁךְ עַל-פְּנֵי תְהוֹם</p> <p>earth the <u>But</u> form the became void <u>and</u> (without) darkness <u>and</u> face upon deep</p>	<p>2 וְרוּחַ אֱלֹהִים מְרַחֵף עַל-פְּנֵי הַמַּיִם:</p> <p>God Spirit <u>and</u> moved face upon Waters the</p>
--	---	--	--

1. Uses of The Hebrew Verb “hayah” meaning “to be, i.e. existence.”

A. When the verb is *not* in the original, it is a simple connecting verb. No change has occurred.

B. When the verb is *in* the original, and placed at first part of a sentence, it means a present situation of existence is changing.

XVII. *Young Earth, A False Doctrine*

C. When the verb is in the original, and follows the subject of a sentence, it indicates a change in existence has already occurred.

2. In the Massoretic Text, there is one small mark, known as the “Rebhia” or “Silluq.” It is a “disjunctive” accent” and is to notify the reader he should pause before the next verse. It indicates a break in the text. Such a mark appears at the end of Genesis 1:1. This shows That the initial “waw” or “ו” at the beginning of Verse 2 should be translated “but,” rather than “and.” It is a disjunction, not a conjunction. From “Without Form and Void” by Arthur C. Custance, Ph.D.

Note the Silluq which always appears under the last word of a verse, as in Genesis 1:1, :פְּאָרֶץ, “the earth.” It is the third mark from the right. This is the greatest stop in a verse and is regularly followed by the sign (:) called Soph Pasuq, equivalent to our period.” Edward W. Goodrick, “*Do It Yourself Hebrew and Greek,*” Zondervan. Mr. Goodrick was Professor of Greek and Bible at Multnomah School of the Bible for many years.

3. The and shown in Genesis 1:1. We find this “and” is in the original; but it was not translated, as in the English Language we express the “definite direct object” by word placement in a sentence

4. In Genesis 1:2, “earth” is the subject of the sentence, and “became” is the verb. As the chart clearly shows, the verb “hayah” or “became” is in the original, follows the subject, and should be translated “became” or “had become.”

XVII. Young Earth, A False Doctrine

Let us recapitulate to Genesis 1:2 and examine two important words. They are the words “AND” and “WAS.”

*“In the beginning God created (bara) the heaven and the earth.
(2). AND the earth WAS without form, and void; and darkness
was (italicized, not in the original text) upon the face of the
deep...”*

1. “And.” The Hebrew is “waw,” (pronounced “vav”). The question is, “Should “waw” be translated “and,” which would be a conjunction connecting Verses 1 and 2? Or, should “was” be translated as “but,” therefore being a disjunctive instead of the conjunctive “and?”

There are two principle reasons why “waw” should be translated “but” showing a disjunctive relationship between Genesis 1:1 and 2.

a. First, “but” would be the correct translation; because, in the Masoretic Text, there is a small mark that is technically known as a “Rebhia.” This mark indicates that there is a break in the thought. In this case, the break is between Verse 1 and Verse 2. In other words, stop and think or consider before reading Verse 2; because there is a change that has taken place.

At the end of Verse 1, this mark appears in the Masoretic Text, showing a change of thought in Verse 2 from Verse 1. Therefore, the Hebrew “waw” should be translated “BUT” as a disjunctive, showing a change of thought will appear in Verse 2.

b. Second, Scripture in Isaiah 45:18 agrees perfectly with the Hebrew “waw” translated as “but” being a disjunctive. “But” indicates that something happened that the earth became without form and void; because, in Genesis 1:1 it was not originally created that way. It was created in Verse 1 to be inhabited (Isaiah 45:18). When you take the Word of God, everything fits perfectly.

The young earth advocates want you to disregard the

XVII. Young Earth, A False Doctrine

Hebrew and other Scriptures that expose their philosophy. They surely do not want you to be aware of the marking in the Masoretic Text at the end of Genesis 1:1; indicating the proper translation of the disjunctive “BUT,” instead of the conjunctive (or connecting) “AND.” In the manuscript the reading would be:

“In the beginning God created the heaven and the earth. BUT (Hebrew “waw”) the earth was (became) without form, and void;”

2. “Hayah.” The Hebrew for “was” is “hayah.” We reiterate, it is important to distinguish whether the verb “was” is in the manuscript, or if it has been inserted by the translators. The King James translators have made this distinction clear for the reader. When “was” appears in the text not italicized, that indicates it is in the Masoretic Text.

When you see “was” italicized, it indicates it does not appear in the manuscripts, but is understood. That is the beauty of the King James Translation.

Now, let us observe Genesis 1:2 where the verb “was” appears twice: first, as part of the Masoretic Text; and, second, as italicized, and not in the original text.

“And (BUT) the earth was without form, and void; and darkness was (italicized) upon the face of the deep...”

In the Hebrew, the order of the words in a sentence is also important. When the verb is in the original text and follows the subject in the sentence, it indicates a change of tense and should be translated as “became” or “had become.” It is a change of something existing from what it had been. Since the earth had already been created in Genesis 1:1, the verb “hayah” being in the original text and following the subject, this indicates a change had occurred with the earth after its original creation. Since a change in the earth had already taken place in the past, the verb “hayah” translated “was” should have been translated “became” or “had become,” because it is in reference to a past event.

Remember, when the verb “hayah” is in the original text and

XVII. Young Earth, A False Doctrine

follows the subject, it indicates a change of thought, event, or of something that had previously existed; but, now has changed.

Notice the second “was” in Verse 2 is italicized, showing it is not in the original. Let us read the last part of Genesis 1:2 as it would read in the original:

“...and darkness (was is omitted) upon the face of the deep.”

It appears the reason that the Hebrew “hayah” or English “became” is not in the original text between darkness and upon in Verse 2 is because darkness is included as part of the earth’s becoming without form and void. In other words, when God judged the earth and rendered it “without form and void,” darkness was part of that judgment. Therefore, the Holy Spirit saw no reason to use a verb concerning darkness as a separate judgment, as it was part of the original judgment of the earth becoming “*without form and void.*” It was not a separate judgment from “*without form and void.*”

May it also be noted that the Hebrew verb “hayah” is also translated “BECAME” in Genesis 2:7, as well as many other places in the Old Testament.

“And the LORD God formed man out of the dust of the ground, and breathed into his nostrils the breath of life; and man BECAME a living soul.”

Note: The young earth advocates refuse to acknowledge the mistranslation of the Hebrew verb “hayah” as “was” instead of “became” or “had become.” The reason is, should they acknowledge and concede to the correct translation from the Hebrew text, it would blow to pieces, like an atomic bomb!, their false hypothesis of a young earth. This is the reason they keep advocating to their readers and listeners to “Just read it as it is in the English; or, as they call it, “a plain reading.”

Their theory they want you to believe is that in Genesis 1:1, when God created the heavens and the earth; that He created it in a ruined, uninhabitable condition, “*without form and void.*” To

XVII. Young Earth, A False Doctrine

promote this false hypothesis, they must convince you to accept the mistranslation of the Hebrew verb “hayah” as “was” instead of “became” or “had become.” Their theory also contradicts Isaiah 45:18, as God’s Word is very specific that He *did not create* the earth in a ruined condition, “without form and void.”

“For thus saith the LORD that created the heavens; God himself that formed the earth and made it; he hath established it, he created it NOT IN VAIN, HE FORMED IT TO BE INHABITED: I am the LORD, and there is none else.”

The word “vain” is the Hebrew “tohuw,” pronounced “to-hoo” and means, “to lie waste, desolation, wilderness, and without form” The young earth philosophy has no credibility when compared to the light of God’s Word. After reading a volume of their material from several different men, in my opinion, I deplore the trickery, shrewdness and deceit used to advocate their hypothesis. More will be said later concerning what some of these advocates really believe concerning their theology and some that will not reveal what they do believe.

May I introduce to you one of the many Bible expositors of the past who believed the Scriptures that refute the young earth advocates. His name is Arthur W. Pink. He was born in Nottingham, England, and died in Sternway, Scotland, in 1951. His wide-spread ministry included pastorates in Australia and the United States. He originated “Studies in the Scriptures,” a monthly magazine concerned solely with the exposition of Scripture. He was the author of many excellent books. One of these being “Gleaning in Genesis.” This work was copyrighted in 1922 by the Moody Bible Institute of Chicago. I will quote from his book on Pages 10,11, concerning his analysis of Genesis 1:1,2.

“Certainly, the earth on the morning of its creation, must have been vastly different from its chaotic state as described in Genesis 1:2. “And the earth was without form and void” must refer to a condition of the earth much later than what is before us in the preceding verse. It is now over a hundred years ago since Dr.

XVII. Young Earth, A False Doctrine

Chalmers called attention to the fact that the word “was” in Genesis 1:2 should be translated “became,” and that between the first two verses of Genesis 1 some terrible catastrophe must have intervened. That this catastrophe may have been connected with the apostasy of Satan, seems more than likely; that some catastrophe did occur is certain from Isaiah 45:18, which expressly declares that the earth was not created in the condition in which Genesis 1:2 views it.

What is found in the remainder of Genesis 1 refers not to the primitive creation, but to the restoration of that which had fallen into ruins. Genesis 1:1 speaks of the Original Creation; Genesis 1:2 describes the then condition of the earth six days before Adam was called into existence. To what remote point in time Genesis 1:1 conducts us, or as to how long an interval passed before the earth “became” a ruin, we have no means of knowing; but if the surmises of geologists could be conclusively established, there would be no conflict at all between the findings of science and the teaching of Scripture. The unknown interval between the first two verses of Genesis 1, is wide enough to embrace all the prehistoric ages which may have elapsed; but all that took place from Genesis 1:3 onwards transpired less than six thousand years ago.

“In six days the Lord made heaven and earth, the sea, and all that in them is.” (Exodus 20:11). There is a wide difference between “creating” and “making”: to “create” is to call into existence something out of nothing; to “make” is to form or fashion something out of materials already existing. “In the beginning (whenever that was) God created the heaven and the earth”; subsequently (after the primitive creation had become a ruin) “the Lord made heaven and earth, the sea, and all that in them is.” This Exodus Scripture settles the controversy which has been raised as to what kind of “days” are meant in Genesis 1, whether days of 24 hours, or protracted periods of time. In “six days,” that is, literal days of twenty-four hours duration, the Lord completed, work of restoring and re-fashioning that which some terrible catastrophe had blasted and plunged into chaos.”

He further states on Pages 11 and 12.

“Rather must it be the part of scientists to bring their declarations into accord with the teaching of Genesis One, if they are to receive the respect of the children of God.” (Page 11).

XVII. Young Earth, A False Doctrine

"In like manner, if the teachings of Science square with Scripture, that goes to show the former are correct; if they conflict, that proves the postulates of Science are false." (Page 12).

11. The Remodeling

We have previously discussed the difference between "created" (Hebrew "bara") and "made" (Hebrew "asah"). To briefly refresh your memory; "created" means that God created something that at no time in the past had ever existed. "Made," on the other hand means "to form, assemble, and arrange from its previous state of usefulness to that form of beautification, so as to be used by God for His purpose."

It is interesting to notice that from Genesis 1:1 where God created the heavens and the earth; the word "created" (Hebrew "bara") does not appear again until the Fifth Day in Verse 20. Everything from Verse 2 to Verse 19 has to do with remodeling the earth in four days. These elements had previously been associated with the Original Creation, where Lucifer and the angels resided. Lucifer's sin brought about God's judgment on the earth, rendering it "*without form and void.*" The angels are now disembodied spirit beings, leaving the earth uninhabitable and in a chaotic ruin. Now let us see what elements, which were previously created and were with the Original Creation, that God is now going to reactivate and position in His remodeling process.

1. Water. - Nowhere does it say from Verses 2 to 19 that water was created to be used as part of the renovation of the earth. Why would that be? Very simply, because water had already been created and in existence at the Original Creation. Notice in Genesis 1:2, it was water that God used to cover the earth as part of His judgment on the Original Creation (Genesis 1:2). God had all the water He had previously created, He didn't need any more. If you will notice, on the Second Day of His renovation, that there was so much water that He had to divide it,

XVII. Young Earth, A False Doctrine

as recorded in Verses 6,7.

"And God said, Let there be a firmament in the midst of the WATERS, and let it divide the WATERS from the WATERS." (6)

"And God made (not created) the firmament, and divided the WATERS which were under the firmament: and it was so." (7)

The fact is, water had already been created, possibly millions of years ago, when God originally created the earth. The proof is, that the earth in its ruined condition was covered with water as found in Verse 2, before He ever started to renovate the earth in the first four days. Therefore, in Genesis 1:6,7, God very simply and precisely stated, He is separating the waters, repositioning them, leaving some on the earth, putting some in the clouds, etc. This is God's renovation in action on the Second Day. The same water He used in judgment of the Original Creation, He is now repositioning to support the human life, aquatic creatures, and animal life that will appear in the Fifth and Sixth Days.

2. Light. The existence of light has caused a big problem to the skeptic and infidel. Their basic reasoning is, on the First Day God said, *"Let there be light: and there was light;"* but, light was not created until the fourth day when God created the sun, moon, and stars. These atheists pride themselves in their so-called wisdom; thus advancing their claim that the Bible is just a "story book" made up by man, who contradicted himself concerning light that existed on the First Day, before it was created on the Fourth Day. In other words, How can there be light before God created light?

The first thing I would like to point out is that God never said he CREATED light on the First Day, or the Fourth Day. Nowhere can you find the word "created" concerning this in the English Text, nor can you find it in the Hebrew Masoretic Text. The Hebrew for "created" is "bara" and is not found used in reference to the First or Fourth Day of remodeling the earth. Maybe these intellectuals should brush up on their reading of

XVII. Young Earth, A False Doctrine

English and Hebrew, before they share all their wisdom with us!
Enough of that!

12. The First Day of Remodeling.

Genesis 1:3-5.

Here is the Record:

"And God said, Let there be light: and there was light." (3)

*"And God saw the light that ("it was" not in the original) good:
and God divided the light from the darkness." (4)*

*"And God called the light Day and the darkness he called Night.
And the evening and the morning were the first day." (V.5).*

In Verse 3, "*Let there be light*" would be better put into English as "Allow there to be light," as "Let" in the Hebrew means "to release or to allow." Since God did not create light, then where did it come? It had to exist in order for God to release and allow it to be observed as the substance that it is—light. Since God did not create light on the first day, it must have always been. Therefore God, Who has always been, as we are going to see, is that light.

In Psalms 4:6; 89:15 and 90:8 it is recorded, in part in each verse, these words, "*...in the LIGHT of thy (God's) countenance.*" Everything God is, is light Himself. His light, concerning Himself, is not limited to Himself, internally; but, flows externally, lighting up everything that exists. Only when He restrains His own light from illuminating, does darkness occur.

We have an example of God's light, lighting the Second Jerusalem, a city prepared for the redeemed. It is 2/3 the size of the United States, coming down from God out of Heaven. Here is the record of God's Word in Revelation 21:22,23,25:

"And I saw no temple therein: for the Lord God Almighty and Lamb are the temple of it. And the city had no need of the sun, neither of the moon to shine in it: for the glory of God did LIGHTEN it, and the Lamb is the LIGHT thereof. ...And the

XVII. Young Earth, A False Doctrine

gates of it shall not be shut at all by day: for there shall be NO NIGHT there."

Concerning God's light, Revelation 22:5 further states,

"And there shall be no night there; and they need no candle, neither light of the sun; for the Lord God giveth them light: and they (the saved) shall reign for ever and ever."

May we also take notice of 1 John 1:5 which speaks of God's light.

"This is the message which we have heard of him, and declare unto you, that God is light, and in him is no darkness at all."

With this in mind, let us go back to Genesis 1:2 and notice that when God's judgment rendered the earth without form and void, it also included withdrawing the light and leaving the earth in total darkness. There were two light "switches," so to speak, that had to be shut off. Therefore, the sun, moon, and stars, which had previously been created, were to light the Original Creation. God had rendered them inactive, thus shutting off the first "switch" of light.

Yet, God's light from Himself would have radiated an ever enveloping and continuous light upon the Original Creation. God, therefore, threw the second "switch, placing a barrier by His Word; refraining His light from illuminating the earth; thus leaving it in a chaotic condition and completely surrounded by darkness, as found in Verse 2 of Genesis One.

13. Second Day of Remodeling. – The Firmament

Genesis 1:6-8.

"And God said, Let there be a firmament (i.e. expanse) in the midst of the waters, and let it divide the waters from the waters." (6) "And God made (Hebrew "asah") the firmament and divided the waters which were under the firmament from the waters which were above the firmament; and it was so." (7) "And God called the firmament Heaven. And the evening and the morning were the second day." (8)

XVII. Young Earth, A False Doctrine

In these verses there are two distinct acts that are recorded. The first act being that the firmament (i.e. expanse) is made, NOT created. The second act was that the waters were divided from each other. May we pause to refresh your memory concerning the meaning of the Hebrew words of "create" and "made." Create is the Hebrew "bara" and means creating or bringing into existence something that had not previously existed. "Made," on the other hand, is the Hebrew "asah" and means: "to manufacture, to form, to release from restraint, or reassemble. The Holy Spirit wanted it known that this expanse, i.e., "firmament," had previously been created and was in use with the Original Creation. Remember, your young earth advocates do not want you to believe this.

God was now going to use the firmament to divide the waters, making two bodies of water, the atmospheric and the terrestrial.

The Hebrew word for firmament is "raqia." It appears in the Old Testament in the Hebrew manuscripts seventeen times, nine of which are in the first chapter of Genesis, and refer to the starry heavens, so to speak. As to the heavens beyond the earth's atmosphere, we are told in Verse 14,

"And God said, Let there be lights (i.e., sun, moon, stars) in the firmament of the heaven..."

The firmament also includes the earth's atmosphere as we find in Verse 20.

"...and fowl that may fly above the earth in the open firmament of heaven."

14. Third Day of Remodeling; Ocean Is Formed;

Dry Land Appears; Botany Is Re-Born.

Genesis 1:9-13.

"And God said, Let the waters under the heaven be gathered together unto one place, and let the dry land appear: and it was

XVII. Young Earth, A False Doctrine

so." (v.9). "And God called the dry land Earth; and the gathering together of the waters called he seas: and God saw that it was good." (v.10). "And God said, Let the earth bring forth grass, the herb yielding seed, and the fruit tree yielding fruit after his kind, whose seed is in itself upon the earth: and it was so." (v.11). "And the earth brought forth grass, and herb yielding seed after his kind, and the tree yielding fruit, whose seed was in itself, after his kind" and God saw that it was good." (v.12). "And the evening and the morning were the third day." (v.13).

Notice carefully that on the third day God did not use the Hebrew word "bara" translated "created" in our English. "Bara," as you recall means something that previously had not existed. In the third day of remodeling the earth, it had already been created in Genesis 1:1 and water had later covered it in judgment, as found in the Third Day. This is the condition that resulted from Satan's rebellion and God's judgment upon the Original Creation; thus, the earth "had become without form and void," as recorded in Genesis 1:2.

Your young earth advocates, some of them writing as though they were Bible scholars, do not have any degrees in Biblical theology at all. Mr. Ken Ham, founder of "Answers in Genesis (AIG) denies the Original Creation occupied by Satan and the angels. He refuses to acknowledge the Hebrew Masoretic Text and what qualifies as a disjunction, instead of a conjunction, and the rules of Hebrew.

For example, In Genesis 1:2, "*And the earth was without form and void...*" Here the Hebrew verb "Hayah" or "was" is in the original, as it is not italicized. "Was," is the Hebrew verb "hayah." When "hayah" is in the original text, and the normal word order of the sentence in the Hebrew is changed, with the subject going to the head of the sentence. Thus a disconnection, or change of thought, is emphasized. This is called a pluperfect tense of the verb. Therefore, the verb "hayah" translated "was" should have been translated "had been" or "had become" or "became" without form and void. Therefore the Hebrew requires

XVII. Young Earth, A False Doctrine

a disjunctive, instead of a conjunctive, since the verb "hayah" is in the original text.

Mr. Ham either denies the word of God outright in the original text, or doesn't know enough about the Hebrew Text to know what it teaches. In trying to deceive people into believing his young earth philosophy, he states that, "God says that when he made the earth, it was first of all covered with water." The Bible says nothing about the earth being created completely covered with water. God says just the opposite, Mr. Ham, in Isaiah 45:18. Here is the word of God:

He (God) created it (earth) not in vain " (i.e., "a wilderness or ruined condition"), he formed it to be inhabited."

This is how he created it, Mr. Ham, not completely covered with water. as you say; but, beautiful and fit for the habitation of God's anointed cherub and his angelic host. This is in perfect harmony with Genesis 1:2, which tells how the earth became after Satan's fall and God's judgment.

"And the earth became (Hebrew verb "hayah") without form and void; and darkness was upon the face of the deep. And the spirit of God moved upon the face of the waters."

I have a booklet entitled Dinosaurs and the Bible, by Ken Ham, B. App. Sc., Dip. Ed. I do not see any degrees concerning Biblical Theology. No Bachelor of Theology, no Master of Theology, nor a Doctorate of Theology. No biblical studies in Hebrew or Greek, yet Mr. Ham presents himself as a Biblical authority of the Scriptures. Unbelievable!

15. Botany Not Created; But, "Brought Forth"

"And God said, let the earth bring forth grass, the herb yielding seed, and the fruit tree yielding fruit after his kind, whose seed is in itself, upon the earth, and it was so." (Genesis 1:11)

Genesis 1:11 took place on the Third Day when God was remodeling the Original Creation. There is to be noted that nothing was created on the Third Day. Remember, "created" is the Hebrew word "bara" which means "something which has

XVII. Young Earth, A False Doctrine

never existed previously." Therefore, "created" is not used concerning the grass, herb and fruit trees; as they had previously been created with the Original Creation of the earth in Genesis 1:1.

When Lucifer and the angels (demons, as we know them today) inhabited the Original Creation, it flourished with grass, herbs and fruit trees, etc. The seed was in itself upon the earth, just as it is today. When God judged the earth, which was brought about by Lucifer's rebellion, the earth was completely covered with water and "*without form and void,*" as stated in Genesis 1:2. The seed of the grass, herb and fruit trees was still in the ground; but, could not grow, or reproduce, due to complete darkness and the earth being completely covered with water, etc.

Now, notice what the word of God says in respect to the plant life.

"And God said, let the earth bring forth grass, the herb yielding seed, and the fruit tree yielding fruit after his kind..."

Let me ask you, how can the earth bring forth something it doesn't already have? The Original Creation had the seed of plant life within itself. These seeds lay dormant for, possibly millenniums; or even millions of years. When God began to remodel the earth for human habitation, He brought forth light on the First Day, as we have discussed previously. On the Third Day, dry land appeared. The seeds of plant life contained in the earth could now, as God said, "*bring forth*" your fruit. God had removed the two obstacles which prohibited the growth of all plant life. Water was replaced with dry land, and light replaced darkness. No one had to replant the olive tree from which Noah's dove plucked a leaf to bring back to him in Genesis 8:11.

May I recapitulate back to the Original Creation in Genesis 1:1, where plant life originated. Whatever bodies Lucifer and the angels possessed, would they not have the privilege to enjoy the fruit trees, etc. Animals were also existent on the Original Creation. (We will cover this when we reach the Fifth Day of

XVII. Young Earth, A False Doctrine

remodeling the earth.) I don't know of any living creature or human that doesn't eat something to maintain existence. Christ not only ate in His earthly body; but also after His Resurrection in His resurrected, glorified body. Dr. Luke records in Luke 24:42,43 concerning Christ.

"And they gave him (Christ) a piece of broiled fish, and of an honeycomb. And he took it, and did eat before them."

Even the manna given to Israel in the wilderness was said to be "angel's food." Could it be that the angels of God enjoy eating the sweet tasting manna in heaven, which God shared with Israel in the wilderness? (Psalm 78:24,25).

Did not the two angels who were sent to Sodom to meet with Lot, eat at his house? Notice in Genesis 19:3.

"And they (the two angels)...entered into his (Lot's) house, and he made them a feast...and they did eat."

Then, there is a river flowing out of the throne of God, and on either side, a tree of life. This tree produces fruit every month. (Revelation 22:1,2). The redeemed in their glorified bodies will have the privilege to eat and enjoy this literal fruit. Personally, I sure hope that at least one of the months, this tree produces those big avocados, like they grow in Florida.

Now, back to Lucifer, the angels, and the Original Creation. There would be no reason for the plant life, herbs, grass, fruit trees, etc. to be created with the Original Creation, unless God had a purpose for them. The word "herbs" is the Hebrew "eseb" and means, "endive, lettuce, any green thing or any tender sprout. Lucifer and the angels could, and did, enjoy eating the herbs and fruit of the fruit trees. Grass would be food for many of the animals.

The seeds of botany that had lain dormant in the earth, while under God's judgment; in the remodeling of the earth would be free to bring forth (produce again), after their kind. They were now liberated from God's curse on the Third Day of His

XVII. Young Earth, A False Doctrine

remodeling of the earth.

Psalm 104:14 tells us that;

"He causeth the grass to grow for the cattle, and herb for the service of man: that he may bring forth food out of the earth."

Notice carefully, that God is going to *"cause the grass to grow"* and *"bring forth food out of the earth."* You cannot cause grass to grow, unless the seed is already in the ground. It is the same with all kinds of plants and fruit trees. This is why the Holy Spirit never used the word "bara," i.e., "created" with the Third Day, because the seeds of Botany were already in the Original Creation.

16. The Fourth Day of Remodeling:Lights In The Firmament

Genesis 1:14-19.

(Verse 14) "And God said, Let there be lights in the firmament of the heaven to divide the day from the night; and let them be for signs, and for seasons, and for days; and years."

(Verse 15) "And let them be for lights in the firmament of the heaven to give light upon the earth: and it was so."

(Verse 16) "And God made two great lights; the greater light to rule the day, and the lesser light to rule the night: He made the stars also."

(Verse 17) "And God set them in the firmament of the heaven to give light upon the earth."

(Verse 18) "And to rule over the day and over the night, and to divide the light from the darkness: and God saw the it was good."

(Verse 19) "And the evening and the morning were the fourth day."

May I note, at the outset, the philosophy of the young earth advocates concerning this Fourth Day. Their hypothesis is, that the greater light (sun), the lesser light (moon) and the stars never existed prior to the Fourth Day; but, rather, were created on the Fourth Day. Their philosophy and/or hypothesis is fraudulent and diametrically opposed to God's Word, as we shall see.

They seem reluctant to accept, acknowledge, or differentiate

XVII. Young Earth, A False Doctrine

between, the two different Hebrew words translated into our English as "made" and "create." The Holy Spirit used the Hebrew word "bara" for "created," and a different Hebrew word, "asah," for "made," since both have a different meaning.

"Created" (Hebrew, "bara") basically means that God created something out of nothing which had no previous existence.

"Made," (Hebrew, "asah") basically means that the substance or object, already existing, is "released from restraint; to make; to allow; or to assemble."

Maybe the young earth advocates should have inspired the Old Testament writers, instead of the Holy Spirit; since they adhere not to the Holy Spirit's choice of words. Failure to recognize the difference between "created" and "made" is the cause of their philosophy and false hypothesis, which is founded upon the outright denial and rejection of God's Word.

There are several observations we need to consider concerning the fourth day:

1. The Hebrew "bara," i.e., "created," nowhere appears in Verses 14 to 19 describing the Fourth Day of remodeling the earth. If this word had been used, then the stars, moon, and sun would never have existed prior to the fourth day.

2. Notice in Verse 16, that God used the Hebrew word "asah," or, "made," concerning the moon, stars, and sun. Remember, "asah" in Hebrew means "to release from restraint, to assemble or allow, and etc. In other words, the sun, moon, and stars had previously been created and useful for the Original Creation. The earth contained plant life, grass, trees, vegetation, animals, Lucifer, and God's angels. There were all kinds of life on the Original Creation, which necessitated heat and light from the sun, light from the moon and the stars.

When Lucifer first resided on the earth, there was heaven above the earth, there were clouds, stars, and etc. (Isaiah

XVII. Young Earth, A False Doctrine

14:13,14). Lucifer's sin brought God's judgment, and these elements were rendered inoperative and stayed that way until God decided to activate them again. They were then placed in their proper position for the sustaining of human life.

Isaiah speaks of God's omniscience and omnipotence concerning *his renovation of an earth that was "without form and void."* It truly is God,

"Who hath measured the waters in the hollow of his hand, and meted out heaven with the span, and comprehended the dust of the earth in a measure, and weighed the mountains in scales, and the hills in a balance." (Isaiah 40:12)

3. In Verse 14, *"God said, let there be lights in the firmament."* May I call your attention to the word "lights" in this verse. The Hebrew for our English "lights" in this verse is "ma-or," which means "luminary, light container, or light holder." In other words, for the sake of clarity, should a paraphrase be rendered, it would read, "On this fourth day God spoke and said, "Let the light containers be released from restraint and be secured in the firmament of the heaven."

Remember, the Holy Spirit was very selective in his choice of Hebrew words, as He never used "created" (Hebrew, "bara") with any of the first four days in His remodeling of a ruined earth. But, rather, God used the word "MADE" (Hebrew "asah"), which means "to release from restraint." When God judged the Original Creation and rendered it *"without form and void,"* the light holders, the sun, moon, and stars were of no more use and were restrained and rendered inoperative. Their original purpose for which they were created was now useless, as there was no life of any kind left on the earth to support. This previous life included grass, herbs, trees, all kinds of vegetation, animals of many kinds, which could have, and without doubt, included dinosaurs.

From God's judgment of the Original Creation until He decided to remodel it for the habitation of Homo Sapiens, there

XVII. Young Earth, A False Doctrine

could have been hundreds of thousands of years; or, even millions of years. Whatever length of time elapsed, it was much more than enough time for many of these animals to have fossilized, including the various dinosaurs.

It is a sad plight when some of these young earth advocates spend more time excavating in the ground than they do digging into the Word of God! Their hypothesis is disastrous, as they continually try to adjust the Bible to fit their findings.

17. The Fifth Day of Remodeling.

Genesis 1:20-23. Replenishing The Earth With Aquatic Creatures and Fowl

(20) "And God said, Let the waters bring forth abundantly the moving creature that hath life, and fowl that may fly above the earth in the open firmament of heaven."

(21) "And God created great whales, and every living creature that moveth, which the waters brought forth abundantly, after their kind, and every winged fowl after his kind: and God saw that it was good."

(22) "And God blessed them, saying, Be fruitful, and multiply, and fill the waters in the seas, and let fowl multiply in the earth."

(23. "And the evening and the morning were the fifth day."

Notice in Verse 21 where the word "created" is used. This fifth day marks only the second appearance of this word in the first chapter of Genesis. Remember, "created" is the Hebrew "bara," which means to create something which had no previous existence. This word is never used in the first four days of remodeling the earth for human habitation. Not until this fifth day is God going to create something that had no previous existence.

It is in connection with this appearance of biological life, quite naturally, that the Hebrew "bara" again makes its appearance. It is on this day that the Creator originates all of the many varieties that dwell in the waters AND the entire realm of

XVII. Young Earth, A False Doctrine

bird life. By the Holy Spirit's use of the Hebrew "bara," it is evident that no aquatic or bird life ever existed on the Original Creation. Should there have been, then God would have used the Hebrew "asah" (i.e., English "made") instead of the Hebrew "bara" (i.e., English "created").

Timothy tells us why just exactly the correct Hebrew words are used without a mistake or contradiction.

"For all scripture is given by the inspiration (i.e. God-breathed) of God..." (2 Timothy 3:16).

"For the prophecy (i.e., the word of God) came not in old time by the will of man: but holy men of God spoke as they were moved by the Holy Ghost." (2 Peter 1:21).

Prior to the fifth day, vegetation was the only kind of life existing. It becomes apparent to even the casual observer that plants must precede the birds and animals, or there will be no source of food for them. Therefore, the seed and edible parts of vegetation have a start on those who are to eat them. Thus, we see the omniscience of God in His renovation of the earth.

18. The Sixth Day of Remodeling.

Genesis 1:24-31. Insects, Animals Made, And Man Created.

We have, here on the sixth day, a precise distinction of the two Hebrew words, "asah" ("made") and "bara" ("created"). We will examine the verses that deal with these two words.

First, we will look at what God made on this sixth day, that had previously existed on the Original Creation. Here is the record as found in Genesis 1:24,25.

(24) "And God said, Let the earth bring forth the living creature after his kind, cattle, and creeping thing, and beast of the earth after his kind: and it was so."

(25) "And God MADE (Hebrew "asah") the beast of the earth after his kind, and cattle after their kind; and every thing that creepeth upon the earth after his kind: and God saw that it was very good."

In introducing God's work on this sixth day, let us make a

XVII. *Young Earth, A False Doctrine*

textual examination concerning the phrase in Verse 24 which states: "*Let the earth bring forth.*" Some evolutionists claim that the approximately 92 elements in the earth are the seed plot from which insects and animal life began to evolve. These evolutionists continually "**strain a gnat and swallow a camel!**" A typical example of years ago is from the pen of Dr. Edwin O. Jordan in the famous symposium published by sixteen university professors of Chicago, bearing the imposing title, "The Nature of the World and of Man." Here are a couple of their statements.

"While there is little or no cause to believe that spontaneous generation is occurring at the present day, it is reasonable to suppose that some form of microscopic life developed out of the inorganic matter at some previous period in the world's history."

"We naturally have no direct evidence about the origin of bacteria on the earth, but it is quite in line with all of our other knowledge of life development to suppose that at some time, in some way, some form of microscopic life developed out of highly organized, but up to that time, inorganic matter."

That is the pseudo-evolutionary philosophy of sixteen university professors that deny the word of God; and all they can project is "we suppose," "no cause to believe," and "no direct evidence." What a joke!

In answer to this asinine philosophy, may I state that, in fact, no growth, no reproduction, no generation, and no quickening of inorganic matter has ever been demonstrated in any field of Science whatsoever.

May God say a word to these evolutionists as found in Psalm 14:1.

"The FOOL hath said in his heart, There is no God. They are corrupt, they have done abominable works, there is none that doeth good."

Now, back to the statement in Verse 24, "*Let the earth bring forth.*" This does not imply creative forces in the soil or in any of the physical elements. The 92 elements have been in existence from very first verse in Genesis One, when...

XVII. Young Earth, A False Doctrine

"In the beginning God created the heaven and the earth."

May we recapitulate by quoting Verse 25 once again.

"And God MADE (Hebrew "asah") the beast of the earth after his kind, and cattle after their kind; and every thing that creepeth upon the earth after his kind: and God saw that it was very good."

Notice carefully that God made the cattle, the beast of the earth and every creeping thing. The Holy Spirit did not use the word "create" (Hebrew "bara"). Since "bara" means creating something which had no previous existence, whereas "made" (Hebrew "asah") is used as bringing forth something that had previously existed, by the usage of the Hebrew word "asah"; the Holy Spirit let us know that these beasts, cattle and all manner of creeping things had previously existed on the Original Creation. Now God lets us know that these creatures are again going to inhabit the renovated earth where man is going to reside.

All these young earth advocates do is *talk* about going back to the authority of God's word. This is only a smoke screen, evidenced by their refusal to point their followers to the difference between the Hebrew words for "created" and "made." Should they believe the original Hebrew text, their young earth theory would evaporate.

I find that some of your young earth speakers have no studies in the Greek or Hebrew. Some won't even tell you what church they attend, let alone what their Theology is. When I read of their education, it is primarily a secular degree, not a Bible degree of any kind. Yet these same men project themselves as authorities on the Bible. Unbelievable! Their smoke screen is that if you do not agree with their young earth philosophy, then you are not standing on the authority of God's Word. This is another one of their lies they want you to accept.

An example of a young earth speaker who has joined the staff of "AIG" or, Answers in Genesis, founded by Ken Ham, is one Mike Riddle. In their newsletter of February 2005, we are

XVII. Young Earth, A False Doctrine

informed that Mr. Riddle will be holding special meetings in churches, schools, and workshops in the new AIG facility near Cincinnati, Ohio. Mr. Ham states that Mike will be giving talks on topics such as, "The importance of upholding Biblical authority." What this biblical authority means is (as we have stated before), that if you do not believe in their "young earth philosophy," then you are not standing on the Word of God.

Now, here are the qualifications of Mike Riddle, who presents himself as a Biblical scholar:

1. He is a former world-class athlete in the Decathlon.
2. He is a dynamic and passionate speaker, with a wealth of experience in Creation ministry. (See note below).

Note: Creation ministry simply means to teach that the earth is only, give or take a few years, 6,000 years old. He totally denies that the Original Creation was beautiful (Isaiah 45:18), then became "without form and void" (Genesis 1:2) as a result of God's judgment because of Lucifer's sin. The earth could have remained in this chaotic condition for thousands, millions, or even billions of years, as we register time, before God remodeled it for human habitation.

3. He is a mathematician with a graduate degree in education.
4. He was a U.S. Marine, rising to the rank of Captain.
5. He became a U.S. national champion in the track and field version of the Pentathlon.
6. Mike worked for many years in the computer field with Microsoft.

This is amazing! This man presents himself as an authority on the Bible and the Creation in Genesis One; yet I find no degrees of any kind concerning the Bible. There are no degrees from any Bible Colleges, no home-study courses, no studies in Hebrew, nothing!

XVII. Young Earth, A False Doctrine

This reminds me of the lady who advertised for one of the fast-food chains, and used to scream "Where's the beef?" May we ask the same. Where are the degrees in Biblical studies and Theology or Etymology, etc.? I hardly think that working for Microsoft concerning computers, running track, being a captain in the Marines, having a degree in Education, being an athlete in the decathlon, and having a good reputation as a speaker would be qualifications for anyone to claim themselves as an authority on the Bible. This man has followed the crowd, which cannot even discern the difference between "created" and "made" in Genesis, Chapter One.

"After Their Kind"

I have been contemplating whether or not I should expand our study a little further concerning the words *"after their kind."* Well, I guess one can only be double minded so long, until he has to make a decision one way or the other. So, I have decided to proceed by getting right to the point, without a lot of biblical "jargon."

When *"after their kind"* is associated with the word "created" (Hebrew "bara") in Genesis One, it has a different meaning in reference to the context, than it does when used with the word "made" (Hebrew "asah"). Let's look at Verse 21 which appears in reference to the fifth day of re-creation.

"And God created (Hebrew "bara") great whales, and every living creature that moveth, which the waters brought forth abundantly, AFTER THEIR KIND, and every winged fowl AFTER HIS KIND: and God saw that it was good."

The word "created" let us know that whales, all creatures in the waters and fowl never existed on, about, or with, the Original Creation, but only came into existence on the fifth day. Since they never existed before; *"after their kind"* is referring to their reproduction and NOT to God making something that had previously existed, as he did on the sixth day concerning the beasts, cattle, and creeping things. This is the difference when

XVII. Young Earth, A False Doctrine

"*after their kind*" is used with "created" (Hebrew "bara"); than as used in reference to the word "made" (Hebrew "asah").

Of the commentaries I possess, I have not found one that makes this distinction. I am not saying this in a critical manner; but, only as a fact. Maybe this little point will encourage the Bible student to study the Bible instead of just casually reading it. Joshua 1:8 says to "meditate" concerning the Word, i.e., digest what you have read. Psalm 1:2 says the same. Now let us recapitulate and summarize the two verses in context, concerning "*after their kind*."

(1) When used with "created" in Genesis 1:21, this shows us that what was created on the fifth day never existed previously in the Original Creation; therefore, "*after their kind*" is in reference to these species reproducing offspring of the same species.

(2) When used with "made" in Genesis 1:25, this is referring to replenishing the renovated earth with the same animals and creatures God had created and placed on the Original Creation.

"Created" and "Made" Concerning Adam and Eve.

Both "created" and "made" are used in reference to Adam and Eve being brought into existence. the question naturally arises as to how we can reconcile these two words as pertaining to God's creation of Adam and Eve. Before we examine the verse that uses "created" and "made," let us again look at their respective meanings:

(1). "*Created.*" (Hebrew, "bara"). Shows us that God created something that had never previously existed in any form whatsoever.

(2). "*Made.*" - (Hebrew, "asah"). This Hebrew word means "to release from restraint, to make, to allow, or to assemble." In the making of Adam and Eve, this would apply in the material (physical) sense, as well as their spiritual makeup.

XVII. Young Earth, A False Doctrine

Now, let us examine the verses that contain both words in reference to Adam and Eve. They are found in Genesis 1:26,27 and Genesis 2:7,22.

"And God said, Let us MAKE man in our image, after our likeness... (Genesis 1:26)."

"So God CREATED man in his own image, in the image of God CREATED he him; male and female CREATED he them. (Genesis 1:27)."

"And the LORD God FORMED man of the dust of the ground, and breathed into his nostrils the breath of life; and man became a living soul (Genesis 2:7)."

"And the rib, which the LORD god had taken from man, MADE he a woman, and brought her unto the man (Genesis 2:22)."

"Created." Mankind has never existed before at any time prior to Adam and Eve. Notice Genesis 1:27 which reveals to us, by the use of the Hebrew "bara" (created), that God has never previously created anything in His likeness or in His image, such as a human being. The image of God that man possesses is not the physical appearance of God for *"God is spirit: and they that worship him must worship him in spirit and in truth."* Rather, therefore, they are the spiritual qualities that a thinking, intelligent, human being possesses, such as: mind, personality, will, emotions, conscience and etc. Other terminologies for these are labeled, "heart," "soul," and "spirit."

(1). **"Heart."** The seat of your conscience and reasoning. Romans 2:15,

"Which shew the work of the law written in their hearts, their conscience, also bearing witness, and their thoughts the mean while accusing or else excusing one another."

Mark 2:6, "But there were certain of the scribes sitting there, and reasoning in their hearts."

(2). **"Soul."** The seat of one's emotions and appetites. Our soul can hate (2 Samuel 5:8); mourn (Job 14:22); rejoice (Isaiah 61:10); suffers (Genesis 42:21); sorrows (Mark 14:34); and desires (Deuteronomy 12:20).

XVII. *Young Earth, A False Doctrine*

(3). "Spirit." is the seat of one's intelligence. 1 Corinthians 2:11 tells us,

"For what man knoweth the things of a man, save the spirit of man which is in him? Even so the things of God knoweth no man, but the Spirit of God." (Also Verse 4).

Therefore it is made perfectly clear, by the use of the Hebrew word "bara", that God has never previously created any species of Homo Sapiens. In Psalm 115:16, the Lord lets us know that,

"The heaven, even the heavens, are the LORD'S: but the earth hath he given to the children of men."

God has also made it clear to the evolutionists that mankind possesses something that animals do not possess, and never will! It is called, Mr. Evolutionist, SPIRIT, which is intelligence. Job 32:8 states:

"But there is a spirit in man: and the inspiration of the Almighty giveth them understanding."

We find in Psalm 32:9 that animals do not possess a spirit of intelligence and reasoning, or understanding, such as humans possess.

"Be ye not as the horse; or as the mule, which have no understanding: whose mouth must be held in with bit and bridle, lest they come near unto thee."

I am sorry, Mr. Evolutionist, but I just cannot buy into your pseudo-philosophy that "We slipped from slime or come from scum."

“Even in the simplest science,
You cannot really entertain,
And believe man's interpretation
That out of muck and slime we came.

Our God is truly saddened,
We were created in His image.
We're not monkeys, apes, or exploding cells;

XVII. Young Earth, A False Doctrine

We're from His Holy Lineage.
For it is not your high IQ;
Or, how brilliant that you look.
Your PhD is useless,
If your name's not in His Book!

From the poem, *After His Kind*, by Katherine Higham, Stanzas 7,8,11.

I am sorry, but, again, God says of the evolutionists in Psalm 14:1,

"The fool hath said in his heart, There is no God."

Now, back to the difference between man and animals. Animals have a soul, with emotions and appetites, which is connected with their bodies. They do not possess a spirit of intelligence such as mankind. When an animal dies, their soul and body cease to exist. There is no life after death with animals.

Man has a body, soul, and spirit. In 1 Thessalonians 5:23 we are told,

"And the very God of peace sanctify you wholly; and I pray God your whole Spirit, and soul and body be preserved blameless unto the coming of our Lord Jesus Christ."

When humans die, their soul and spirit separates from the body and goes to Heaven or Hell, as there is no Purgatory, as projected by Roman Catholicism.

“Made.” (Hebrew "asah"). As we have previously set forth, "created" means the instant, miraculous creation of something which had no previous existence in any form whatsoever. "Made," however, is an entirely different Hebrew word which means "to release from restraint, to assemble, or to allow something materialistically, spiritually, and etc. to be used again, as it had previously been used.”

In Genesis 1:26, *"God said, let us MAKE man in our image."*

XVII. Young Earth, A False Doctrine

This, of course, is referring to the spiritual qualities that God wanted man to possess, such as, personality, ability to think intelligently, free will, conscience, emotions and etc.

Since "made" has reference to something that has previously existed, we can readily see that these spiritual qualities have existed before. Did not the angels and their overseer, Lucifer, possess these same qualities? They sure did! Lucifer, the anointed cherub, wasn't satisfied with the Original Creation where he was to reign. Isaiah 14:13,14 describes and shows forth his free will, conscience, thinking ability, emotions and etc.

"For thou hast said in thine heart, I will ascend into heaven, I will exalt my throne above the stars of God: I will sit also upon the mount of the congregation, in the sides of the north:" (13) I will ascend above the heights of the clouds; I will be like the most high." (14)

Here we have the five (5) "I wills" of Lucifer (Satan) who was given his residence on the Original Creation, as recorded in Genesis 1:1, along with the angels. In other words, the same spiritual attributes that God had formed or made Adam and Eve with, had previously existed with Lucifer and the Angels that God had created, possibly millions or even billions of years ago.

Therefore God, the Holy Spirit, directed Moses to use the exact Hebrew word "asah" (made), concerning the spiritual attributes of Adam. The same Hebrew word is used in reference to Eve, concerning something that previously existed. Notice in Genesis 2:22,

"And the rib, which the LORD God had taken from man, MADE (Hebrew "asah") he a woman, and brought her forth unto the man."

Here, the rib had existed before; therefore qualifying the Hebrew "asah" to be used instead of Hebrew "bara" (created), which would refer to something that had never previously existed; i.e., the rib.

Notice that we have the same thing concerning Adam, who

XVII. Young Earth, A False Doctrine

was formed out of the dust of the ground; which would prohibit the use of the word "created" (Hebrew "bara") in reference to this. Here is the record in Genesis 2:7.

"And the LORD God formed (not created) man of the dust of the ground..."

Since "created" has reference to something that had no previous existence, its usage here would be disqualified. The reason is, that man was formed out of something already in existence, that is, *"the dust of the ground."*

Adam and Eve; Both "Created" and "Made"

It may seem at first glance that the words "created" and "made" as used in reference to Adam and Eve may appear contradictory to each other. Since basically "created" has reference to something that had no previous existence and "made" has reference to something that did previously exist; then, how could they be complementary instead of contradictory?

I believe we can summarize very simply how these two words are used in their proper context, as Proverbs 30:5 says, *"Every word of God is pure..."* You see, the words from God to mankind in Genesis were penned by Moses exactly and precisely as the Holy Spirit directed. Therefore, no mistake in the original Hebrew. (2 Timothy 3:16 and 2 Peter 1:20,21).

With Genesis 2:3, God makes it perfectly clear that in His six days of remodeling a ruined and uninhabitable earth, and bringing into existence humanity; that, He used precisely two words to distinguish any false teaching that may arise. One of those being, the pseudo-philosophy of a "young earth of only about 6,000 years old. Here is the record, concerning these two important words in Genesis 2:3.

"And God blessed the seventh day, and sanctified it: because that in it he had rested from all his work which God CREATED (bara) and MADE (asah)."

God makes it perfectly clear concerning the six days of

XVII. Young Earth, A False Doctrine

renovation that He created some things and others He did not create; but, were made. A distinction that God wants us to recognize; or, He would not have used two different Hebrew words, as He stated in Genesis 2:3.

Here we will simplify these two words, as used in reference to Adam and Eve only. A very simple principle to keep in mind is the following: First, where "made" is used in reference to Adam and Eve, it is in reference to something that has existed before. This will be used as PART of the complete embodiment of Adam and Eve. Second, when "created" is used in reference to Adam and Eve, it is always in reference to their completed form as Homo Sapiens, such has never existed before. You will see this as we examine the verses containing "made" and "created."

(1). "And God said, Let us MAKE man in our image, after our likeness." Genesis 1:26.

As you recall, "image" is in reference to the spiritual qualities of mankind such as emotions, free will, personality, thinking, etc. As noted before, these all existed with the angels, ages before. Therefore, "created" meaning "never existed before" would be disqualified.

(2). Notice carefully that God said, "*Let us make man,*" Adam had not existed as yet. Here God is telling us a particular part of what the complete man will possess; i.e., the spiritual qualities which God had previously endowed the angels with when He created them.

*"So God CREATED man in his own image, in the image of God
CREATED he him; male and female CREATED he them."
Genesis 1:27.*

This verse differs from Verse 26 as this is speaking of Adam as a completed creation. Notice here that, "*God created man*" and "*male (Adam) and female (Eve) created he them.*" Here God tells us that he has already created Adam and Eve, body, soul, and spirit. (1 Thessalonians 5:23). Therefore the word "create" is

XVII. Young Earth, A False Doctrine

properly justified as to its meaning of "never previously existing," as there has never existed Homo Sapiens prior to Adam and Eve.

(3). Angels were not Homo Sapiens. We do know that Lucifer and the angels, as we know them, did possess some kind of bodies when they resided on the Original Creation. Ezekiel 28:14 speaks of Lucifer as

"Thou hast WALKED up and down in the midst of the stones of fire."

We do know that all angels are described in the masculine gender and are called "men." There are no women angels.

What kind of material the angel's bodies were composed of, we are not told. Whatever kind of body God created them with was not of the same exact material as we possess today. God lets us know that He can create a body for whatever species He sees fit. In 1 Corinthians 15:38-40 we are told,

But God giveth it a body as it hath pleased him, and to every seed his own body. (38) All flesh is not the same flesh: but there is one kind of flesh of men, another flesh of beasts, another of fishes, and another of birds. (39) There are also celestial bodies, and bodies terrestrial: but the glory of the celestial is one, and the glory of the terrestrial is another." (40)

Whatever species God creates, He gives it a body to function with, exactly as He sees fit. Therefore, the angels had bodies that could talk, walk, and function; but, their bodies were different. It is true that they had the same spiritual attributes as we do; i.e., they had feelings, they had intelligence, and were created with a free will to choose right or wrong. But, their bodies were different.

Keep this in mind, all angels were men! God never created angels to reproduce; therefore, their bodies had no use for organs of sexual reproduction as there were no women angels ever created to reproduce with. Wherefore, our English "created" from the Hebrew "bara" is absolutely correct, as there has never

XVII. Young Earth, A False Doctrine

existed a created being exactly like Homo Sapiens, such as Adam and Eve. Peter states in his second epistle, 2 Peter 2:11 that, "*Whereas angels which are greater in power and might,* " (i.e., than Homo Sapiens).

The foregoing makes it clear that the angels and Lucifer were created prior to mankind and inhabited the Original Creation; which could have been millions or billions of years ago.

After Lucifer's rebellion, the earth was rendered uninhabitable as God states in Genesis 1:1,2,

"And the earth became without form and void, and darkness was upon the face of the deep."

Since it became that way, it is evident it wasn't created that way.

In Isaiah 45:18b we find,

"He (God) created it (earth) not in vain (i.e., a wilderness, a waste, and without form), he formed it to be inhabited: I am the LORD; and there is none else."

It taxes our imagination as to how beautiful God had made the Original Creation for Lucifer and the angels. Ezekiel 28:13 gives a little insight as to its beauty.

"Thou (Satan) hast been in Eden the garden of God; every precious stone was thy covering, the sardius, topaz, and the diamond, the beryl, the onyx, and the jasper, the sapphire, the emerald, and the carbuncle, and gold: the workmanship of thy tabrets and of thy pipes was prepared in thee in the day that thou was created."

Lucifer lost it all because of his rebellion against God. Because of this, his eternal residence, along with the angels that followed him, would be eternal Hell. Matthew 25:41 lets us know that Hell, or the everlasting fire, was originally prepared for the devil and his angels that occupied the Original Creation, long before earth was ever remodeled for Adam and Eve. Matthew also lets us know that those who rebel and refuse to

XVII. Young Earth, A False Doctrine

accept Jesus Christ as their Savior will spend eternity in the Lake of Fire with their father, the Devil.

"Then shall he say also unto them on the left hand, Depart from me, ye cursed, into everlasting fire, prepared for the devil and his angels." (Read also Revelation 20:10).

Your young earth advocates want you to believe that there was no sin before Adam; therefore, denying the Original Creation where Lucifer and the angels resided. If Adam and Eve were the first to ever sin, then why wasn't Hell created for Adam and Eve instead of the Devil and his angels?

We will expound more on this later concerning this false teaching of the young earth advocates, who claim there was no sin before Adam. One must remember that the advocates of this "new" philosophy, that the earth is only about 6,000 years old, appear to have come from a false prophetess, one Ellen G. White.

The young earth advocates claim their interpretation of geology lends support to a 6,000-year-old earth. They absolutely refuse to acknowledge the Biblical teaching of the Original Creation and the gap of time before God remodeled it, fit for human habitation. This gap of time could involve millions or even billions of years.

This, they say, gives the evolutionist the time needed for evolution to take place. This philosophy is the wisdom of men, but not of God, because it denies the Biblical authority of Genesis One. When God—destroyed the Original Creation along with the beast of the earth, the cattle and every creeping thing, He rendered it a desolation, a wilderness and uninhabited!

You will notice, in Genesis 1:25, that the word "MADE" is used of the animals, cattle, and creeping things; not, the word "CREATED." "Made" in the Hebrew means, bringing into existence something that has previously existed (i.e., on the Original Creation). I have stated this to make a very simple point.

XVII. Young Earth, A False Doctrine

How in the world could something evolve, when there was absolutely nothing to evolve from?

"Knocking Down the Straw Man."

So, again, the young earth advocates project another lie; that is, that the Gap Principle allows time for evolution to take place. Wherein the opposite is true. It would make absolutely no difference if there was 100,000, 20,000,000, or 50 billion years between God's judgment on the Original Creation and remodeling it for human habitation. Excluding the angels becoming disembodied spirits, all other forms of life and vegetation were completely destroyed, as Genesis 1:2 states.

"And the earth became without form and void."

Therefore, as I have said before, How can some-thing evolve from nothing when there was nothing to evolve from? This in itself disproves any possibility of evolution having taken place.

All of this young earth philosophy stems from not accepting the Biblical authority of God's Word concerning the Original Creation, and the gap of time before God remodeled it for human habitation. Maybe if some of these men would spend the majority of their time studying the Word of God, instead of digging in the dirt, they wouldn't have to distort the Bible into fitting their so-called geological findings.

19. The Big Lie, No Sin Before Adam

Romans 5:12

"There was no sin before Adam" is the claim and false teaching of the young earth advocates. They base their claim on Romans 5:12 which reads:

Wherefore as by one man sin entered into the world, and death by sin; and so death passed upon all men, for that all have sinned."

Therefore, they claim there was no death or sin prior to Adam. This presents several problems to their philosophy, which

XVII. Young Earth, A False Doctrine

actually contradicts the Word of God.

Before we look at Genesis, Chapter Three, where we find the Serpent in conversation with Eve, we need to understand that this is not a snake or reptile of any kind. This is none other than Satan himself in action. In Revelation 12:9, he is described with four names, the "Serpent," the "Devil," "Satan," and the "Dragon." In Revelation 9:11 he is described by his Hebrew name of "Abaddon," meaning "destroying angel," as well as his Greek name "Apollyon," meaning "destroyer," and that is exactly what he is. If Satan had been an actual reptile, God would have said, "*Now the serpent was more subtil than any {other} beast of the field.*" Instead, his character was being described the same way we would say, "Sly as a fox," Strong as an ox, Brave as a lion, etc.."

(1.) Now let us go to Genesis 3:1-6 where we find Satan trying to get Eve to sin by doubting, and ultimately deceiving Eve into disobeying God. My Bible says that it was Satan, the sinner, trying to get the sinless (Eve) to sin. The record is perfectly clear that **Satan had sinned prior to Adam and Eve;** or, he wouldn't have tempted Eve to sin.

For the young earth philosophy to be true, the Bible would have to proclaim that Eve tempted Lucifer (Satan) to sin, not that he tempted her. Lucifer's personal sin was when he wanted to be equal with God. His residence, along with the angels, was on the Original Creation that God had prepared for them. Isaiah 14:13,14, describes Satan's sinful desires.

"For thou hast said in thine heart, I WILL ascend into heaven, I WILL exalt my throne above the stars of God: I WILL sit also upon the mount of the congregation in the sides of the north: I WILL ascend above the heights of the clouds: I WILL be like the most High."

Because of this, "*the earth became without form and void,*" as stated in Genesis 1:2. It was totally uninhabitable, as it was completely covered with water and darkness as described in

XVII. Young Earth, A False Doctrine

Genesis 1:2. It remained this way for possibly thousands, millions, or even billions of years, until God remodeled it for human life. THEREFORE, EVOLUTION, WAS IMPOSSIBLE, because there was nothing to evolve from!

All of this the young earth advocates deny, in order to perpetuate THE LIE that there was no sin before Adam.

Mr. Ken Ham, president of Answers in Genesis and one of the leaders in the young earth philosophy, is going all out to ensnare and train as many as possible in the philosophy of a young earth. In his monthly publication, Volume 12, Issue 8, Mr. Ham advertises his college of "5 days." This is a quote directly from his advertisement.

"Back by popular demand. CREATION "COLLEGE" II equipping and training creation speakers...with excellence with "Dean" Ken Ham — and a distinguished faculty. June 28 - July 2, 2006 in Harrison, Indiana. Over 600 graduates in 2004. The regular tuition is \$359.00 per person for 5 days of intensive sessions."

This is unbelievable, a "5 day" college course and you are ready and prepared, as a sheep goes to the slaughter, to perpetuate this man's theory of a young earth. Have any of his followers ever questioned Mr. Ham as to what Bible college or University of Biblical studies he has attended and graduated from, or what Biblical studies in Hebrew and Greek he has taken.

When we wrote him, questioning him about his Theology such as:

1. Do you believe you can lose your salvation?
2. Do you believe the Biblical teaching concerning the Rapture?
3. What about the 7-Year Tribulation Period?
4. And the Kingdom Reign of Christ?, and other theological questions.

XVII. Young Earth, A False Doctrine

A representative of Ken Ham's organization advised us that Mr. Ham doesn't get involved in these things, as fighting evolution is his main concern. When a man will not reveal his theological stand on the great doctrines of the Bible, he has something to hide and is a false teacher!

Read the Book of Acts and the 14 Epistles of Paul, and see if he hid or refused to declare what he believed. Of course, if Mr. Ham did as Paul, and decided to be honest with his followers about his beliefs, other than not believing in evolution; and his beliefs were contrary to many, I doubt if they would contribute money to finance his museum. Mr. Ham is wise enough to know that. I can see no other reason for him not to reveal what he really believes concerning the major Bible doctrines; including Eschatology, as set forth so clearly in the Word of God. I have learned many years ago never to follow a man that hides what he really believes.

Further, what are the names of his "distinguished faculty" and what education do they possess in Biblical Theology and the Hebrew language. Did you ever think to ask, or do you just blindly follow this man?

20. No Death Before Adam, Another Lie!

Romans 5:12. The Facts

Eve sinned first.

Let us refer back to the young earth advocate's claim there was no death or sin before Adam, using Romans 5:12 as their so-called proof. Let us look at Romans 5:12 again and see if what they say is true.)

"Wherefore, as by one man sin entered into the world, and death by sin; and so death passed upon all men, for that all have sinned."

XVII. Young Earth, A False Doctrine

The question is, “How did sin enter into the world?” when there was NO world; i.e., offspring as yet? No children yet born, as Adam had not yet sinned. Here is the record in Genesis 3:4,6.

“And the serpent said unto the woman, Ye shall not surely die:

(4)

“And when the woman saw that the tree was good for food, and that it was pleasant to the eyes, and a tree to be desired to make one wise, she took of the fruit thereof, and did eat.” (6)

Eve was deceived; but, nothing is said about Adam being deceived. How true it is that, “The New is in the Old concealed and by the New, the Old is revealed.” So, let us see what the New Testament has revealed concerning Genesis, Chapter Three. We find the record in 1 Timothy 2:13,14.

“For Adam was first formed, then Eve.” (13)

“And Adam was not deceived, but the woman being deceived was in the transgression.” (14)

The Bible clearly teaches that there **was** sin and death before Adam, as described in Genesis, Chapter Three. My Bible teaches that Eve sinned BEFORE Adam. Eve ate **first** and was the **first** to be spiritually dead, also resulting in physical death, as her physical body would later die. So, there **was** sin and spiritual death before Adam.

(a.) What Nature Did Adam and Eve Have? Were Adam and Eve created with a sin nature as every human being now possesses? No. They were not created with a sin nature, as God would be guilty of creating two sinful individuals who had never sinned. God created Adam and Eve with a sinless nature; unlike any other human being ever born. They were created in innocence, which is sinlessness that has never faced temptation or trial.

(b.) What Is Innocence? Innocence is sinlessness that has never faced trial. Righteousness is innocence that has been tested and found victorious. Therefore, when Eve sinned first, and then Adam; that innocent and sinless nature became a sinful nature

XVII. Young Earth, A False Doctrine

which brought forth spiritual and physical death. Their sinful nature was then passed on to their offspring, and to the rest of all humanity.

At this point, Adam had not yet sinned; therefore, he had no sin nature. On the other hand, Eve had been deceived and sinned; therefore possessing a sinful nature which brought death. In this situation, there could be no conception as there would be two conflicting natures in one child. You would have Adam's nature, yet sinless, and unable to die because he had not yet sinned. Eve had already sinned, therewith possessing a sinful nature which required death.

Should conception have taken place at this point in time, their offspring would possess TWO conflicting natures. That is, Adam's sinless nature requiring no spiritual or physical death; while the same child possessed his mother's sinful nature requiring spiritual and physical death. This would produce a monstrosity of a child with two opposite and conflicting natures.

Now, let us go back again to 1 Timothy 2:14 where we are told,

“And Adam was not deceived, but the woman being deceived was in the transgression.”

Since Adam was not deceived, the only other answer is that he purposely partook of the forbidden tree, so that conception and life would continue the human race. In Genesis 3:6b we are told that,

“...she (Eve) took of the fruit thereof, and did eat, and gave also unto her husband (Adam) with her; and he did eat.

Now we have Adam and Eve with a sin nature that will be passed on to all humanity and the Lord can deal with the extent of all humanity on one common denominator. This is spoken of in Romans 3:23,

“For all have sinned, and come short of the glory of God;”

This is a far cry from THE LIE perpetrated by the young

XVII. Young Earth, A False Doctrine

earth advocates that “there was no sin or death before Adam.” As I have said before, this is what happens when so-called scientists spend most of their time digging up and studying rocks, instead of studying and believing the Word of God.

Analysis of Romans 5:12

“Wherefore, as by one man sin entered into the world, and death by sin; and so death passed upon all men, for that all have sinned.” (Romans 5:12)

(a). “As by one man sin entered into the world.”

This is not speaking about Adam being the first to sin, as we have already seen that it was Eve who sinned first. Adam was the first created human and, as such, he was the Federal Head of the human race, meaning he was the representative for the entire human race.

“For Adam was first formed, then Eve. (13) And Adam was not deceived, but the woman being deceived was in the transgression.” 1 Timothy 2:13-14

(b). “...by one man (Adam) sin entered into the world.”

Eve had sinned first, then Adam second. Now the question arises as to how did sin enter into the world by Adam?

Satan Was Already At Work In The Garden

Who met Eve at the tree? Who made the tantalizing suggestions to Eve which are found in Genesis 3:4,5?

“And the serpent said unto the woman, Ye shall not surely die: For God doth know that in the day ye eat thereof, then your eyes shall be opened, and ye shall be as gods, knowing good and evil.”

Creation of Angels Not Mentioned In Genesis

If God had created the angels at any time during the creation week, it would be recorded in the first two chapters of Genesis. It is not. It does not make sense that God could create

XVII. Young Earth, A False Doctrine

Lucifer and he would have time to fall and deceive a third of the angels to follow him, during the week of remodeling. This is not a logical conclusion, since Job 38:4, 7 shows the angels were in existence before the “*foundations of the earth*” were laid.

“Where wast thou when I laid the foundations of the earth? declare, if thou hast understanding. (4) Who hath laid the measures thereof, if thou knowest? or who hath stretched the line upon it? (5) Whereupon are the foundations thereof fastened? or who laid the corner stone thereof; (6) When the morning stars sang together, and all the sons of God shouted for joy ?” (Job 38:4-7).

Evidently the young earth advocates have never read Genesis Three; or, if they have, they disregard it altogether. (Eve sinned before Adam, and Satan was there to entice her.). It is sad the young earth advocates cannot understand a simple verse such as Romans 5:12 and try to make it fit their philosophy; which contradicts Genesis, Chapter 3, concerning Eve sinning first, not Adam.

This is easily answered as Adam and Eve had no ancestors; only descendants. Adam was the first man; but, those who inhabited the original creation were angels.

If Adam had not had conception with Eve, there would have been no future human race. So, by one man (Adam) having conception with Eve, the human race proceeded. Their sin nature was passed on to Cain and Abel and everyone's children, up to the present. Therefore, as by one man (Adam) having conception with Eve, their sin nature entered into their offspring, or “*into the world.*”

Thus, all humanity has inherited the old sin nature, along with “*[the] death [which] has passed upon all men*” in the world; because “*all have sinned*” as a result of the old sin nature, which was inherited from our first parents.

“Wherefore, as by one man (Adam) sin entered into the world (Adam having conception with Eve), and death by sin; (sin nature

XVII. Young Earth, A False Doctrine

inherited from Adam and Eve) and so death passed upon all men, for that all have sinned:" (Romans 5:12)

A far cry from the claims of the young earth philosophy, which consistently contradicts the Word of God.

"O Timothy, keep that which is committed to thy trust, avoiding profane and vain babblings, and oppositions of science falsely so called:" (1 Timothy 6:20)

Hell Was Prepared For the Devil & His Angels

One might ask, what in the world does this have to do with the young earth advocates claiming, "There was no sin or death before Adam, and projecting a 6,000-year old earth? Let us go to God's Word and see who Hell was prepared for, as described in Matthew 25:41.

"Then shall he say also unto them on the left hand, Depart from me, ye cursed, into everlasting fire, prepared for the devil and his angels."

The "everlasting fire" is the same as the "lake of fire" in Revelation 20:10, "hell fire" in Matthew 5:22 and "hell" in Matthew 23:15, along with several other places.

Hell was first prepared for "the devil and his angels," NOT Adam and Eve. This, again, disintegrates the false theory that there was no sin or death before Adam, as young earth people advocate. If there was no sin before Adam, then WHY wasn't Hell prepared for Adam and Eve, instead of the Devil and his angels?

The Original Creation of the earth in Genesis 1:1 was for the habitation of Lucifer (Satan) and the angels. When Lucifer rebelled against God, this was the first sin that we know about as recorded in God's Word. Ezekiel 28:15 tells us that,

"Thou (Satan) wast perfect in thy ways from the day that thou wast created, till iniquity was found in thee."

Isaiah 12:12-14 describes in detail the sins of Satan and then

XVII. Young Earth, A False Doctrine

describes his ultimate end as recorded in Verse 15.

"Yet thou (Satan) shalt be brought down to Hell, to the sides of the pit."

The Original Creation was then rendered "*without form and void,*" being completely covered with water and darkness as recorded in Genesis 1:2. This was God's judgment upon Satan and the one-third of the angels that followed him (Revelation 12:4). The angels are spirit beings now, known as demons.

The earth remained this way for possibly thousands, millions, or even billions of years before God remodeled it for human habitation in 6 days. The first day of remodeling began in Genesis 1:3. This is what Hell was created for, "*the devil and his angels;*" because they were the first created beings and the first to sin. Your young earth advocates totally deny the Biblical authority of Genesis, Chapter One, in the original text.

In brief summary, the refutation of the false teaching of Mr. Ham, executive director of "Answers in Genesis" and young earth advocates stating "There was no sin or death before Adam."

1. Satan was already at work in the garden.
2. Eve sinned before Adam (Genesis 3:1-6).
3. Romans 5:12 is totally taken out of context and misapplied.
4. Hell was created for the first to sin, by the name of the "Devil and his angels."

The philosophy of the young earth being about 6,000 years old, was dreamed up by a woman false prophet, Ellen G. White. This has now become a flood of false teaching that Satan would love to see cover the world. It is the latest money-making fad!

We are truly in the last days,

"For the time will come when they will not endure SOUND DOCTRINE; but after their own lust (power & money) shall they heap to themselves teachers, having itching ears. (3) For they

XVII. Young Earth, A False Doctrine

shall turn away their ears from the truth, and shall be turned unto fables." (2 Timothy 4:3,4).

Our warning is found in the middle verse of the Bible, Psalm 118:8:

"It is better to trust in the LORD than to put confidence in man."

I contacted the office of one of the young earth advocates concerning his Bible training, and what his beliefs were on certain Biblical doctrines. I asked if he had ever attended any Bible college, or ever took a course in Hebrew or Greek, or ever took any home Bible study courses. I was advised that he had not. I also asked what he believed concerning the Rapture of the church; and, if he were pre-tribulation, post-tribulation, or mid-tribulation. I was advised that he "leans" toward the Rapture and that he is interested in Eschatology; but, does not have time to pursue it, as his time is fully taken up in keeping current with the most recent geological and scientific findings.

It amazes me how this man can deny the Gap Principle, which would allow for the earth (not man) to be millions, or even billions of years old; when he has no Biblical training or even taken a home study Bible course. Not even an introductory course in First Year Hebrew, since Genesis is written in Hebrew.

He refuses to accept the Hebrew text that clearly states that a change of the earth, as created in Verse 1, had taken place as described in Verse 2. Genesis 1:1 states that, "*In the beginning God created the heavens* (Hebrew "shamayim," plural, not singular) *and the earth.*" Isaiah 45:18 tells us in what condition God created the earth.

"For thus saith the LORD that created the heavens; God himself that formed the earth and made it; he hath established it, he created it NOT IN VAIN (Hebrew 'tohow,' meaning "a waste, desolation, wilderness, or without form), he formed it to be inhabited."

The earth was created beautiful for the habitation of Lucifer and the angels. Because of Satan's rebellion and God's judgment

XVII. Young Earth, A False Doctrine

upon the earth, it is found in a state of ruination, desolation, and uninhabitable.

The Hebrew text in Genesis 1:2 makes this perfectly clear. *“And the earth WAS (Hebrew “hayah”) without form and void...”* The English translation of the Hebrew “hayah” should be translated “became.” The reason is, in the Hebrew, when the verb which is “hayah” follows the subject, which is the earth, this indicates a change has been made. Therefore the correct translation of the Hebrew verb “hayah,” showing a change has been made, would be our English “BECAME.” The Original Creation was beautiful; but, at some later time, was found without form and void. Therefore the correct translation of Genesis 1:1,2a would read as follows:

“In the beginning God created the heavens and the earth (i.e. beautiful), But the earth BECAME without form and void (i.e., a wasteland, desolation, and uninhabitable).

The man we are referring to above is one Dr. Walt Brown. Mr. Brown is the author of a book entitled *“In the Beginning.”* In his book, on Page 188, Mr. Brown does make this statement:

“While it is true that the Hebrew word “hayah” can be translated “became,” it is usually translated “was.” He absolutely refuses to accept Biblical authority as given by the Holy Spirit and penned in the original Hebrew manuscripts.

It amazes me how Mr. Brown can deny the Gap Principle, as clearly revealed by the Hebrew text, when he seemingly has no Biblical qualifications to do so. He has attended no Bible college, taken no home Bible study courses, does not teach a Sunday School class, has not even taken first-year, basic Hebrew or Greek. He is not sure about the Rapture, he only “leans that way;” yet, he rejects the first two verses of Genesis, Chapter One, and the disclosure of the time gap between these two verses. Unbelievable! This is what happens when men try to mold the Bible to fit their philosophy of their geological findings.

Since the man has not studied the major doctrines of the

XVII. Young Earth, A False Doctrine

Bible, he would probably fail to recognize the other Gap principles that exist in the Word of God in both the Old and New Testaments. Without some knowledge of the Covenants and Dispensations, it is virtually impossible to rightly divide the Word of Truth (2 Timothy 2:15). Yet this man presents himself as an authority on the first chapter of Genesis. Unbelievable!

I do not for a moment question this man's sincerity. But, being sincere without knowledge of the word of God only leads to disastrous conclusions, no matter *how sincere you are*. Here this man is spending all of his time studying Geology, instead of studying the Word of God. I wonder if he is aware of 2 Timothy 2:15?

"Study to shew thyself approved unto God, a workman that needeth not to be ashamed, rightly dividing the word of truth."

21. The Hermeneutical Gap Principle

Now let us look at a few of the other gap principles that occur in the Word of God. May I point out once again, that studying the Bible systematically and acknowledging the dispensational teachings are of the utmost importance; or one will read right over the Gap periods of time and never recognize them. Now, allow me to draw your attention to a few:

1. Romans 11:25,26. Between verses 25 and 26 there is a gap of seven years. This is the 7 years of Tribulation following the Rapture of the Church.

"For I would not, brethren, that ye should be ignorant of this mystery, lest ye should be wise in your own conceits; that blindness in part is happened to Israel, until the fullness of the Gentiles be come in (the Rapture)." (25)

GAP: 7 years of Tribulation, known as the 70th Week of Daniel.

"And so all Israel shall be saved: as it is written, There shall come out of Sion the Deliverer, and shall turn away the ungodliness from Jacob." (26)

XVII. Young Earth, A False Doctrine

This occurs when Christ returns to establish the Kingdom at the end of the 7 years of tribulation.

2. Revelation 12:5,6. Between Verses 5 and 6 there is a gap consisting of the Church Age, which now has extended over 2,000 years and will consummate at the Rapture. Added to this is the first 3-1/2 years of the 7-Year Tribulation period of time. After 3-1/2 years of peace, the Antichrist breaks his covenant with Israel and seeks to destroy her. Israel's persecution, in part, is spoken of in Matthew 24:15-22. The woman in Revelation, Chapter 12, is none other than the Nation of Israel. (In Jeremiah 3:6-10, Israel is referred to as "she" and "her" as in many other places.)

"And she (Israel) brought forth a man child (Jesus Christ), who was to rule all nations with a rod of iron: and her child (Christ) was caught up (His ascension in Acts 1:11) unto God, and to his throne." (5)

GAP: The Church Age, over 2,000 years plus. Also 3-1/2 of the 7-Year Tribulation period of time.

"And the woman (Israel) fled into the wilderness, where she hath a place prepared of God, that they should feed her there a thousand two hundred and threescore days." (6)

This takes place in the last 3 ½ years of the Tribulation.

3. John 5:29. This verse gives a general statement concerning the Resurrection of Life and the Resurrection of Damnation. Between these two Resurrections there is a gap period of time. This gap is 1,000 years long, in which Christ will reign on this earth as King of Kings and Lord of Lords. I will quote Verse 28 and the first half of Verse 29, as the Resurrection of life is composed of four separate events, which include all the saved.

"Marvel not at this: for the hour (i.e., time) is coming; in the which all that are in the graves shall hear his voice." (28) And shall come forth; they that have done good, unto the Resurrection of life...(Verse 29a).

XVII. Young Earth, A False Doctrine

The Resurrection of Life is composed of four parts as follows:

- a. Christ's Resurrection and being the First Fruits (1 Corinthians 15:20-23) of them that sleep, along with those resurrected in Matthew 27:52,53.
- b. Those at the Rapture. *"The dead in Christ shall rise first."* (1 Thessalonians 4:13-17 and 1 Corinthians 15:50-54).
- c. The Two Witnesses in the Tribulation Period. (Revelation 11:3,7-12).
- d. All the Old Testament saints, along with those in Revelation 20:4 who were beheaded in the Tribulation for refusing to worship the Antichrist; but here resurrected to live and reign with Christ for 1,000 years.

The First Resurrection is composed of all the saved.

Now notice in Revelation 20:5,6.

"But the rest of the dead (i.e., the lost) lived not again until the thousand years (Christ's Kingdom Reign) were finished. This is the first Resurrection." (5) Blessed and holy is he that hath part in the first resurrection: on such the second death hath no power, but they shall be priests of God and of Christ, and shall reign with him a thousand years." (6)

GAP: of the 1,000 year reign of Christ before the "Resurrection of damnation" spoken of in the last half of the verse in John 5:29b.

"And they that have done evil, unto the Resurrection of damnation." (29b)

This Resurrection consists of only those who are lost. This is the Great White Throne Judgment where the lost are brought up out of Hell (Greek "Hades") and cast into the lake of fire for all eternity. (Revelation 20:11-15).

4. Isaiah 9:6,7. Between these two verses there is the GAP of the Church Age and the 7-Year Tribulation.

"For unto us a child is born (Christ), unto us a son is given.." (6)

XVII. Young Earth, A False Doctrine

This is speaking of the BIRTH of Christ.

GAP: Church Age, 2,000-plus years, also included, the 7-Year Tribulation Period, and then Christ comes back to establish His kingdom reign spoken of in Verse 7.

"Of the increase of his government and peace there shall be no end, upon the throne of David, and upon HIS KINGDOM to order it, and to establish it with judgment and with justice from henceforth ever for ever." (7)

5. Malachi 3:1,2. Between Verses 1 and 2 we have a gap period of time. The gap is composed of the Church Age plus the 7-Year Tribulation Period.

"Behold, I will send my messenger (i.e. John the Baptist) and he shall prepare the way before me:... (1)

GAP: The Church Age 2,000-plus years, also the 7-Year Tribulation Period of time.

"But who may abide the day of his coming? and who shall stand when he appeareth? for he is like the refiner's fire, and fuller's soap." (2)

This is when Christ returns to judge the nations at the end of the Tribulation Period, just prior to establishing the Kingdom. Matthew 25:31-41 speaks of the same event, as well as many other Scriptures. So, between Verse 1, which is speaking of John the Baptist, and Verse 2, speaking of Christ's return to earth to judge the nations and set up the Kingdom; there is a GAP of 2,000-plus years, besides the 7-Year Tribulation Period.

I have only projected five examples of the gap principle in order to show that in studying God's Word, it must be rightly divided (2 Timothy 2:15). Young earth advocates absolutely refuse to believe the first mention of a Gap Principle as given in Genesis, Chapter One, between Verses One and Two. I get a little sick of hearing from some of these young earth advocates, such as Ken Ham, saying, "We must get back to Biblical authority."

Statements similar to this are only a smoke-screen to make

XVII. Young Earth, A False Doctrine

you believe that you are denying God's Word and its authority if you don't believe their philosophy, i.e., that the earth is only about 6,000 years old. This is "brain washing" philosophy at its best. (or worst?) I wonder if these young earth advocates even recognize the gap of the Church Age in the Old Testament.

The Old Testament prophets knew nothing of the Dispensation of the Church Age. You can search the Old Testament through from Genesis to Malachi and you will not find one reference to the Church Age. This dispensation of time we are now in was a mystery. A mystery in the New Testament is a truth which has never previously been revealed; but, now is made known for the first time. The Apostle Paul, who had penned fourteen of the twenty-seven books of the New Testament by the inspiration of the Holy Spirit, would be the one to expound on these truths; which had previously not been known to the prophets. Read Ephesians 3:1-10.

We shall see, later on, that the theology of many of these young earth advocates is corrupt. Since they refuse to accept the Gap Principle in Genesis 1:1-3 as set forth in the original Hebrew, then how could these same men recognize this same Gap Principle which is prolific throughout the Old Testament?

Maybe I should remind our readers again that it was a Seventh-Day Adventist, a so-called prophet named Ellen G. White, which introduced the young earth philosophy. A man by the name of George McCready Price, who was an amateur geologist, followed her philosophy; thus attributing most fossil-bearing rock formations to the geological disruptions of the Biblical flood. Only a hand-full followed his philosophy before his death in 1963.

Two years prior to Price's death, a book entitled "The Genesis Flood" came out in 1961. One John C. Whitcomb, Jr. and Henry J. Morris, a hydraulic engineer, co-authored the book. They borrowed and incorporated the same pseudo-philosophy from one Ellen G. White. "The Genesis Flood" which was very

XVII. Young Earth, A False Doctrine

influential in promoting the young earth philosophy and, in turn, led to the formation of the Creation Research Society in 1963. This society is dedicated to promoting their philosophy and theory of a young earth of only about 6,000 years old.

22. What About the Length of Days In Genesis, Chapter One

Question: Is a Day a Geological Age; Or, Is a Day a 24-Hour Period, the Same as We Have Today?

Answer: Some of the young earth advocates, who do not believe the Biblical record of a period of time between the Original Creation in Genesis 1:1, and the renovation from Vs. 2-20, falsely assert that those who hold to the Biblical authority of the Gap Principle also endorse a day as a geological period of time. They set up the “straw man” of this false accusation and then proceed to “knock it down.” This is a FALSE accusation and an outright lie perpetrated by some who hold to the young earth philosophy.

The following will substantiate this.

Allow me to make it perfectly clear that the great fundamental Bible teachers and scholars that I have known personally, or others by their writings, endorse two fundamental facts concerning Genesis, Chapter One. They are the Gap Principle and the "days" of creation as 24 hours long, NOT a geological age. This is, therefore, based on Biblical authority and not the philosophy of the young earth advocates and their lies!

The following is proof of a twenty-four (24) hour day, in lieu of a geological age time frame.

The main reason the 24-hour day in Genesis has been questioned is to fit in the evolutionist's theory of evolution; therefore allowing millions of years for man and animals to evolve. I will list just a few of the many reasons why a day is 24 hours, and not a geological age of 500,000 years as many so-

XVII. Young Earth, A False Doctrine

called scientists speculate.

1. Proof by Biblical Context:

In Genesis 1:5,8,13,19,23,31 the Lord says "and the evening and the morning" were the first day, second day, third day, and etc. He did not say the evening and the morning were a geological age. I think God knows the difference between a geological age of 500,000 years and 24 hours, don't you? What better context of definition could one ask of God than, a day consists of light and darkness divided by evening and morning, just as we have today.

Some say a day and night were longer then, than now. This is easily disproved by the Psalmist. In Psalm 136:5, 8, 9, we read,

"To him that by wisdom made the heavens." (5) The sun to rule by day (V.8)...the moon and stars to rule by night..." (9)

The sun was shining in the daytime while the Psalmist was living, just as it was when man was created, and just as it is now. It is the same with the moon and stars at night. Nothing has changed in the length of day since the creation of man.

2. Proof as Spoken by Christ.

In John 11:9, about 2,000 years ago, Christ made it clear that a day is composed of 24 hours, just as it has been from God's creation of man.

"Jesus answered, are there not twelve hours in the day..."

Do not 12 hours in the daytime and 12 hours in the night time make a 24 hour day? I believe it does.

3. Proof by the Flood.

Approximately 1600 years after the creation of man, the earth was destroyed by a universal flood. At this time God used years, months, days and numbers, just as we have today, to tell us when the rains of the flood began.

"In the six hundredth year of Noah's life, in the second month, seventeenth day of the month, the same day all the fountains of

XVII. Young Earth, A False Doctrine

the great deep were broken up, and the windows of heaven were opened.” (Genesis 7:11)

“And the rain was upon the earth forty days (12 hours) and forty nights (12 hours).” Therefore forty, 24 hour days just as we have today.

4. Proof by Botany.

(a). In Genesis 1, God said He created man on the sixth day. If a day is as the evolutionists claim, you would have 250,000 years of total darkness and 250,000 years of light. Can you explain how all the animals, plants, and human life could survive for 250,000 years in total darkness? There would be no fruits, vegetables, trees, etc., as nothing would be able to grow without sunlight.

(b). Plants and animals have a balance in nature, and both are essential to each other for the survival of both. You see, animals take in Oxygen and give off Carbon Dioxide; while plants take in Carbon Dioxide and give off Oxygen. One cannot survive without the other producing what it needs to survive.

Notice carefully Genesis 1:11,12. God “brought forth” all vegetation on the third day. In Genesis 1:21-23, God created on the fifth day all of the sea creatures and winged fowl. In Vss. 24,25, God “made” the animals that require Oxygen produced by the vegetation. Plants need Carbon Dioxide to live, which is given off by the animals. Since many of the evolutionists claim a day is 500,000 years, they disprove their own claim, as plants and animals could not survive.

Agricultural Science proves that vegetables, trees, etc., could not survive even for a short period of time, let alone 500,000 years without animals. The evolutionist refuses to even believe true scientific findings; yet, they want you and I to believe their false theories. How preposterous!

5. Proof by Contradiction.

Any evolutionist, who believes in the geological age theory

XVII. Young Earth, A False Doctrine

of Creation; presents himself as God, and denies the true God of Creation. Here is the proof. In Genesis 1:26-31, Adam and Eve were created on the sixth day. God then rested on the seventh day. After the seventh day, we have the record of Adam and Eve being in the Garden of Eden. If a day is a geological age of 500,000 years, then Adam would have had to be over 500,000 years old when he died. BUT God says in Genesis 5:5 that the day-age theory is a LIE because...

"...all the days that Adam lived were nine hundred and thirty years (930 yrs.)."

6. Proof by Interpretation.

Whenever a number appears before the word "day" in the Bible, it is always, without exception, a 24 hour day. For a start, look up Numbers 7:12,18, 24, 30, 36, 42, 48, 54, 60, 66, 72, and 78. Those who claim the day-age theory deny the God of Creation and true Agricultural Science. They are, in a very subtle way, trying to magnetize anyone they can toward their evolutionary beliefs. Much more could be said—I hope this will suffice.

7. Proof By Reasoning.

The evening and morning is in exact conformity with the words of Moses and Christ. In Leviticus 24:3, Moses stated the Lord's instructions concerning the lamb's sacrifice,

"The one lamb shalt thou offer in the morning; and the other lamb thou shalt offer in the even." (Leviticus 24:3).

Could it be any clearer than spoken by Christ, himself, in John 11:9, "Jesus answered, are there not twelve hours in the day..." If I am not mistaken, twelve hours in the daylight and twelve hours in the night equal a twenty-four hour day. Just as Genesis One says that the evening and the morning were the first day in Verses 5,8,13,19,23, and 31

If God is what He claims to be, omniscient and omnipotent, then He is wise enough to state clearly the facts of His creation

XVII. Young Earth, A False Doctrine

and powerful enough to accomplish it. Those who claim the Day-Age Theory are, in a very subtle way, trying to magnetize people toward their evolutionary beliefs.

We pray that Christians will take these facts, which leave no question that a day in Genesis One is a twenty-four hour day, and be ready to give an answer to those who try to twist the Bible to their own liking. Especially those who try to wedge a space in God's Word in which to fit their theory of evolution.

Just as God gave the simple record of creation...He also left a record concerning His Son, Jesus Christ.

"And this is the record that God hath given to us eternal life and this life is in his Son." (1 John 5:11)

Yes, God sent His Son to pay for the sins of every individual and now He promises to each one that will accept Christ as their personal Savior...eternal life.

The record in Genesis One tells us how we got here. The record in 1 John Five tells us where we are going. Where are you going? It is either Heaven or Hell. Will you accept Christ today as the One who loved you and paid for your sins on Calvary; so you could live with Him in Heaven for all eternity?

"For God so loved the world (you and I) that he gave his only begotten Son, that whosoever BELIEVETH IN HIM should not perish, but have everlasting life." (John 3:16)

XVIII. Other Books By Author

THE TRUTH ABOUT EVOLUTION OR; DON'T LET SATAN MAKE A MONKEY OUT OF YOU! This book defends Creation vs. Evolution and refutes the False Philosophy and Theory of a Young Earth. Perfect Bound, 248 pages, index to pages outlines all topics covered, indicating location of diagrams and illustrations. The suggested donation is \$8.00.

MARTIN LUTHER, MASTER OF DECEIT - Perfect Bound 5-1/2 x 8-1/2, 277 pages with Scripture Index, Available for a donation of \$8.00. Luther did not believe God's Ten Commandments and eliminated the Second one in his Catechisms. Luther absolutely did not believe that salvation was by faith in Christ alone. Each verse Luther uses is examined in detail in this book. You will cringe at what Luther has to say about the Jewish people.

A BIBLICAL EXAMINATION OF HELL - This book has 7 color diagrams, coded to the text. Perfect Bound 88 pages, 8-1/2" x 11." The suggested donation is \$9.00 requests. A Bible study companion, the charts and comments help clarify much misunderstanding concerning the subject of Hell.

FACE TO FACE WITH TONGUES - Perfect Bound, 5-1/2 x 8-1/2, 123 pages, the suggested donation is \$7.00. A verse by verse examination of all the Scriptures concerning the "speaking in tongues," leading to the conclusion this is not for the Church today. Tongues ceased with the completion of God's word, in about 96 A.D.

A BIBLICAL EXAMINATION OF BAPTISM - Perfect Bound (Paper-back) 5-1/2 x 8-1/2, 88 Pages, suggested donation is \$7.00. Covers all the Scriptures about baptism in the New Testament with thorough exegesis as to what baptism really is and what it isn't! This book scripturally refutes infant baptism. Explains the different baptisms taught in the Bible and their purpose

XVIII. Other Books By Author

SALVATION & THE PUBLIC INVITATION - Perfect Bound (Paper-back), 5-1/2" x 8-1/2", 128 Pages, the suggested donation is \$7.00. This book challenges a long held tradition of many churches. Do you have to walk to the front of a church to be saved; or, is it just another tradition that has crept into the church. This book will challenge you to cast aside preconceived ideas and search the Scripture for yourself.

NOT CHOSEN TO SALVATION - Perfect Bound (Paper-back) 5-1/2 x 8-1/2, 196 Pages, suggested donation is \$8.00. This book is a refutation of David Nettleton's book, Chosen To Salvation. It covers all the Scriptures relating to the false doctrine of predestination for salvation, providing the reader with tools for witnessing. This evil doctrine and is nothing less than an attack on the Grace of God. Scripture Index in the back.

THREE IMPORTANT QUESTIONS - Perfect Bound (Paper-back) 5-1/2 x 8-1/2, 98 pages. The suggested donation is \$7.00.

Question One: When Did Christ Rise From The Grave?
This chapter has two diagrams, refuting the fallacies of Good Friday and Easter Sunday.

Question Two: Is God Unfair To The Heathen?

Question Three: Are We To Worship On Saturday?

How to Order Books

The Suggested Donations Are For Shipping and Cost Only!
Please send your check or money order and your book list to:

Heritage Baptist Bible Church

Attn: Internet Book Order

P.O. Box 573

Walnut Grove, MN 56180

XIX. About The Author

Dr. Younce has been in the ministry 40 years, having been ordained in 1970. He is a graduate of Florida Bible College and holds a Doctorate in Theology. He has pastored churches in Ohio, Indiana, Florida, and Minnesota. He is the founding pastor of Heritage Bible Church in Ohio and Heritage Baptist Bible Church in Walnut Grove, Minnesota. He and his wife, Marge, have made Walnut Grove their home since 1991.

Dr. Younce's ministry has always been motivated by a caring evangelistic outreach. Thirty-six years of radio and recently television, bear this out. Teaching is another characteristic of Dr. Younce's ministry. This is evidenced by the many Bible Institute courses he has taught over the years.

Dr. Younce's style of writing is Bible-centered, direct, and inspiring. He "pulls no punches" to tickle the ears. He believes now, more than ever, people need to know what the Bible says...and they need not to be deceived by the "vain traditions of men!"